

THIS DOCUMENT IS THE PROPERTY OF KEYSTONE ELECTRONICS CORP. AND SHALL NOT BE REPRODUCED, DISTRIBUTED OR USED AS A BASIS FOR MANUFACTURE WITHOUT PRIOR WRITTEN PERMISSION FROM KEYSTONE ELECTRONICS CORP.

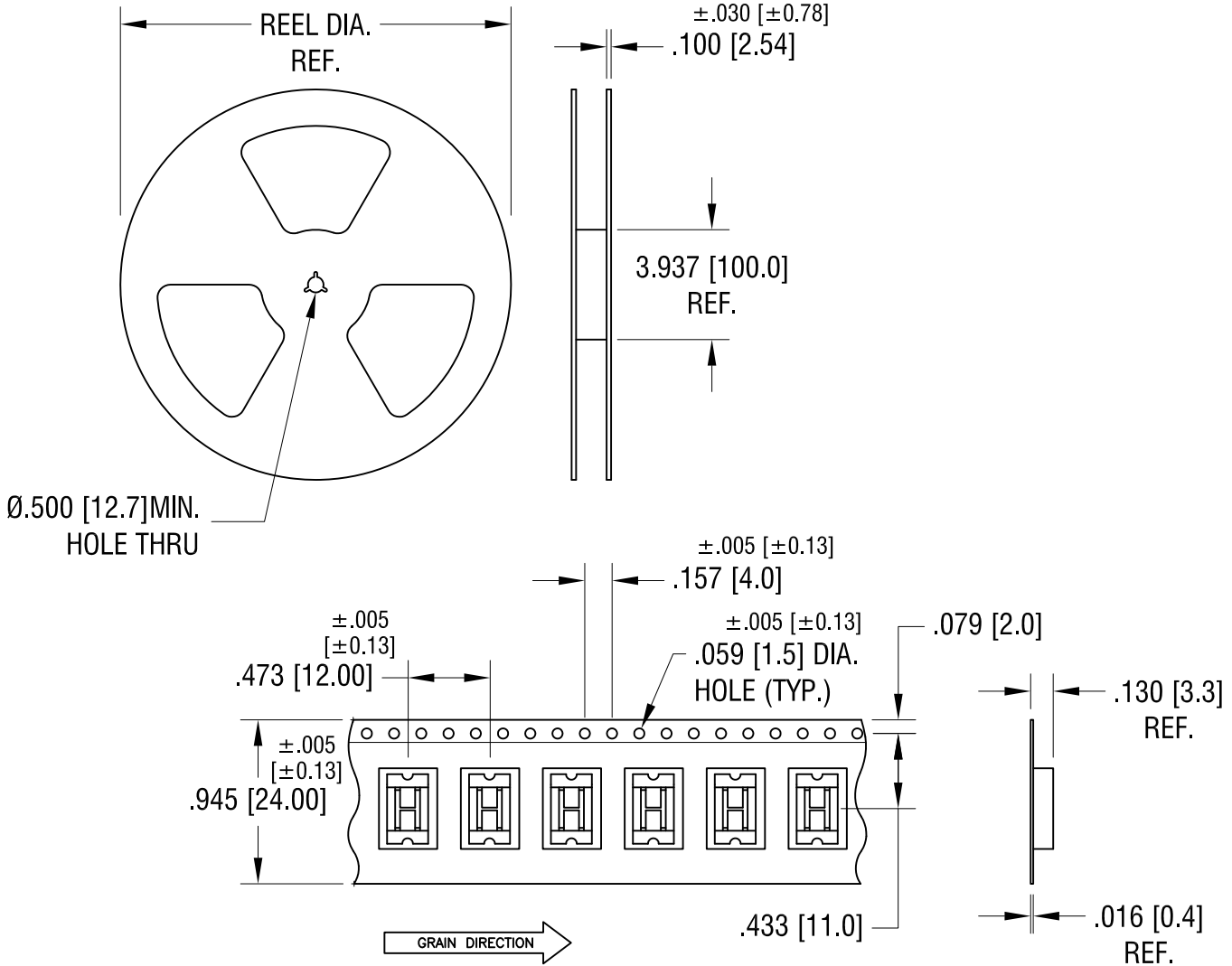

NOTES:

TAPE AND REEL SPECIFICATIONS:

1. TAPE:

MAT'L - ALL CONDUCTIVE POLYSTYRENE CARRIER
ANSI/EIA-481 STANDARD

2. REEL:

13.0 [330.2] DIA. 1500 PIECES OF
PART NO. 3583 PER REEL

3. KAPTON TAPE TO BE APPLIED TO TOP

SURFACE OF FUSE CLIP FOR VACUUM PICK AND PLACE

KEYSTONE ELECTRONICS CORP.			
www.keyelco.com • NEW HYDE PARK, NY 11040 • Tel (516) 328-7500			
PART NAME			
SM MINI-AUTO BLADE CLIP ON TAPE			
MATERIAL			
AS NOTED			
FINISH		DRN BY	DATE
AS NOTED		NT	2.13.18
		APP'D	SCALE
		RH	X
TOLERANCES	INCH	[MM]	CODE
DECIMAL	± 0.15	[± 0.38]	C
ANGULAR	± 1°		
UNLESS OTHERWISE SPECIFIED			DRW NO.
			3583KTR

DATE	DESCRIPTION	REV.

THIS DOCUMENT IS THE PROPERTY OF
KEYSTONE ELECTRONICS CORP. AND
SHALL NOT BE REPRODUCED, DISTRIBUTED
OR USED AS A BASIS FOR MANUFACTURE
WITHOUT PRIOR WRITTEN PERMISSION
FROM KEYSTONE ELECTRONICS CORP.

ACTUAL SIZE

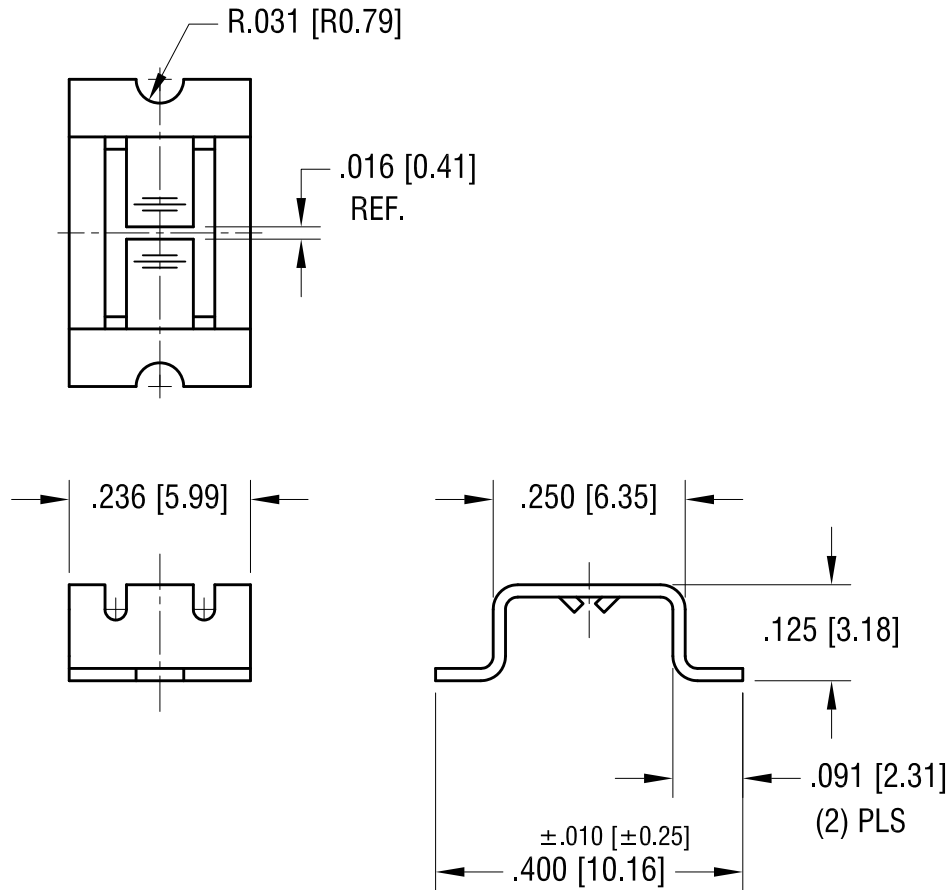

KEYSTONE ELECTRONICS CORP.

www.keyelco.com • ASTORIA, N.Y. 11105-2017 • Tel (718) 956-8900

PART NAME

SM MINI-AUTO BLADE FUSE CLIP

MATERIAL

.016 [0.40] TH'K BRASS

FINISH

MATTE TIN PLATE

DRN BY

NT

DATE

4.06.17

APP'D

LN

SCALE

4X

TOLERANCES

INCH [MM]

CODE

DWG NO.

DECIMAL ± .005 [± 0.13]

C

ANGULAR ± 1°
UNLESS OTHERWISE SPECIFIED

3583

DATE	DESCRIPTION	REV.