



SURFACE MOUNT

Power Splitter/Combiner

SP-2P1+

2 Way-0° 50Ω 1350 to 2250 MHz

FEATURES

- Wide bandwidth
- Low insertion loss, 0.5 dB typ.
- Good isolation, 20 dB typ.
- Excellent output VSWR, 1.2:1 typ.
- Excellent power handling, 1.5W
- Small size
- Aqueous washable



Generic photo used for illustration purposes only

CASE STYLE: CA531

+RoHS Compliant

The +Suffix identifies RoHS Compliance. See our website for methodologies and qualifications

APPLICATIONS

- PCS/DCS
- Communication systems
- Mobile
- PDC
- GPS
- GSM

ELECTRICAL SPECIFICATIONS AT 25°C

Parameter	Frequency (MHz)	Electrical Specifications			Units
		Min.	Typ.	Max.	
Frequency Range		1350		2250	MHz
Insertion Loss (above 3.0 dB)	1350-2250	—	0.5	1.1	dB
Isolation	1350-2250	9	20	—	dB
Amplitude Unbalance	1350-2250	—	—	0.2	dB
Phase Unbalance	1350-2250	—	—	4	deg.
VSWR (Port S)	1350-2250	—	1.3	—	:1
VSWR (Port 1)	1350-2250	—	1.2	—	:1
VSWR (Port 2)	1350-2250	—	1.2	—	:1

MAXIMUM RATINGS

Parameter	Ratings
Operating Temperature	-40 °C to +85 °C
Storage Temperature	-65 °C to +150 °C
Input Power (as a splitter)	1.5 W max.
Internal Dissipation	0.75W max.

Permanent damage may occur if any of these limits are exceeded.

ELECTRICAL SCHEMATIC





SURFACE MOUNT

Power Splitter/Combiner

SP-2P1+

2 Way-0° 50Ω 1350 to 2250 MHz

PIN CONNECTIONS

SUM PORT	5
PORT 1	1
PORT 2	3
GROUND	2,4,6

PRODUCT MARKING: N/A

DEMOBOARD MCL P/N: TB-374
SUGGESTED PCB LAYOUT (PL-232)

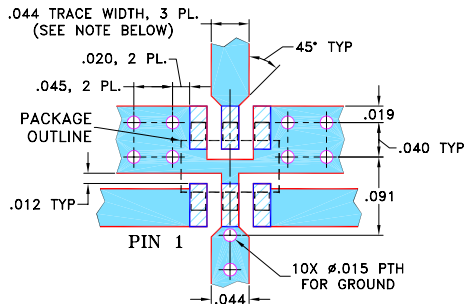

- NOTES: 1. TRACE WIDTH IS SHOWN FOR ROGERS RO4350B WITH DIELECTRIC THICKNESS .020" ± .0015"; COPPER: 1/2 OZ. EACH SIDE. FOR OTHER MATERIALS TRACE WIDTH MAY NEED TO BE MODIFIED.
2. BOTTOM SIDE OF THE PCB IS CONTINUOUS GROUND PLANE.

- DENOTES PCB COPPER LAYOUT WITH SMOBC (SOLDER MASK OVER BARE COPPER)
- DENOTES COPPER LAND PATTERN FREE OF SOLDER MASK

OUTLINE DRAWING

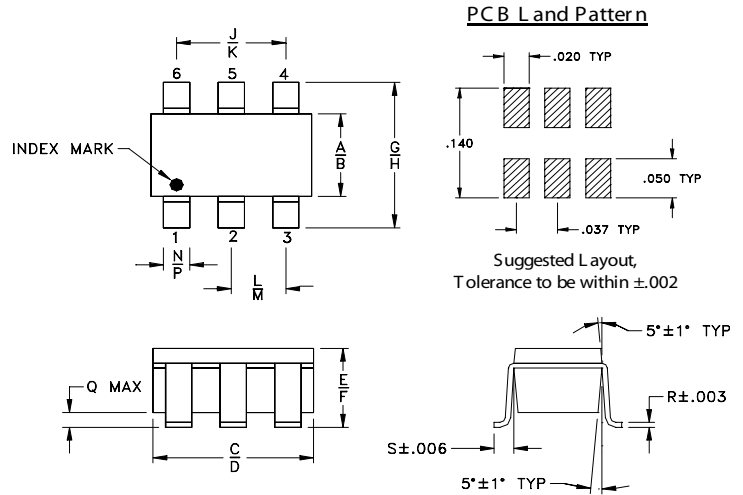

OUTLINE DIMENSIONS (Inch/mm)

A	B	C	D	E	F	G	H	J
.052	.067	.106	.122	.035	.064	.087	.118	.067
1.32	1.70	2.69	3.10	0.89	1.63	2.21	3.00	1.70
K	L	M	N	P	Q	R	S	wt
.083	.033	.042	.012	.020	.012	.006	.018	grams
2.11	0.84	1.07	0.30	0.51	0.30	0.15	0.46	0.020

TAPE & REEL INFORMATION: F31



SURFACE MOUNT

Power Splitter/Combiner

SP-2P1+

2 Way-0° 50Ω 1350 to 2250 MHz

TYPICAL PERFORMANCE DATA AND CHARTS

Frequency (MHz)	Total Loss ¹ (dB)		Amplitude Unbalance (dB)	Isolation (dB)	Phase Unbalance (deg.)	VSWR (:1)		
	S-1	S-2				S	1	2
1350.00	3.45	3.42	0.03	11.34	0.43	1.40	1.28	1.26
1400.00	3.44	3.41	0.03	12.25	0.42	1.36	1.24	1.22
1500.00	3.42	3.40	0.02	14.49	0.42	1.30	1.16	1.14
1600.00	3.41	3.39	0.02	17.51	0.42	1.24	1.08	1.06
1700.00	3.41	3.39	0.01	22.19	0.43	1.21	1.00	1.01
1710.00	3.41	3.39	0.01	22.82	0.43	1.21	1.00	1.02
1770.00	3.41	3.40	0.01	27.94	0.44	1.20	1.05	1.06
1830.00	3.43	3.42	0.01	36.58	0.47	1.21	1.10	1.11
1860.00	3.43	3.43	0.01	34.67	0.48	1.22	1.12	1.13
1920.00	3.46	3.45	0.00	26.70	0.50	1.26	1.17	1.18
1950.00	3.47	3.47	0.00	24.20	0.52	1.28	1.19	1.20
2000.00	3.50	3.50	0.00	21.14	0.55	1.33	1.23	1.25
2125.00	3.61	3.61	0.01	16.35	0.65	1.49	1.34	1.35
2225.00	3.73	3.75	0.01	13.84	0.75	1.66	1.42	1.42
2250.00	3.77	3.79	0.01	13.32	0.74	1.71	1.44	1.44

1. Total Loss = Insertion Loss + 3dB splitter loss.

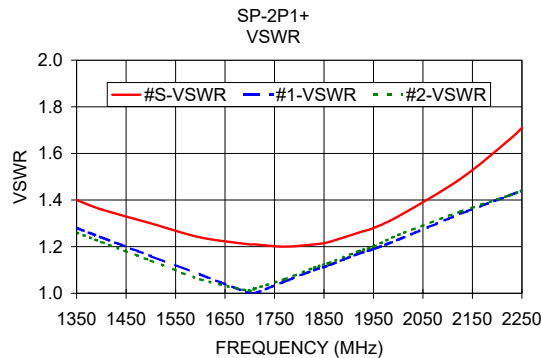
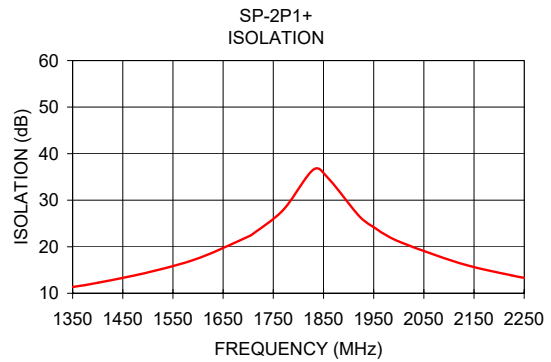
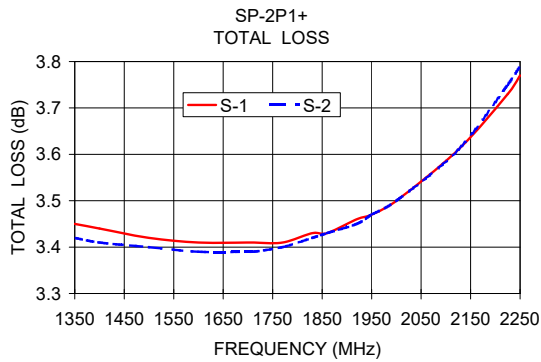

ESD Rating

Human Body Model (HBM): Class 1A (250 v to <500 v) in accordance with ANSI/ESD STM 5.1 - 2001
Machine Model (MM): Class M1 (< 100 v) in accordance with ANSI/ESD STM 5.2 - 1999 (pass 50V)

NOTES

- A. Performance and quality attributes and conditions not expressly stated in this specification document are intended to be excluded and do not form a part of this specification document.
- B. Electrical specifications and performance data contained in this specification document are based on Mini-Circuit's applicable established test performance criteria and measurement instructions.
- C. The parts covered by this specification document are subject to Mini-Circuits standard limited warranty and terms and conditions (collectively, "Standard Terms"); Purchasers of this part are entitled to the rights and benefits contained therein. For a full statement of the standard terms and the exclusive rights and remedies thereunder, please visit Mini-Circuits' website at www.minicircuits.com/terms/viewterm.html

