

PART NUMBER	REVISION	DESCRIPTION	FEED TYPE
2266118-1	H	FINE CRIMP HEIGHT ADJUST	MECHANICAL
2266118-2	H	FINE CRIMP HEIGHT ADJUST	PNEUMATIC
5-2266118-1	H	SEAL STRIPPER CRIMPER TERMINATING UNIT	MECHANICAL
5-2266118-2	H	SEAL STRIPPER CRIMPER TERMINATING UNIT	PNEUMATIC
7-2266118-1	H	MECHANICAL AND CRIMP TOOLING KIT	MECHANICAL
7-2266118-2	H	PNEUMATIC AND CRIMP TOOLING KIT	PNEUMATIC
7-2266118-7	C	CRIMP TOOLING KIT	-
7-2266118-8	C	APPLICATOR CONVERSION KIT	-

ATLANTIC VERSION TERMINATOR INTERFACE ADAPTER

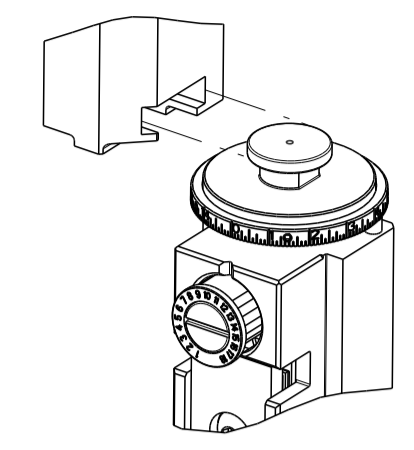

APPLICATOR DATA

CRIMP	SIZE	TYPE
WIRE	1.75 mm [.069]	F
INSUL	2.03 mm [.080]	O

APPLICATOR INSTRUCTIONS  
408-35042

APPLICATOR CONVERSION KITS

PART NUMBER	INSULATION DIAMETER RANGE
7-2266116-8	Ø2.74-3.18mm [.108-.125]
7-2266117-8	Ø2.31-2.72mm [.091-.107]
7-2266118-8	Ø1.91-2.29mm [.075-.090]
7-2266119-8	Ø1.60-2.16mm [.063-.085]
7-2266120-8	Ø1.27-1.57mm [.050-.062]

TERMINAL DATA: DEUTSCH TERMINAL DEUTSCH CRIMP SPECIFICATION

TERMINAL NAME: STAMPED CONTACT PIN SIZE 20

WIRE STRIP LENGTH	INSULATION DIAMETER RANGE
3.81-5.09 mm [.150-.200 IN]	Ø1.91-2.29 mm [.075-.090 IN]

TERMINAL APPLICATION SPECIFICATION 114-151003

TERMINALS APPLIED

TE TERMINAL	DEUTSCH TERMINAL	TE TERMINAL	DEUTSCH TERMINAL
1572032-1	1060-20-0122	1572032-2	1060-20-0144
1572032-7	1060-20-0177		

TERMINAL DATA: DEUTSCH TERMINAL DEUTSCH CRIMP SPECIFICATION

TERMINAL NAME: STAMPED CONTACT SOCKET SIZE 20

WIRE STRIP LENGTH	INSULATION DIAMETER RANGE
3.81-5.09 mm [.150-.200 IN]	Ø1.91-2.29 mm [.075-.090 IN]

TERMINAL APPLICATION SPECIFICATION 114-151003

TERMINALS APPLIED

TE TERMINAL	DEUTSCH TERMINAL	TE TERMINAL	DEUTSCH TERMINAL
286680-1	1062-20-0122	286680-2	1062-20-0144
286680-9	1062-20-0177	286680-5	1062-20-0322
286680-6	1062-20-0344	1-286680-0	1062-20-0377

WIRE SIZE	CRIMP HEIGHT mm [INCH]	CRIMP HEIGHT REFERENCE SETTING
1.50mm2	1.47+0.03/-0.05 [.058+.001/- .002]	3.4
16 AWG	1.27+0.03/-0.05 [.050+.001/- .002]	5.4
1.00mm2	1.27+0.03/-0.05 [.050+.001/- .002]	5.4
18 AWG	1.24+0.03/-0.05 [.049+.001/- .002]	5.7
0.75mm2	1.22+0.03/-0.05 [.048+.001/- .002]	5.9
0.60mm2	1.07+0.03/-0.05 [.042+.001/- .002]	7.4
20 AWG	0.99+0.03/-0.05 [.039+.001/- .002]	8.2
0.50mm2	0.97+0.03/-0.05 [.038+.001/- .002]	8.4
22 AWG	0.94+0.03/-0.05 [.037+.001/- .002]	8.7
0.35mm2	0.94+0.03/-0.05 [.037+.001/- .002]	8.7

- RECOMMENDED SPARE PARTS
- REFER TO SUPPLIED INSTRUCTION SHEET FOR CLEANING, LUBRICATION & STORAGE OF APPLICATOR.
- APPLY PART NUMBER 1-23419-5 LOCTITE TO THREADS OF ITEM 180. APPLY PART NUMBER 2-23419-6 LOCTITE TO THREADS OF ITEM 242.
- CRIMP HEIGHT REFERENCE SETTING WAS THE SETTING USED WHEN THE APPLICATOR WAS QUALIFIED AT THE FACTORY. ADJUSTMENT MAY BE NECESSARY WHEN RUNNING APPLICATOR IN THE FIELD.
- SEE APPROPRIATE APPLICATOR LOG SHEETS FOR APPLIED TERMINALS, WIRE RANGE AND MEMORY CHIP.
- TERMINAL LUBRICANT IS RECOMMENDED.
7. UNLESS SPECIFIED OTHERWISE TORQUE VALUES SHALL BE USED PER DOCUMENT, 101-35000.

\*WARNING  
 ON INSTALLATION, SET WIRE DISC TO CRIMP HEIGHT REFERENCE SETTING FOR LARGEST WIRE SIZE. CRIMP HEIGHT REFERENCE SETTINGS GREATER THAN THE VALUE SHOWN MAY CAUSE DAMAGE TO THE CRIMP TOOLING, REFER TO THE INSTRUCTION SHEET FOR PROPER SETUP AND ADJUSTMENTS.

ATLANTIC VERSION  
 Shown on sheets 1 of 4 & 2 of 4  
 (Pacific version shown on sheets 3 of 4 & 4 of 4)

LOC	DIST	REV	DATE	BY	CHK
A	66	E1	25SEP2019	FJ	TE
		F	30JUL2020	FZ	RK
		G	16SEP2020	FZ	RK
		H	05MAY2022	FZ	GB

REV	DATE	BY	CHK	DESCRIPTION	ITEM NO	
-	-	-	-	1803515-3	RAM ASSEMBLY, SF ATLANTIC	293
-	-	-	-	2-1803583-1	APPLICATOR BASIC ASSEMBLY, SF	292
-	-	2	2	2168083-1	SCR, SKT HD CAP, RoHS, M3 X 8.0	269
-	-	1	1	2-1633782-0	FENCE	267
-	-	1	1	2119641-1	FEED CAM, AIR FEED	248
-	-	1	1	2119082-9	CAM, SNAIL, INSULATION ADJUSTMENT	244
-	-	1	1	2079764-1	WASHER, WAVE SPRING, CREST-TO-CREST	243
-	-	1	1	2119083-1	RETAINER, INSULATION DIAL	242
-	-	1	1	7-18023-7	SCR, SKT HD CAP M3 X 4.0	241
-	-	1	1	2119580-1	MECHANICAL FEED ASSEMBLY	239
-	-	1	1	2844940-1	AIR FEED MODULE	238
-	-	1	1	4-1722335-3	STRIPPER, SIDE FEED	182
-	-	1	1	1-5018030-0	NUT, HEX, REG, RoHS, M3.5	181
-	-	1	1	1-1752354-8	STANDOFF,HOLD-DOWN	180
-	-	1	1	993111-1	PIN, SLOTTED SPRING 3.0 X 20.0	177
-	-	1	1	5-22280-0	SPRING, COMPRESSION	176
-	-	1	1	1752353-3	GUIDE PIN,HOLDDOWN	175
-	-	1	1	1901680-2	GUIDE PIN,HOLDDOWN	174
-	-	REF	REF	994970-2	COUNTER, MAGNETIC	164
-	-	1	1	1-18028-2	WASHER, FLAT, REG M4	119
-	-	1	1	2119955-1	ASSY, LUBRICATOR, SIDE FEED	113
-	-	1	1	2844908-1	SCREW, LOCKING	99
-	-	1	1	2844907-1	POST, LOCKING	98
-	-	1	1	455888-7	SPACER, CRIMPER	82
1	-	-	-	2266118	PRINT, APPLICATOR LOG SHEET	72
-	-	1	1	1803607-3	DOCUMENTATION PACKAGE	71
-	-	1	1	2119791-9	DEPRESSOR, WIRE	70
-	-	1	1	2119740-1	TAG, IDENTIFICATION	67
-	-	2	2	2168078-1	SCREW, DRIVE, RH, RoHS, 2 x .188	66
-	-	1	1	2168083-2	SCR, SKT HD CAP, RoHS, M4 X 8.0	60
-	-	1	1	5-18022-5	SCR, HEX HD CAP, M4 X 6.0	59
-	-	1	1	1338685-1	PAWL, FEED	56
-	-	4	4	2168083-3	SCR, SKT HD CAP, RoHS, M4 X 12.0	54
-	-	2	2	1-2168083-0	SCR, SKT HD CAP, RoHS, M4 X 10	53
-	-	1	1	1803382-6	HOLD DOWN, SPRING LOADED	50
-	-	1	2	18023-9	SCR, SKT HD CAP M4 X 6.0	49
-	-	1	1	2119652-1	FEED CAM, PRE FEED	48
-	-	1	1	2119653-1	FEED CAM, POST FEED	47
-	-	1	1	1803583-9	APPLICATOR BASIC ASSEMBLY, SF	46
-	-	1	1	1803515-1	RAM ASSEMBLY, SF ATLANTIC	44
-	-	1	1	1803602-1	SCR, BHSC, RoHS (M8 X 25)	41
-	-	1	1	2-1752356-0	SUPPORT, TERMINAL	34
-	-	2	2	2079383-5	SCR, BHSC, RoHS (M4 X 20)	33
-	-	2	2	2-2844962-8	SPACER, CYLINDRICAL, STRIP GUIDE	30
-	-	1	1	2844992-1	ASSEMBLY, STRIP GUIDE	29
-	-	1	1	1320928-2	STRIP GUIDE	24
-	-	1	1	2168083-2	SCR, SKT HD CAP, RoHS, M4 X 8.0	21
-	-	2	2	1-18028-2	WASHER, FLAT, REG M4	20
-	-	1	1	2119533-1	STRIPPER, SIDE FEED	19
-	-	1	1	2119806-1	INSERT, SHEAR	13
-	-	1	1	3-22280-3	SPRING, COMPRESSION	12
-	-	1	1	1-356885-4	STOP, SHEAR	11
-	-	1	1	2119805-1	SHEAR HOLDER, FRONT	10
-	-	1	1	1803095-6	FLOATING SHEAR, FRONT	9
1	1	2	2	1-1803293-4	ANVIL, COMBINATION DEUTSCH STYLE	8
-	-	1	1	2-240641-8	SPACER	7
-	-	-	-	-	-	6
-	-	1	1	2119757-3	DEPRESSOR, SHEAR	5
-	-	1	1	238011-9	BLOCK, CRIMPER SPACER	4
1	1	2	2	1803019-6	CRIMPER, INSULATION O	3
-	-	1	1	455888-8	SPACER, CRIMPER	2
-	-	1	2	1803364-2	CRIMPER, WIRE PREMIUM	1

REV	DATE	BY	CHK	DESCRIPTION	ITEM NO
16	16-Oct-13	R. KNEPPER			
16	16-Oct-13	G. BAILEY			
16	16-Oct-13	M. CLIFFORD			

Customer Accessible Production Drawing SCALE 1:2 SHEET 1 OF 4 REV H

LOC	DIST	REVISIONS					
A	66	P	LYN	DESCRIPTION	DATE	OWN	APVD
		-		SEE SHEET 1	-	-	-

# FEED TYPE MECHANICAL

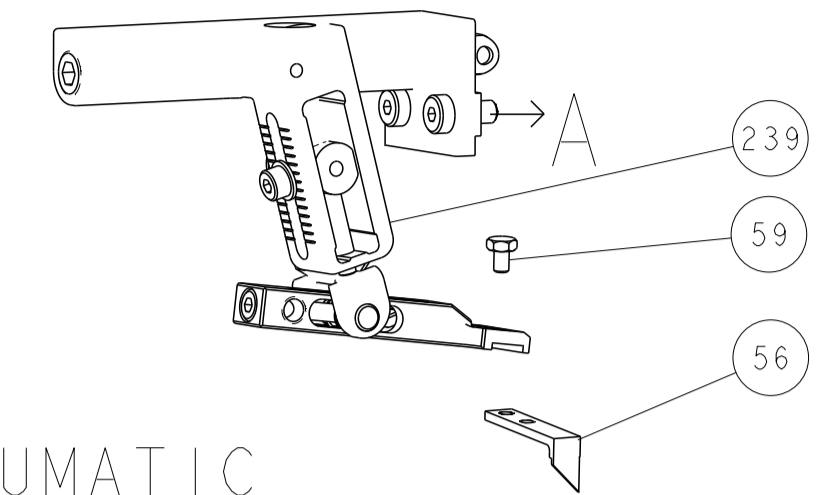

## PNEUMATIC

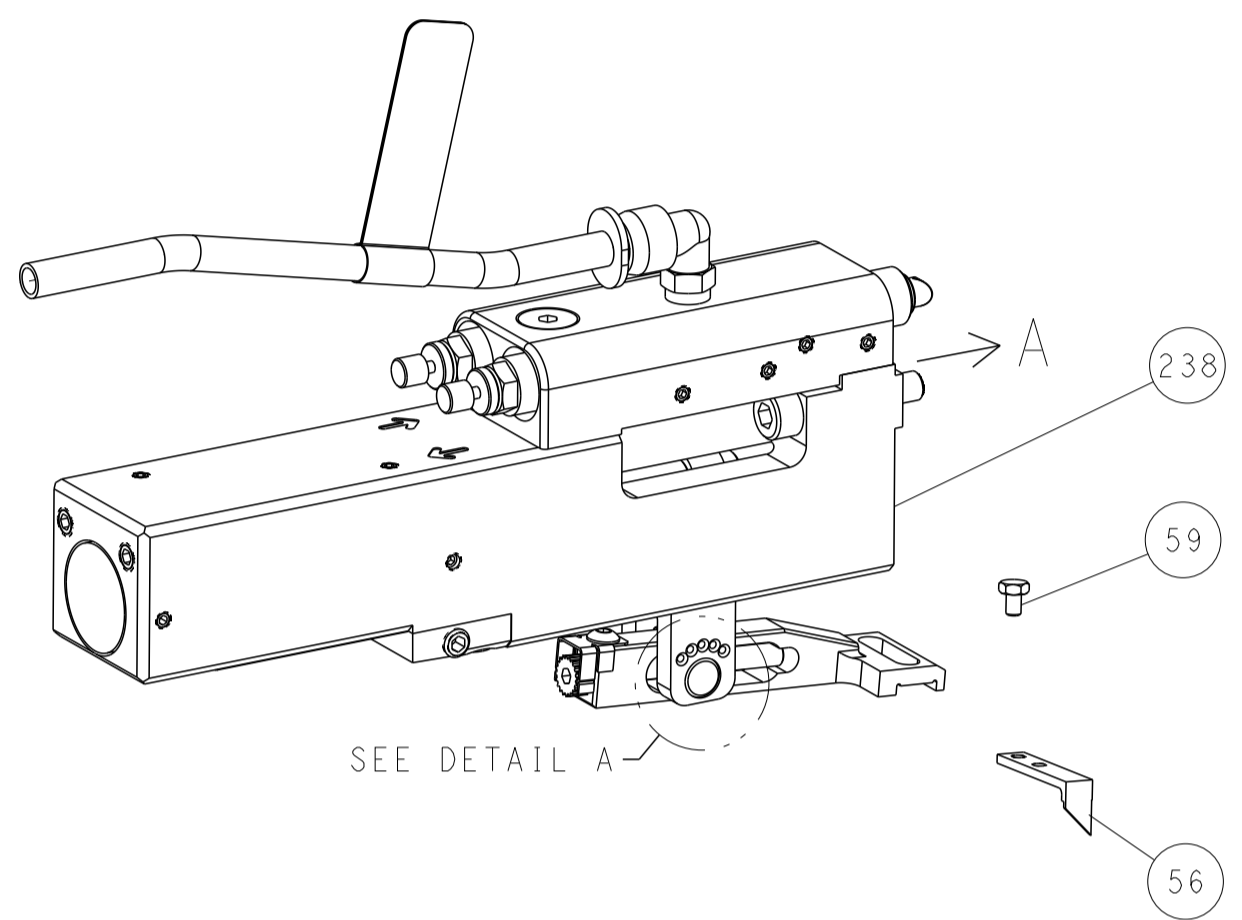

## FEED SPRING SETTING POSITION (SHOWN FROM REAR SIDE)



DETAIL A

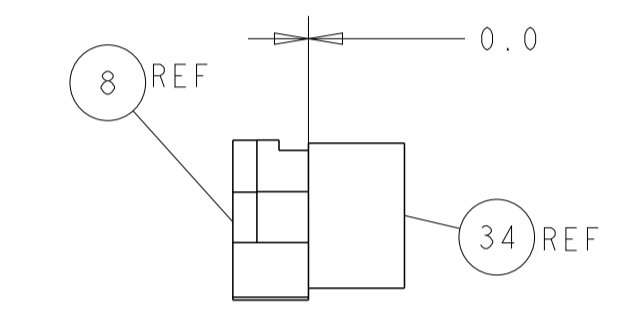
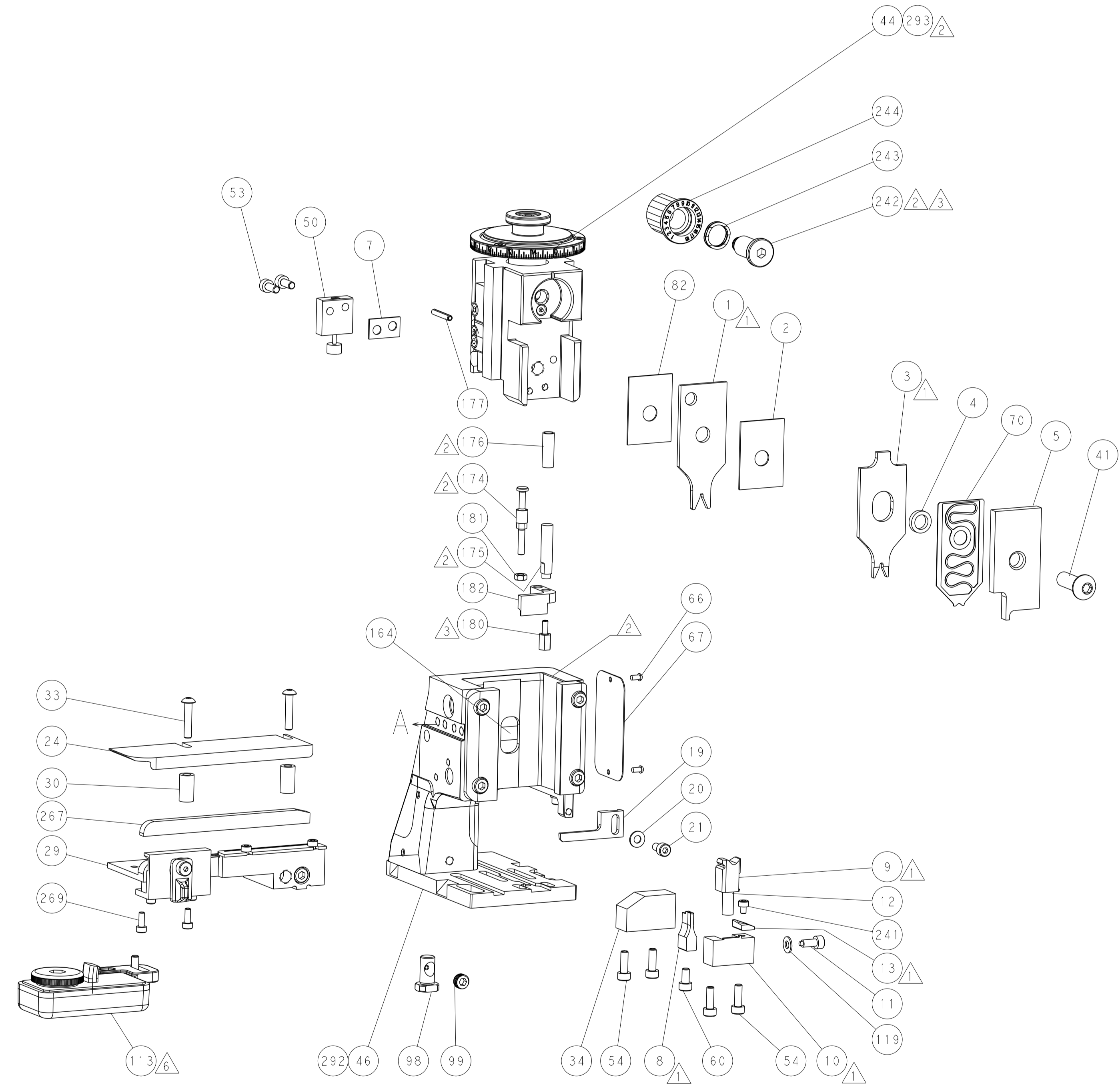

TERMINAL SUPPORT LOCATION

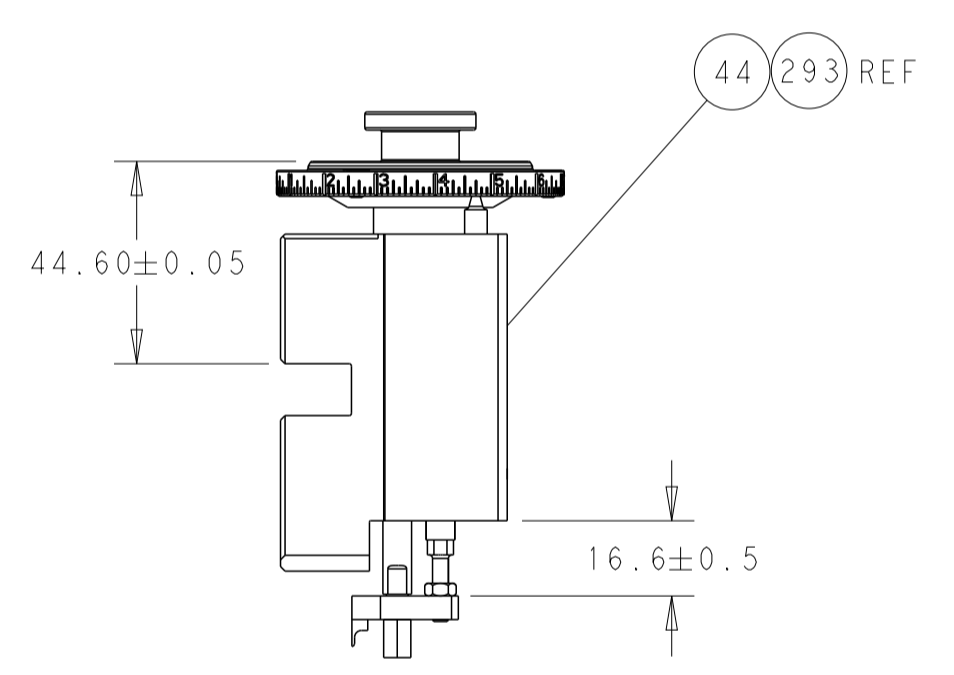

RAM AND HOLDDOWN SET-UP

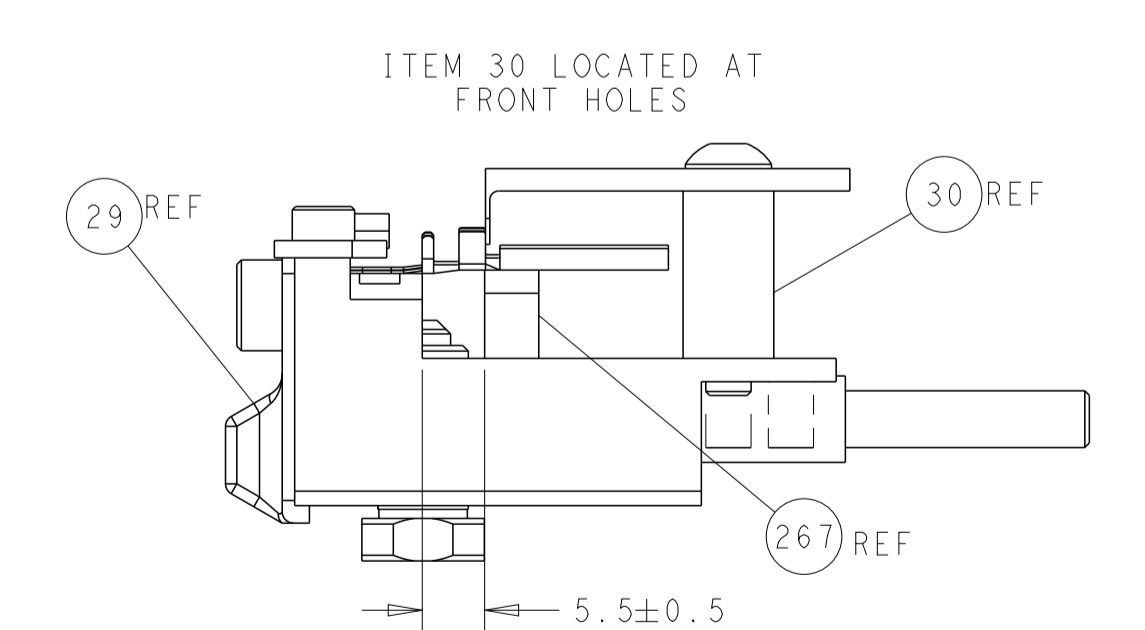

FEED TRACK POSITION GUIDE BY WIRE BARREL

# CAM POSITIONS

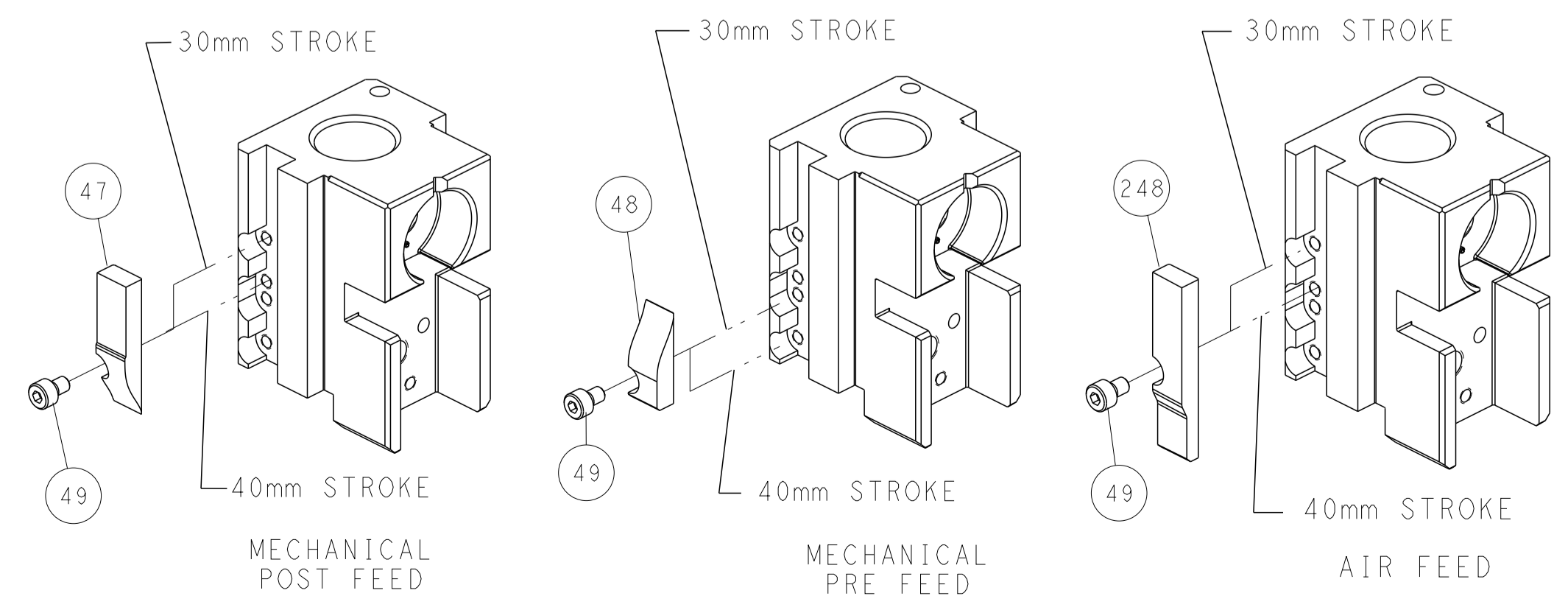

**ATLANTIC VERSION**  
 Shown on sheets 1 of 4 & 2 of 4  
 (Pacific version shown on sheets 3 of 4 & 4 of 4)

DIMENSIONS:		TOLERANCES UNLESS OTHERWISE SPECIFIED:		DWN R. KNEPPER 16-Oct-13		TE Connectivity	
mm	0 PLC ±	1 PLC ±	2 PLC ±	3 PLC ±	4 PLC ±	Harrisburg, PA 17105-3608	
MATERIAL:		FINISH:		CHK G. BAILEY 16-Oct-13		NAME Ocean Side Feed Applicator	
				APVD M. CLIFFORD 16-Oct-13		SIZE CAGE CODE DRAWING NO	
				PRODUCT SPEC		RESTRICTED TO	
				APPLICATION SPEC		A1 00779 ©=2266118	
				WEIGHT		SCALE 1:2 SHEET 2 OF 4 REV H	
				Customer Accessible Production Drawing		SHEETS 3 & 4 ARE NOT REQUIRED FOR ATLANTIC VERSION	

PART NUMBER	REVISION	DESCRIPTION	FEED TYPE
2-2266118-1	H	FINE CRIMP HEIGHT ADJUST	MECHANICAL
2-2266118-2	H	FINE CRIMP HEIGHT ADJUST	PNEUMATIC
7-2266118-7	C	CRIMP TOOLING KIT	-
7-2266118-8	C	APPLICATOR CONVERSION KIT	-

PACIFIC VERSION TERMINATOR  
INTERFACE ADAPTER



APPLICATOR DATA		
CRIMP	SIZE	TYPE
WIRE	1.75 mm [.069]	F
INSUL	2.03 mm [.080]	O

APPLICATOR INSTRUCTIONS  
408-35042

APPLICATOR CONVERSION KITS	
PART NUMBER	INSULATION DIAMETER RANGE
7-2266116-8	Ø2.74-3.18mm [.108-.125]
7-2266117-8	Ø2.31-2.72mm [.091-.107]
7-2266118-8	Ø1.91-2.29mm [.075-.090]
7-2266119-8	Ø1.60-2.16mm [.063-.085]
7-2266120-8	Ø1.27-1.57mm [.050-.062]

TERMINAL DATA: DEUTSCH TERMINAL DEUTSCH CRIMP SPECIFICATION			
TERMINAL NAME: STAMPED CONTACT PIN SIZE 20			
WIRE STRIP LENGTH	INSULATION DIAMETER RANGE	TE TERMINAL	DEUTSCH TERMINAL
3.81-5.09 mm [1.50-.200 IN]	Ø1.91-2.29 mm [.075-.090 IN]	1572032-1	1060-20-0122
114-151003	-	1572032-7	1060-20-0177

TERMINALS APPLIED

TE TERMINAL	DEUTSCH TERMINAL	TE TERMINAL	DEUTSCH TERMINAL
1572032-1	1060-20-0122	1572032-2	1060-20-0144
1572032-7	1060-20-0177		

TERMINAL DATA: DEUTSCH TERMINAL DEUTSCH CRIMP SPECIFICATION			
TERMINAL NAME: STAMPED CONTACT SOCKET SIZE 20			
WIRE STRIP LENGTH	INSULATION DIAMETER RANGE	TE TERMINAL	DEUTSCH TERMINAL
3.81-5.09 mm [1.50-.200 IN]	Ø1.91-2.29 mm [.075-.090 IN]	286680-1	1062-20-0122
114-151003	-	286680-9	1062-20-0177

TERMINALS APPLIED

TE TERMINAL	DEUTSCH TERMINAL	TE TERMINAL	DEUTSCH TERMINAL
286680-1	1062-20-0122	286680-2	1062-20-0144
286680-9	1062-20-0177	286680-5	1062-20-0322
286680-6	1062-20-0344	1-286680-0	1062-20-0377

WIRE SIZE	CRIMP HEIGHT mm [INCH]	CRIMP HEIGHT REFERENCE SETTING
1.50mm2	1.47+0.03/-0.05 [.058+.001/- .002]	3.4
16 AWG	1.27+0.03/-0.05 [.050+.001/- .002]	5.4
1.00mm2	1.27+0.03/-0.05 [.050+.001/- .002]	5.4
18 AWG	1.24+0.03/-0.05 [.049+.001/- .002]	5.7
0.75mm2	1.22+0.03/-0.05 [.048+.001/- .002]	5.9
0.60mm2	1.07+0.03/-0.05 [.042+.001/- .002]	7.4
20 AWG	0.99+0.03/-0.05 [.039+.001/- .002]	8.2
0.50mm2	0.97+0.03/-0.05 [.038+.001/- .002]	8.4
22 AWG	0.94+0.03/-0.05 [.037+.001/- .002]	8.7
0.35mm2	0.94+0.03/-0.05 [.037+.001/- .002]	8.7

- 1 RECOMMENDED SPARE PARTS
  - 2 REFER TO SUPPLIED INSTRUCTION SHEET FOR CLEANING, LUBRICATION & STORAGE OF APPLICATOR.
  - 3 APPLY PART NUMBER 2-23419-6 LOCTITE TO THREADS OF ITEM 242.
  - 4 CRIMP HEIGHT REFERENCE SETTING WAS THE SETTING USED WHEN THE APPLICATOR WAS QUALIFIED AT THE FACTORY. ADJUSTMENT MAY BE NECESSARY WHEN RUNNING APPLICATOR IN THE FIELD.
  - 5 SEE APPROPRIATE APPLICATOR LOG SHEETS FOR APPLIED TERMINALS, WIRE RANGE AND MEMORY CHIP.
  - 6 TERMINAL LUBRICANT IS RECOMMENDED.
7. UNLESS SPECIFIED OTHERWISE TORQUE VALUES SHALL BE USED PER DOCUMENT, 101-35000.

**\*WARNING**  
ON INSTALLATION, SET WIRE DISC TO CRIMP HEIGHT REFERENCE SETTING FOR LARGEST WIRE SIZE. CRIMP HEIGHT REFERENCE SETTINGS GREATER THAN THE VALUE SHOWN MAY CAUSE DAMAGE TO THE CRIMP TOOLING, REFER TO THE INSTRUCTION SHEET FOR PROPER SETUP AND ADJUSTMENTS.

PACIFIC VERSION  
Shown on sheets 3 of 4 & 4 of 4  
(Atlantic version shown on sheets 1 of 4 & 2 of 4)

LOC	DIST	REV	DATE	BY	APPD
A	66	-	-	-	-

REV	DATE	BY	APPD	DESCRIPTION	ITEM NO	
-	-	2	2	2168083-1	SCR, SKT HD CAP, RoHS, M3 X 8.0	269
-	-	1	1	2-1633782-0	FENCE	267
-	-	1	1	2119082-9	CAM, SNAIL, INSULATION ADJUSTMENT	244
-	-	1	1	2079764-1	WASHER, WAVE SPRING, CREST-TO-CREST	243
-	-	1	1	2119083-1	RETAINER, INSULATION DIAL	242
-	-	1	1	7-18023-7	SCR, SKT HD CAP M3 X 4.0	241
-	-	-	1	2119580-1	MECHANICAL FEED ASSEMBLY	239
-	-	1	-	2844940-1	AIR FEED MODULE	238
-	-	REF	REF	994970-2	COUNTER, MAGNETIC	164
-	-	1	-	2119641-2	FEED CAM, AIR FEED	151
-	-	1	1	2168083-8	SCR, SKT HD CAP, RoHS, M4 X 16	144
-	-	4	4	2168083-9	SCR, SKT HD CAP, RoHS, M4 X 20	143
-	-	-	1	2119653-2	FEED CAM, POST FEED	142
-	-	1	1	1-1803583-0	APPLICATOR BASIC ASSEMBLY, SF	141
-	-	1	1	1803516-1	RAM ASSEMBLY, SF PACIFIC	140
-	-	1	1	1-18028-2	WASHER, FLAT, REG M4	119
-	-	1	1	2119955-1	ASSY, LUBRICATOR, SIDE FEED	113
-	-	1	1	2844908-1	SCREW, LOCKING	99
-	-	1	1	2844907-1	POST, LOCKING	98
-	-	1	1	455888-7	SPACER, CRIMPER	82
1	-	-	-	2266118	PRINT, APPLICATOR LOG SHEET	72
-	-	1	1	1803607-3	DOCUMENTATION PACKAGE	71
-	-	1	1	2119791-9	DEPRESSOR, WIRE	70
-	-	1	1	2119740-1	TAG IDENTIFICATION	67
-	-	2	2	2168078-1	SCREW, DRIVE, RH, RoHS, 2 x .188	66
-	-	1	1	5-18022-5	SCR, HEX HD CAP, M4 X 6.0	59
-	-	1	1	1338685-1	PAWL, FEED	56
-	-	2	2	1-2168083-0	SCR, SKT HD CAP, RoHS, M4 X 10	53
-	-	1	1	1803382-6	HOLD DOWN, SPRING LOADED	50
-	-	1	2	18023-9	SCR, SKT HD CAP M4 X 6.0	49
-	-	-	1	2119652-1	FEED CAM, PRE FEED	48
-	-	1	1	1803602-1	SCR, BHSC, RoHS (M8 X 25)	41
-	-	1	1	2-1752356-0	SUPPORT, TERMINAL	34
-	-	2	2	2079383-5	SCR, BHSC, RoHS (M4 X 20)	33
-	-	2	2	2-2844962-8	SPACER, CYLINDRICAL, STRIP GUIDE	30
-	-	1	1	2844992-1	ASSEMBLY, STRIP GUIDE	29
-	-	1	1	1320928-2	STRIP GUIDE	24
-	-	1	1	2168083-2	SCR, SKT HD CAP, RoHS, M4 X 8.0	21
-	-	1	1	1-18028-2	WASHER, FLAT, REG M4	20
-	-	1	1	2119533-1	STRIPPER, SIDE FEED	19
-	-	1	1	2119806-1	INSERT, SHEAR	13
-	-	1	1	3-22280-3	SPRING, COMPRESSION	12
-	-	1	1	1-356885-4	STOP, SHEAR	11
-	-	1	1	2119805-1	SHEAR HOLDER, FRONT	10
-	-	1	1	1803095-6	FLOATING SHEAR, FRONT	9
1	1	1	1	1-1803293-4	ANVIL, COMBINATION DEUTSCH STYLE	8
-	-	1	1	2-240641-8	SPACER	7
-	-	-	-	-	-	6
-	-	1	1	2119757-3	DEPRESSOR, SHEAR	5
-	-	1	1	238011-9	BLOCK, CRIMPER SPACER	4
1	1	1	1	1803019-6	CRIMPER, INSULATION O	3
-	-	1	1	455888-8	SPACER, CRIMPER	2
-	-	1	1	1803364-2	CRIMPER, WIRE PREMIUM	1

ITEM NO	DESCRIPTION	REV				
-78	-77	-22	-21	PART NO	DESCRIPTION	ITEM NO

DIMENSIONS: mm 	TOLERANCES UNLESS OTHERWISE SPECIFIED: 0 PLC ± 1 PLC ± 2 PLC ± 3 PLC ± 4 PLC ± ANGLES ± FINISH	DWN R. KNEPPER 16-Oct-13 CHK G. BAILEY 16-Oct-13 APVD M. CLIFFORD 16-Oct-13 PRODUCT SPEC APPLICATION SPEC WEIGHT SCALE 1:2 SHEET 3 OF 4 REV H	NAME Ocean Side Feed Applicator SIZE CAGE CODE DRAWING NO A1 00779 C=2266118
-----------------------	---	---	--

LOC	DIST	REVISIONS					
A	66	P	LTN	DESCRIPTION	DATE	DWN	APVD
		-		SEE SHEET 1			

# FEED TYPE MECHANICAL

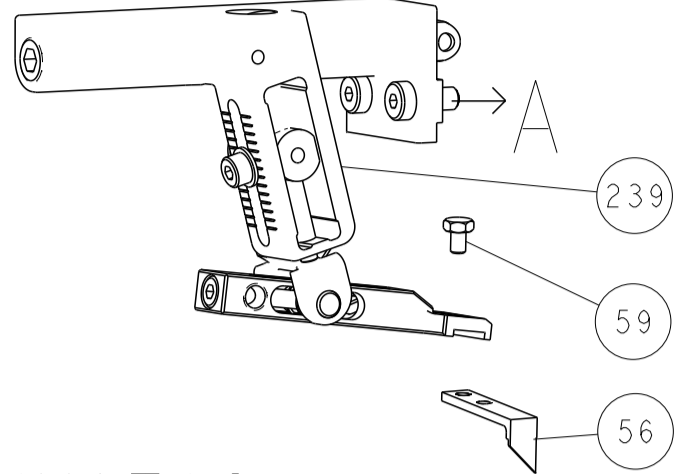

## PNEUMATIC

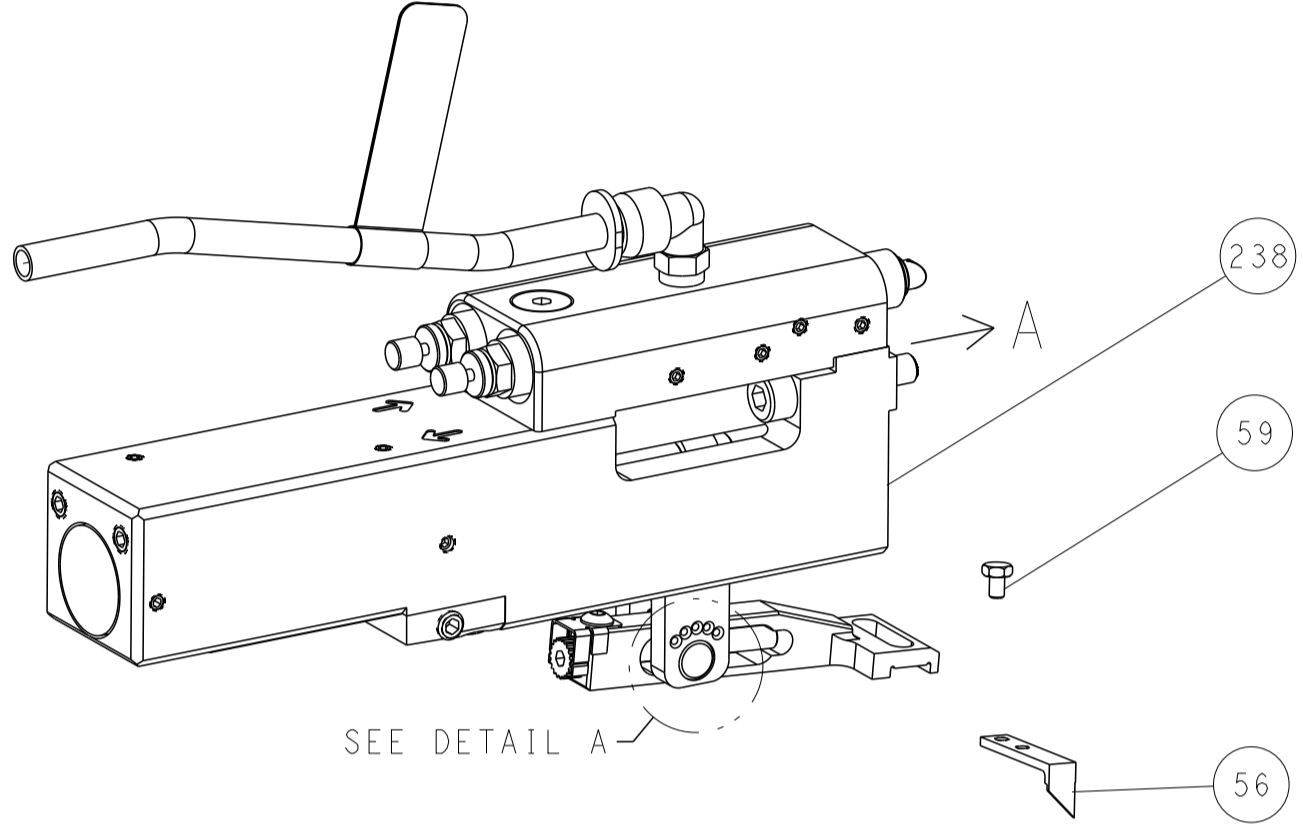

## FEED SPRING SETTING POSITION (SHOWN FROM REAR SIDE)



DETAIL A

## CAM POSITIONS

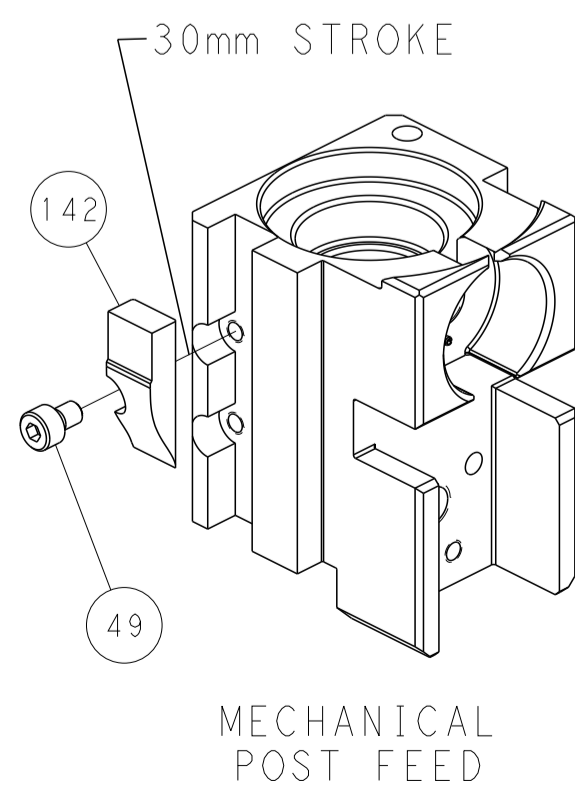

MECHANICAL POST FEED

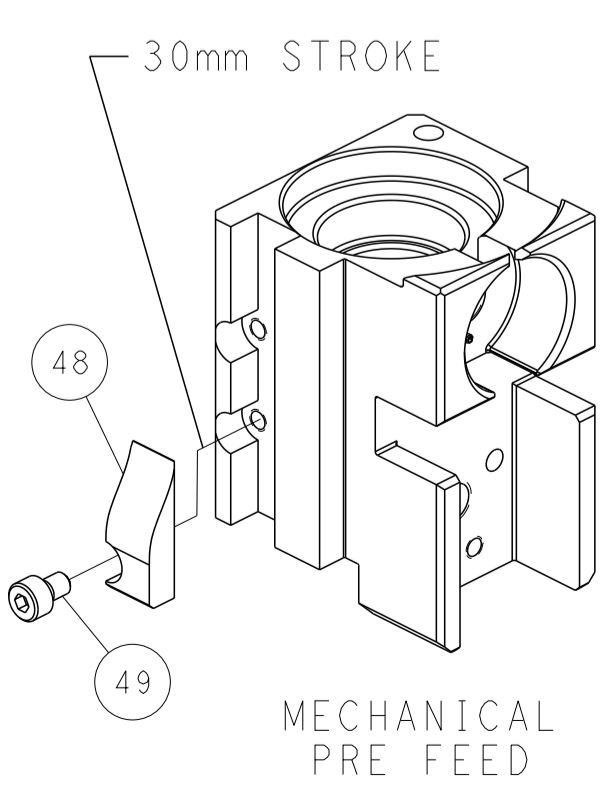

MECHANICAL PRE FEED

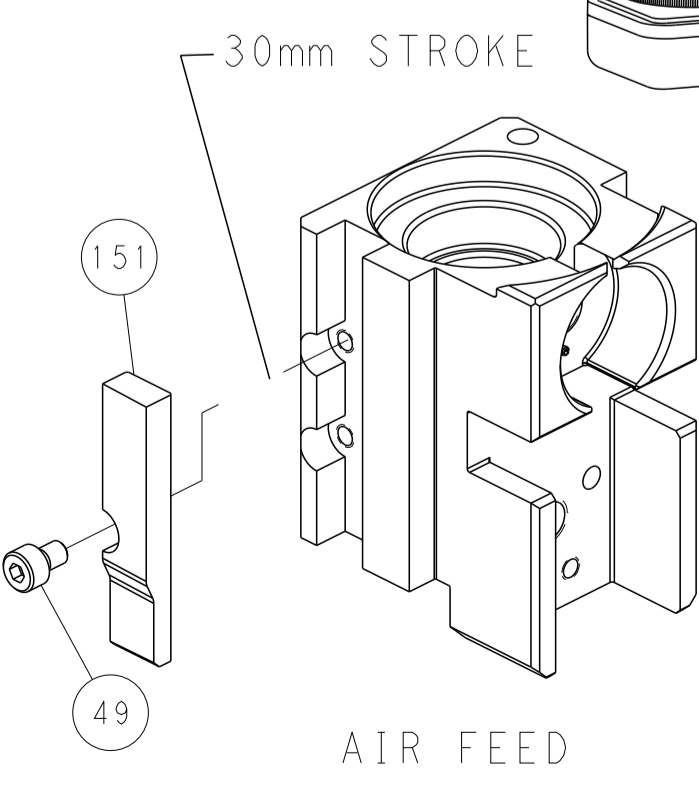

AIR FEED

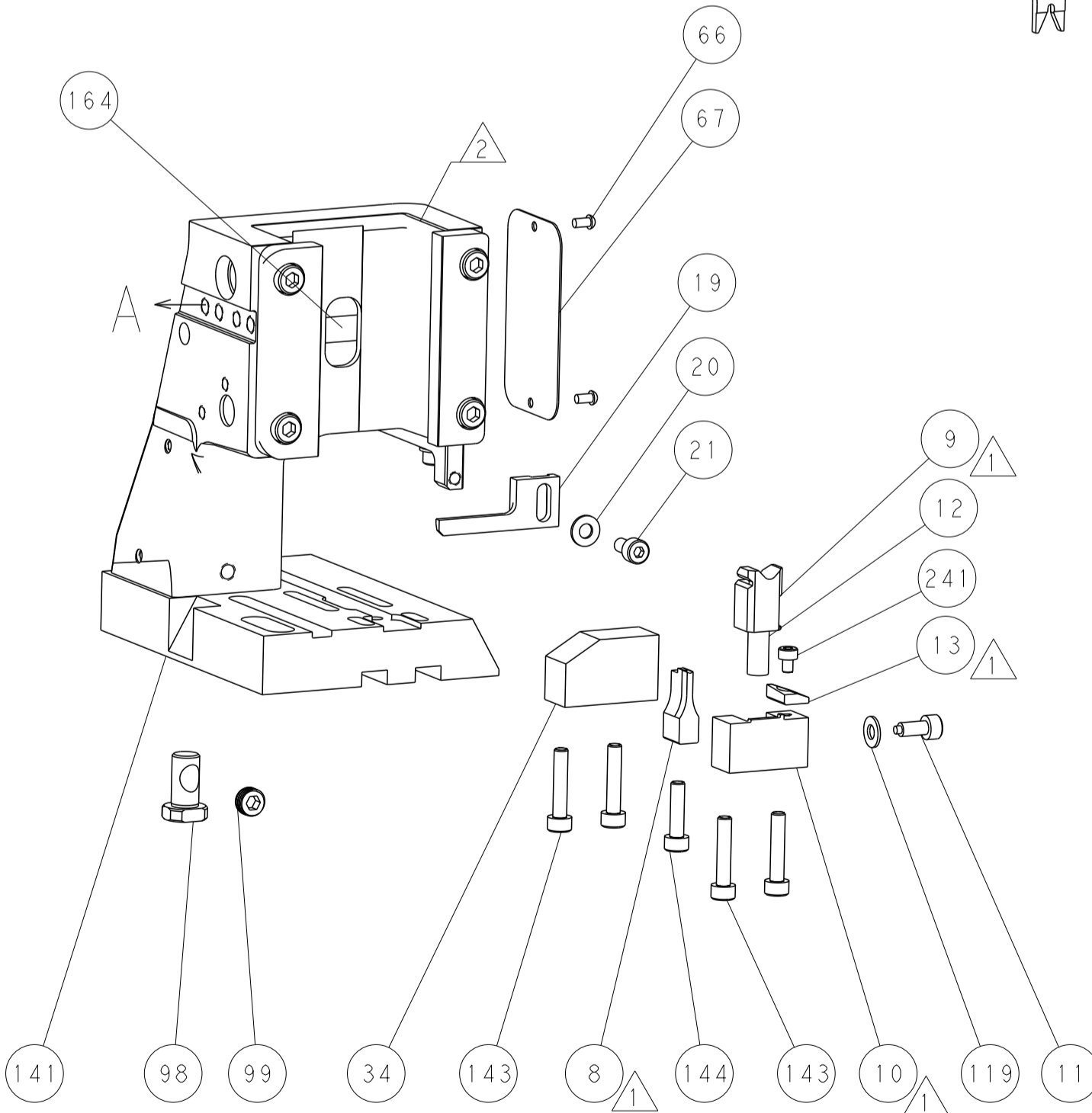
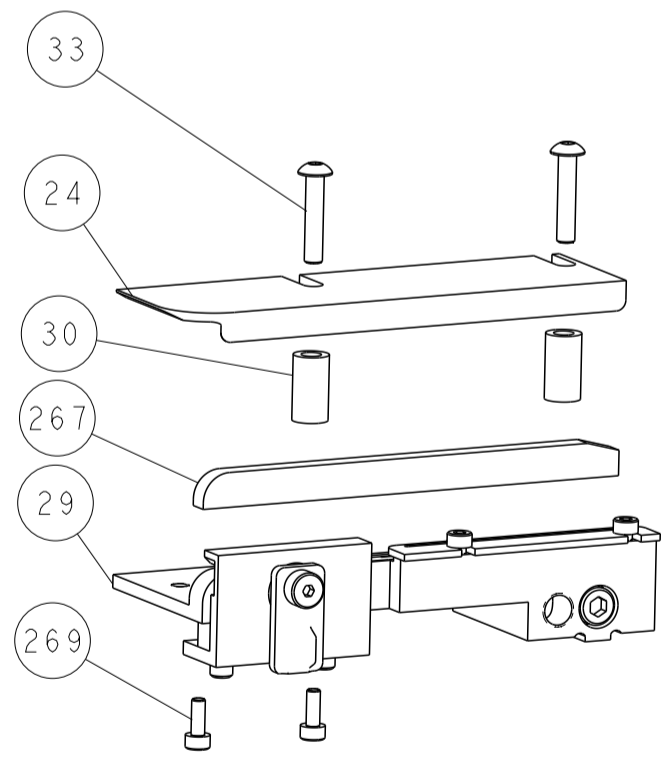

**PACIFIC VERSION**  
 Shown on sheets 3 of 4 & 4 of 4  
 (Atlantic version shown on sheets 1 of 4 & 2 of 4)

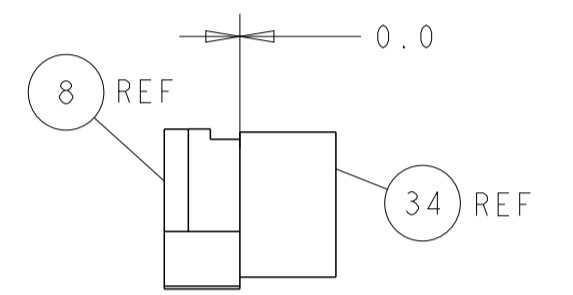
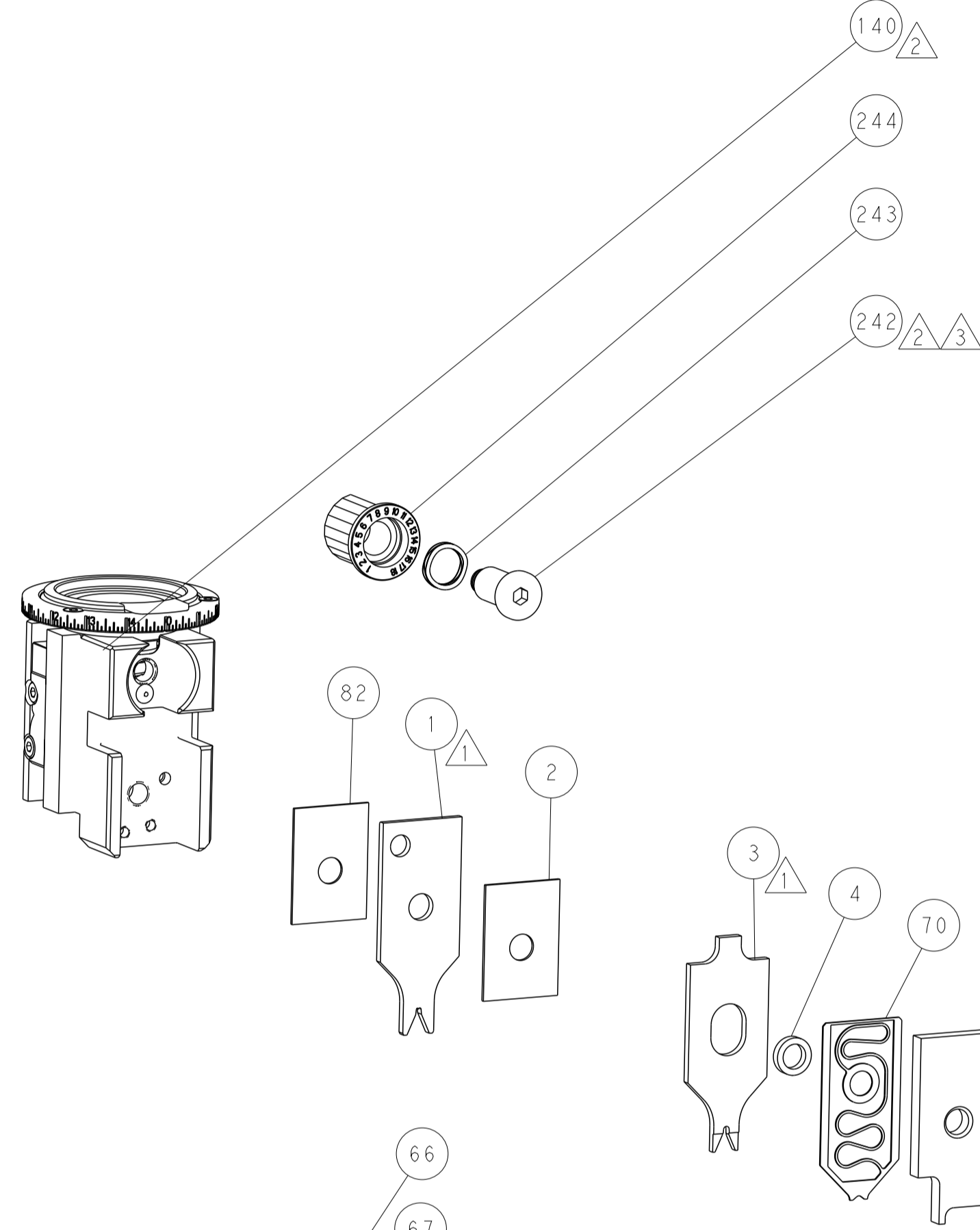

TERMINAL SUPPORT LOCATION

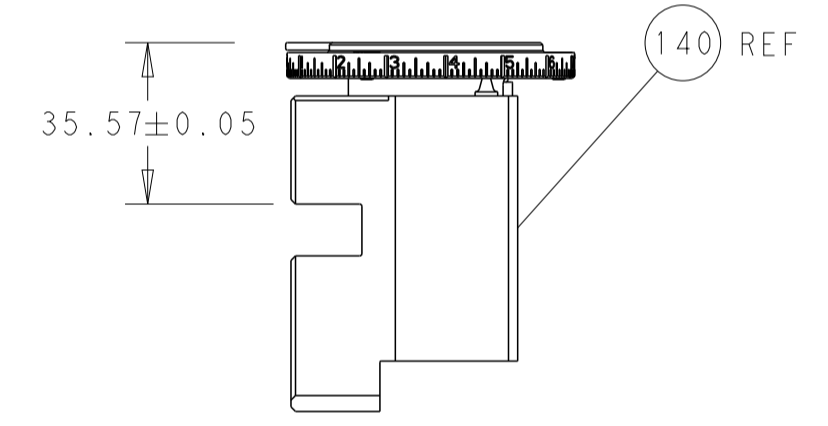

RAM SET-UP

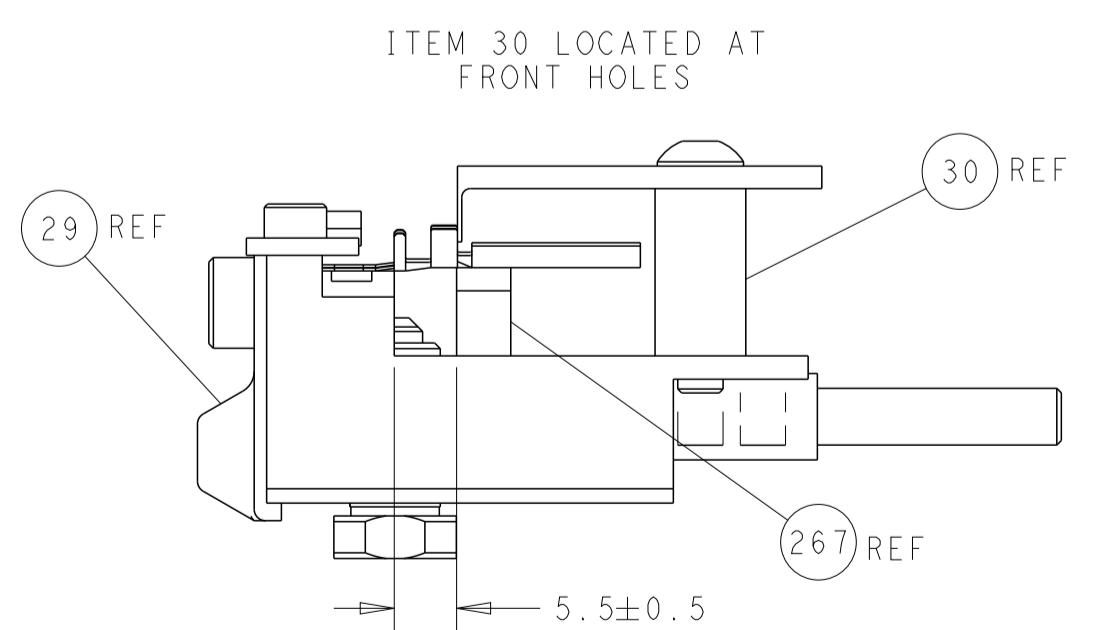

FEED TRACK POSITION GUIDE BY WIRE BARREL

DIMENSIONS: mm 		TOLERANCES UNLESS OTHERWISE SPECIFIED: 0 PLC ± 1 PLC ± 2 PLC ± 3 PLC ± 4 PLC ± ANGLES ± FINISH ±		DWN R. KNEPPER 16-Oct-13 CHK G. BAILEY 16-Oct-13 APVD M. CLIFFORD 16-Oct-13 PRODUCT SPEC APPLICATION SPEC WEIGHT Customer Accessible Production Drawing		NAME Ocean Side Feed Applicator SIZE CAGE CODE DRAWING NO A1 00779 C=2266118 SCALE 1:2 SHEET 4 OF 4 REV H		RESTRICTED TO	
-----------------------	--	---	--	---	--	---	--	---------------	--