

NOTES:  
 1) THIS SOCKET COMPLIES WITH ALL SPECIFICATIONS AND PERFORMANCE REQUIREMENTS FOR INTEL rPGA98X SERIES CPU PROCESSORS.  
 2) SOCKET SHOWN IN OPEN POSITION.  
 3) SEE SHEET 2 FOR DETAILS PERTAINING TO KEYING, MATERIAL AND PACKAGING OPTIONS.  
 4) THIS PRODUCT SERIES COMPLIANT TO RoHS DIRECTIVE 2002/95/EC AND ELV DIRECTIVE 2000/53/EC.

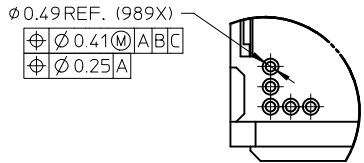
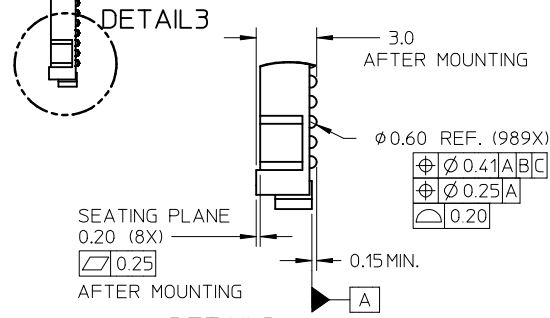
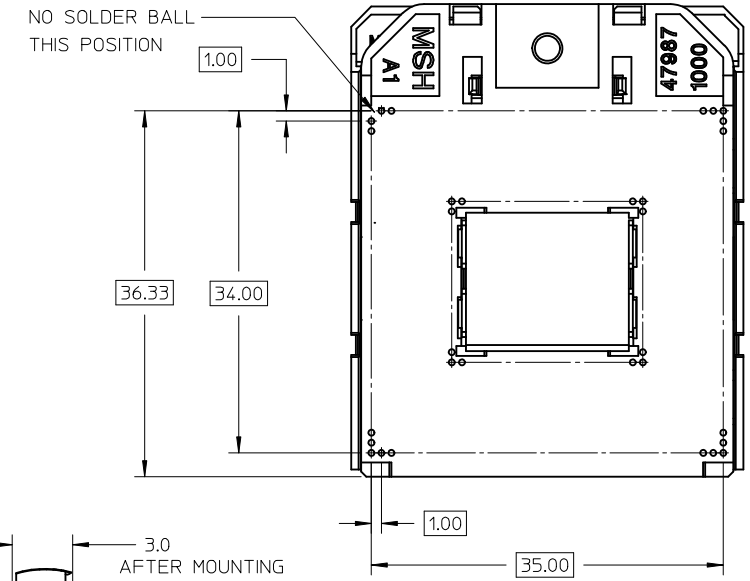

DETAIL2

REVISED EC NO: SH2011-0076 DRW:ZYYAN CHKD: APPR:AYIN REV B	DESCRIPTION 2010/09/03 2010/09/06 2010/09/17	QUALITY SYMBOLS	GENERAL TOLERANCES (UNLESS SPECIFIED)		DIMENSION STYLE	SCALE	DESIGN UNITS	THIRD ANGLE PROJECTION
		$\nabla_A = 0$ $\nabla_C = 0$ $\nabla_P = 0$	mm	INCH	MM ONLY	2:1	METRIC	
		4 PLACES ± --- ± --- 3 PLACES ± --- ± --- 2 PLACES ± 0.10 ± --- 1 PLACE ± 0.20 ± ---	DRAWN BY QWFANG DATE 2008/04/25		TITLE RPGA989 SOCKET ASSEMBLY			
		ANGULAR ± 2 °	CHECKED BY JKACH LIC DATE 2008/05/29		APPROVED BY CL IANG DATE 2008/05/29			
DRAFT WHERE APPLICABLE MUST REMAIN WITHIN DIMENSIONS		MATERIAL NO. SEE TABLE		MOLEX INCORPORATED		DOCUMENT NO. SD-47989-001		SHEET NO. 1 OF 6
		SIZE A3		THIS DRAWING CONTAINS INFORMATION THAT IS PROPRIETARY TO MOLEX INCORPORATED AND SHOULD NOT BE USED WITHOUT WRITTEN PERMISSION				

REMOVEABLE PICK & PLACE CAP

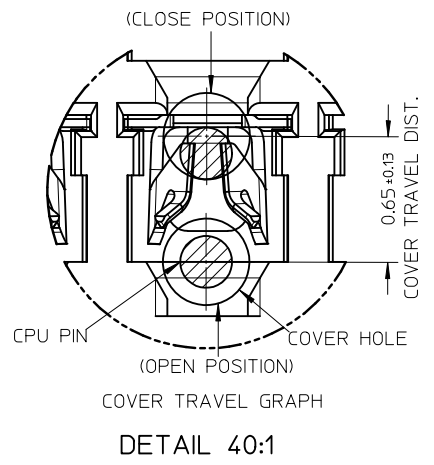
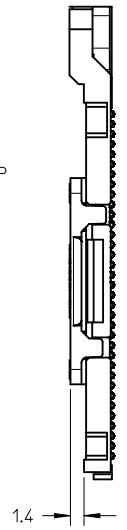
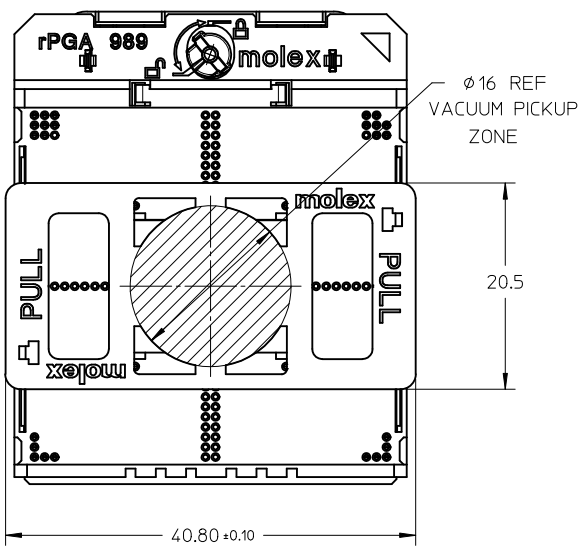

NOTES:

- 1) MATERIALS:  
 MOLDED COMPONENTS: LIQUID CRYSTAL POLYMER (LCP) UL 94V-0  
 BASE HOUSING COLOR: BLACK  
 COVER COLOR: NATURAL  
 MYLAR(POLYIMIDE, COLOR:ORANGE) OR PhP COVER(LCP, COLOR: BLACK)  
 FOR PICK & PLACE.  
 CONTACTS: HIGH STRENGTH COPPER ALLOY  
 PLATING: GOLD THICKNESS AS FOLLOWING TABLE 1-3 IN CONTACT AREA,  
 1.3um NICKEL OVERALL  
 CAM COMPONENTS: STAINLESS STEEL  
 SOLDER BALL: LEAD-FREE BALL SnAg3.0Cu0.5
- 2) DATE CODE \*\*\*\*\*  
 MOLEX INTERNAL USE  
 WORKING DAY  
 MONTH  
 YEAR
- 3) PRODUCT SPECIFICATION PS-47989-00\* APPLIES  
 4) PACKAGING SPECIFICATION: PK-47989-001 (TAPE & REEL)  
 PK-47989-002 (HARD TRAY)

REVISED EC NO: SH2011-0076 DRWN:ZYUAN CHKD: APPR:AYIN	2010/09/03 2010/09/06 2010/09/17	DESCRIPTION REV	QUALITY SYMBOLS	GENERAL TOLERANCES (UNLESS SPECIFIED)	DIMENSION STYLE	SCALE	DESIGN UNITS	THIRD ANGLE PROJECTION	
			▽F=0	mm INCH	MM ONLY	2:1	METRIC	□	
			▽F=0	4 PLACES ± --- ± ---	DRAWN BY DATE	TITLE	MATERIAL NO.	DOCUMENT NO.	SHEET NO.
			▽F=0	3 PLACES ± --- ± ---	QWFANG 2008/04/25				
			2 PLACES ± 0.10 ± ---	CHECKED BY DATE					
			1 PLACE ± 0.20 ± ---	APPROVED BY DATE					
			ANGULAR ± 2 °	CL IANG 2008/05/29					
			DRAFT WHERE APPLICABLE MUST REMAIN WITHIN DIMENSIONS	SEE TABLE					
				SIZE A3	THIS DRAWING CONTAINS INFORMATION THAT IS PROPRIETARY TO MOLEX INCORPORATED AND SHOULD NOT BE USED WITHOUT WRITTEN PERMISSION				

PART NO. OF GF PLATING- TABLE 1

PART NUMBER	PICK UP TYPE		PACKAGE TYPE		PRODUCT SPEC.
	MYLAR	CAP	T&R	HARD TRAY	
47989-0110	◆			◆	PS-47989-002
47989-0120	◆		◆		
47989-0130		◆		◆	
47989-0140		◆	◆		
47989-0210	◆			◆	
47989-0220	◆		◆		
47989-0230		◆		◆	
47989-0240		◆	◆		

PART NO. OF 10u" MIN. GOLD PLATING- TABLE 2

PART NUMBER	PICK UP TYPE		PACKAGE TYPE		PRODUCT SPEC.
	MYLAR	CAP	T&R	HARD TRAY	
47989-0111	◆			◆	PS-47989-003
47989-0121	◆		◆		
47989-0131		◆		◆	
47989-0141		◆	◆		
47989-0211	◆			◆	
47989-0221	◆		◆		
47989-0231		◆		◆	
47989-0241		◆	◆		

PART NO. OF 15u" MIN. GOLD PLATING- TABLE 3

PART NUMBER	PICK UP TYPE		PACKAGE TYPE		PRODUCT SPEC.
	MYLAR	CAP	T&R	HARD TRAY	
47989-0112	◆			◆	PS-47989-001
47989-0122	◆		◆		
47989-0132		◆		◆	
47989-0142		◆	◆		
47989-0212	◆			◆	
47989-0222	◆		◆		
47989-0232		◆		◆	
47989-0242		◆	◆		

SOCKET KEYING OPTIONS

MYLAR PICK & PLACE OPTION

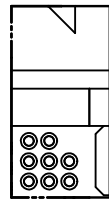
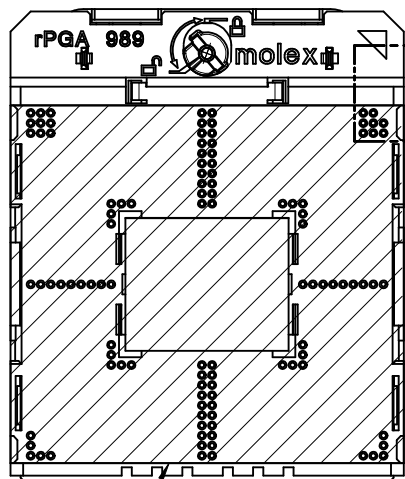

rPGA989  
47989-01\*\*

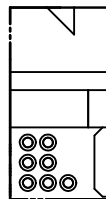

rPGA988A  
47989-02\*\*

REVISED EC NO: SH2011-0076 DRWN:ZYAN CHKD: APPR:AYIN 2010/09/03 2010/09/06 2010/09/17	QUALITY SYMBOLS $F_A=0$ $F_C=0$ $F_P=0$	GENERAL TOLERANCES (UNLESS SPECIFIED)		DIMENSION STYLE MM ONLY		SCALE 2:1	DESIGN UNITS METRIC	THIRD ANGLE PROJECTION		
			mm	INCH	DRAWN BY	DATE	TITLE			
		4 PLACES	± ---	± ---	QWFANG	2008/04/25	RPGA989 SOCKET ASSEMBLY			
		3 PLACES	± ---	± ---	CHECKED BY	DATE	MOLEX INCORPORATED			
2 PLACES	± 0.10	± ---	JKACHLIC	2008/05/29	MATERIAL NO.					
1 PLACE	± 0.20	± ---	APPROVED BY	DATE	DOCUMENT NO.					
	ANGULAR ± 2 °		CL IANG	2008/05/29	SD-47989-001					
DRAFT WHERE APPLICABLE MUST REMAIN WITHIN DIMENSIONS		SEE TABLE		SHEET NO.						
		SIZE A3		3 OF 6						
THIS DRAWING CONTAINS INFORMATION THAT IS PROPRIETARY TO MOLEX INCORPORATED AND SHOULD NOT BE USED WITHOUT WRITTEN PERMISSION										

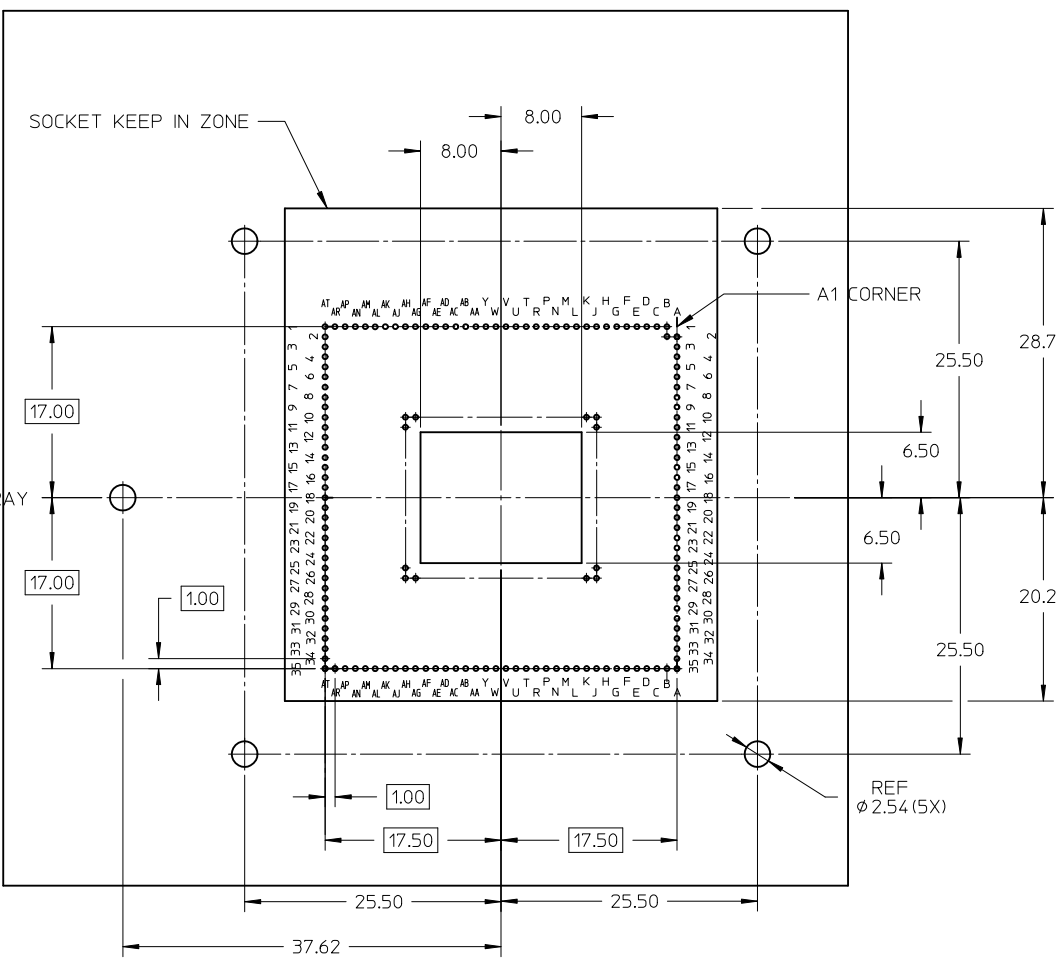

NOTES:

shape pada of PCB are recommended

TYPE1-Corner Pads

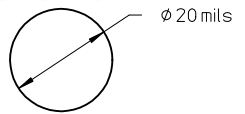

TYPE2-Peripheral Pads(Oblong-shape pada are recommended)

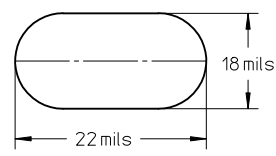

TYPE3-All Other Location Except for those of Type1 and Type2 Locations)

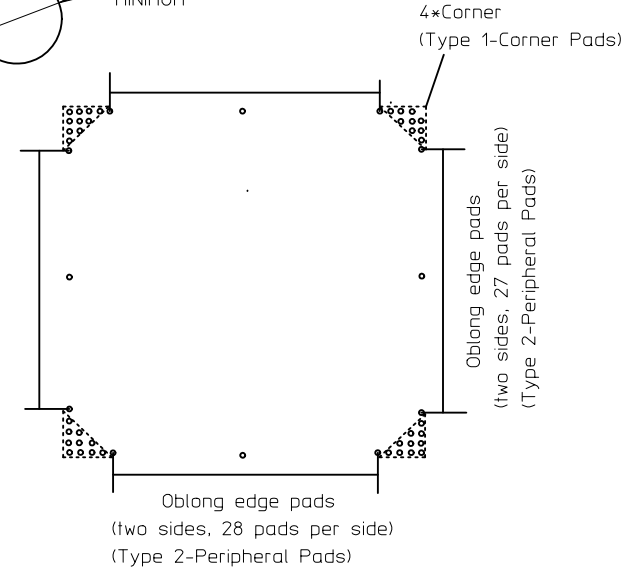
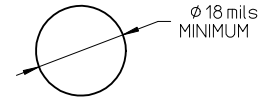

MOTHERBOARD KEEP IN ZONE (KIZ)  
(FOR NORMAL)

REVISED EC NO: SH2011-0076 DRWN:ZYAN CHKD: APPR:AYIN	2010/09/03 2010/09/06 2010/09/17	DESCRIPTION REV	QUALITY SYMBOLS	GENERAL TOLERANCES (UNLESS SPECIFIED)		DIMENSION STYLE		SCALE	DESIGN UNITS	THIRD ANGLE PROJECTION
			$F_A = 0$ $F_C = 0$ $F_D = 0$	mm	INCH	MM ONLY		METRIC		
			4 PLACES ± --- ± --- 3 PLACES ± --- ± --- 2 PLACES ± 0.10 ± --- 1 PLACE ± 0.20 ± --- ANGULAR ± 2 °	DRAWN BY QWFANG		DATE 2008/04/25	TITLE RPGA989 SOCKET ASSEMBLY			
			DRAFT WHERE APPLICABLE MUST REMAIN WITHIN DIMENSIONS	CHECKED BY JKACHLIC		DATE 2008/05/29	APPROVED BY CL IANG			DATE 2008/05/29
MATERIAL NO. SEE TABLE		THIS DRAWING CONTAINS INFORMATION THAT IS PROPRIETARY TO MOLEX INCORPORATED AND SHOULD NOT BE USED WITHOUT WRITTEN PERMISSION								

PART NO. OF GF PLATING- TABLE 1

PART NUMBER	PICK UP TYPE		PACKAGE TYPE		PRODUCT SPEC.
	MYLAR	CAP	T&R	HARD TRAY	
47989-9110	◆			◆	PS-47989-002
47989-9120	◆		◆	◆	
47989-9130		◆		◆	
47989-9140		◆	◆	◆	
47989-9210	◆			◆	
47989-9220	◆		◆	◆	
47989-9230		◆		◆	
47989-9240		◆	◆	◆	

PART NO. OF 10u" MIN. GOLD PLATING- TABLE 2

PART NUMBER	PICK UP TYPE		PACKAGE TYPE		PRODUCT SPEC.
	MYLAR	CAP	T&R	HARD TRAY	
47989-9111	◆			◆	PS-47989-003
47989-9121	◆		◆		
47989-9131		◆		◆	
47989-9141		◆	◆	◆	
47989-9211	◆			◆	
47989-9221	◆		◆	◆	
47989-9231		◆		◆	
47989-9241		◆	◆	◆	

PART NO. OF 15u" MIN. GOLD PLATING- TABLE 3

PART NUMBER	PICK UP TYPE		PACKAGE TYPE		PRODUCT SPEC.
	MYLAR	CAP	T&R	HARD TRAY	
47989-9112	◆			◆	PS-47989-001
47989-9122	◆		◆		
47989-9132		◆		◆	
47989-9142		◆	◆	◆	
47989-9212	◆			◆	
47989-9222	◆		◆	◆	
47989-9232		◆		◆	
47989-9242		◆	◆	◆	

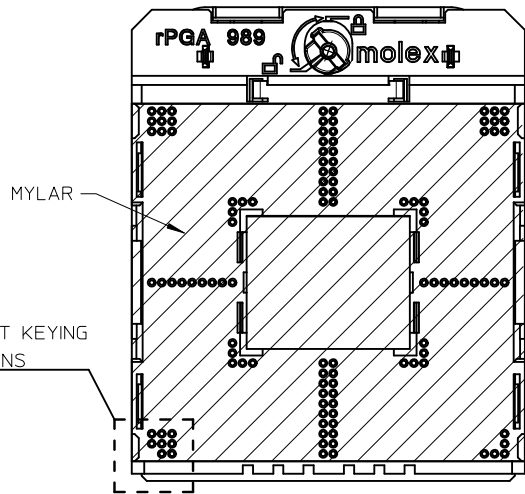
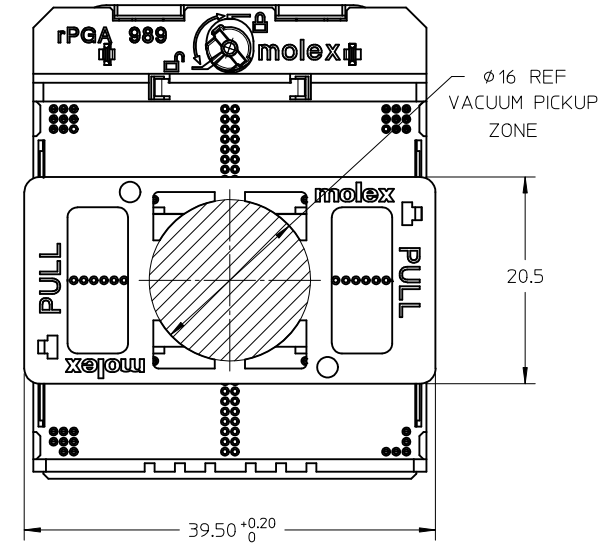

(180° ROTATION)

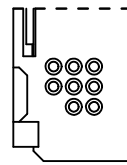

rPGA989  
47989-91\*\*

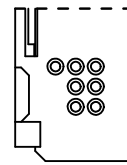

rPGA988A  
47989-92\*\*

REVISED EC NO: SH2011-0076 DRWN:ZYAN CHKD: APPR:AYIN	2010/09/03	2010/09/06	2010/09/17	QUALITY SYMBOLS $F_A=0$ $F_C=0$ $F_P=0$	GENERAL TOLERANCES (UNLESS SPECIFIED) mm INCH 4 PLACES ± --- ± --- 3 PLACES ± --- ± --- 2 PLACES ± 0.10 ± --- 1 PLACE ± 0.20 ± --- ANGULAR ± 2 °	DIMENSION STYLE MM ONLY DRAWN BY QWFANG CHECKED BY JKACHLIC APPROVED BY CL IANG DATE 2008/04/25 DATE 2008/05/29 DATE 2008/05/29	SCALE 2:1 DESIGN UNITS METRIC THIRD ANGLE PROJECTION	TITLE RPGA989 SOCKET ASSEMBLY			
	REV B	REV	MATERIAL NO. SEE TABLE						DOCUMENT NO. SD-47989-001	SHEET NO. 5 OF 6	
	DRAFT WHERE APPLICABLE MUST REMAIN WITHIN DIMENSIONS								THIS DRAWING CONTAINS INFORMATION THAT IS PROPRIETARY TO MOLEX INCORPORATED AND SHOULD NOT BE USED WITHOUT WRITTEN PERMISSION		

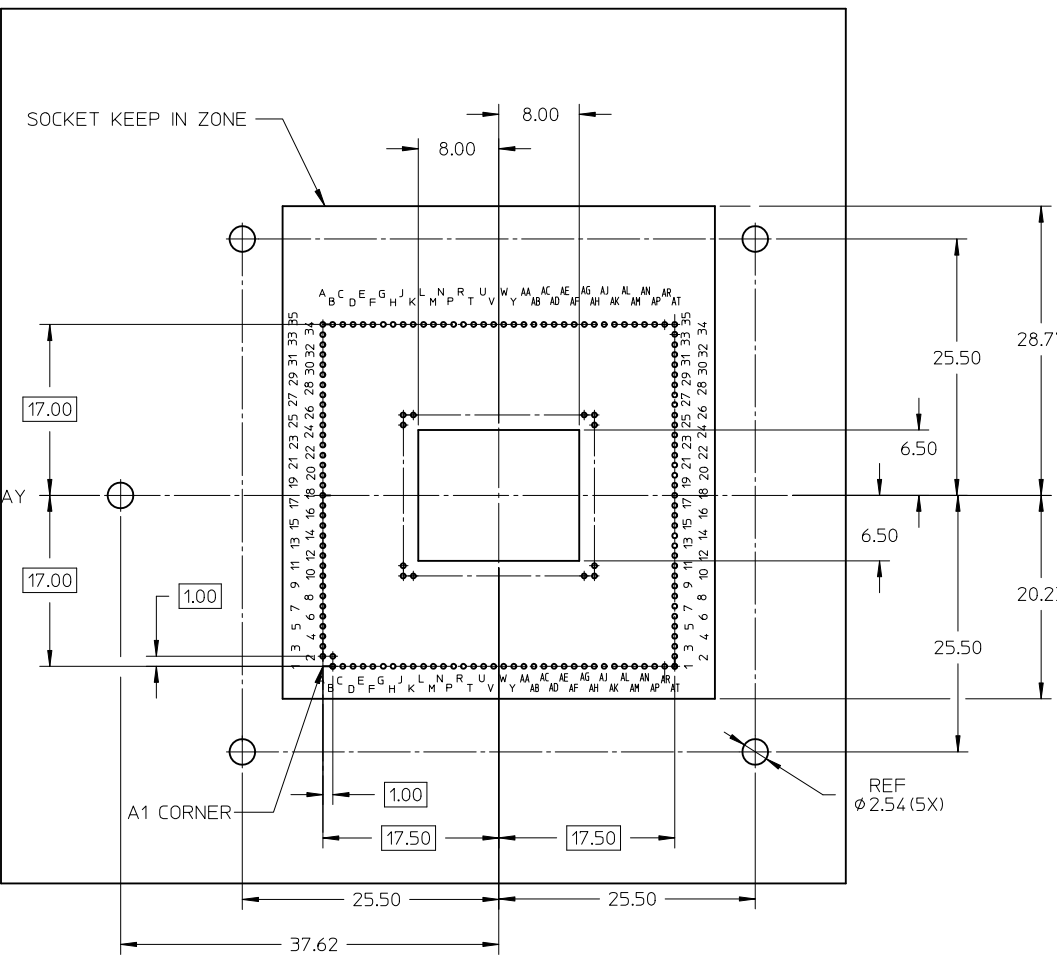

NOTES:

shape pada of PCB are recommended

TYPE1-Corner Pads

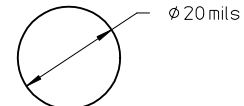

TYPE2-Peripheral Pads(Oblong-shape pada are recommended)

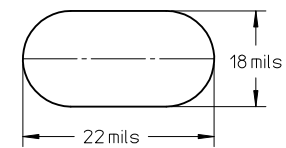

TYPE3-All Other Location Except for those of Type1 and Type2 Locations)

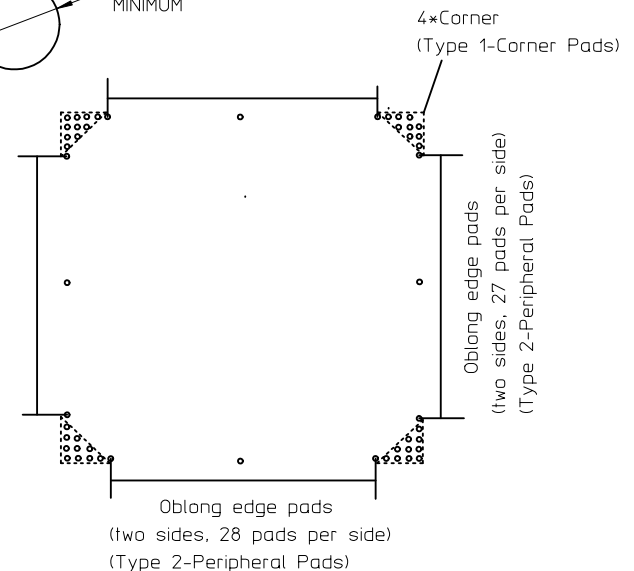
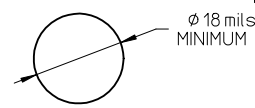

MOTHERBOARD KEEP IN ZONE (KIZ)  
(FOR 180° ROTATION)

REVISED EC NO: SH2011-0076 DRWN:ZYXAN CHKD: APPR:AYIN	QUALITY SYMBOLS $\nabla = 0$ $\nabla = 0$ $\nabla = 0$	GENERAL TOLERANCES (UNLESS SPECIFIED)		DIMENSION STYLE MM ONLY		SCALE 2:1	DESIGN UNITS METRIC	THIRD ANGLE PROJECTION			
		4 PLACES ± --- ± ---	mm INCH	DRAWN BY QWFANG	DATE 2008/04/25	TITLE RPGA989 SOCKET ASSEMBLY					
		3 PLACES ± --- ± ---		CHECKED BY JKACHLIC	DATE 2008/05/29						
		2 PLACES ± 0.10 ± ---		APPROVED BY CL IANG	DATE 2008/05/29	MOLEX INCORPORATED					
		1 PLACE ± 0.20 ± ---		MATERIAL NO. SEE TABLE		DOCUMENT NO. SD-47989-001	SHEET NO. 6 OF 6				
DRAFT WHERE APPLICABLE MUST REMAIN WITHIN DIMENSIONS				THIS DRAWING CONTAINS INFORMATION THAT IS PROPRIETARY TO MOLEX INCORPORATED AND SHOULD NOT BE USED WITHOUT WRITTEN PERMISSION							