

PRODUCT DATA DRAWING

REVISION HISTORY			
REV	DESCRIPTION	DATE	APPROVED
A	DCN 41797	10/15	DAL

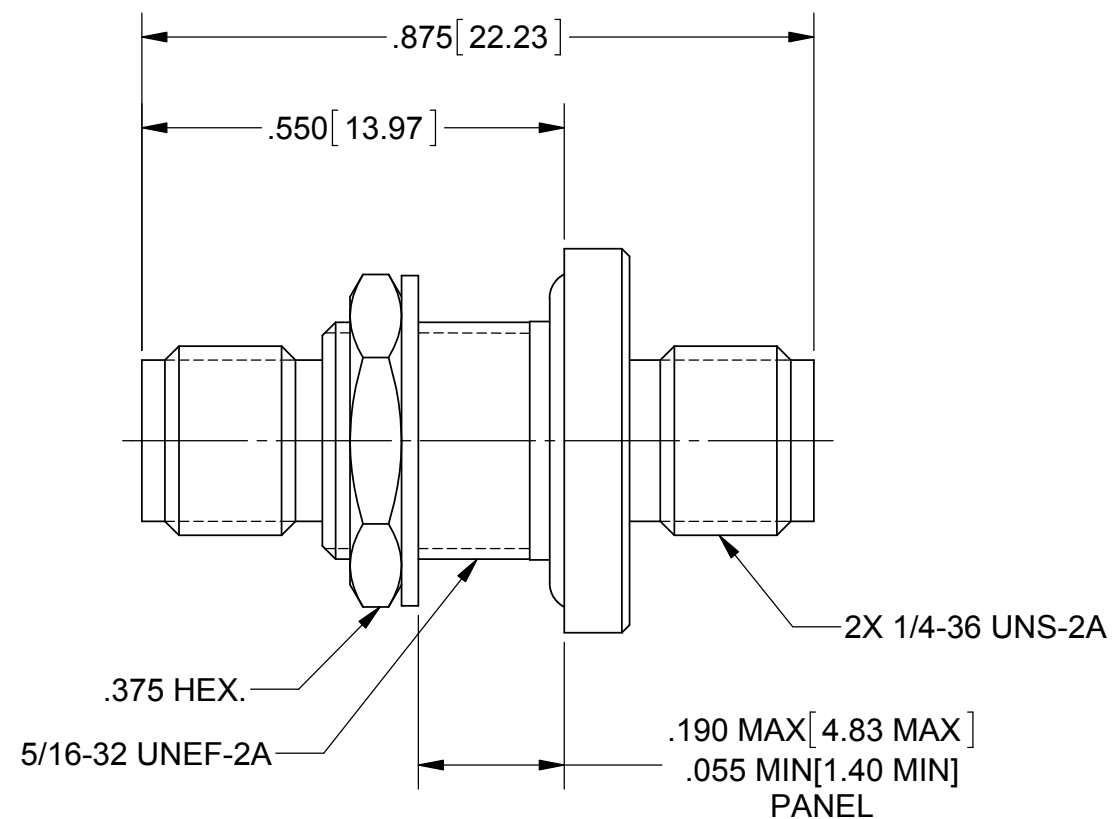
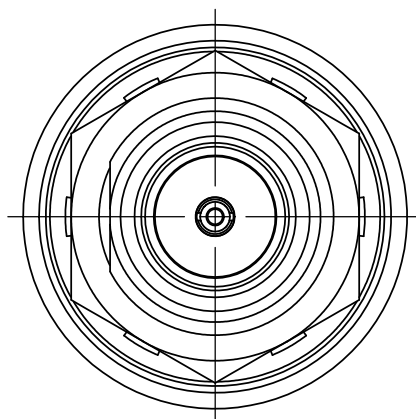
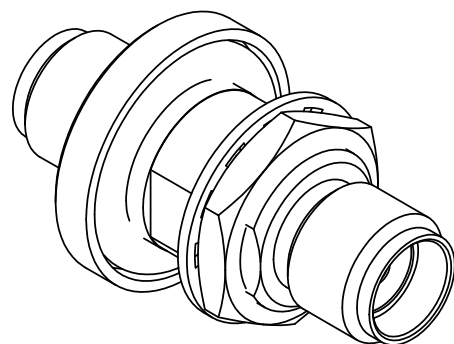

MATERIAL:

BODY & HEX NUT: STAINLESS STEEL PER AMS-5640, ALLOY UNS S30300, TYPE 1

CONTACTS: BERYLLIUM COPPER PER ASTM B196, ALLOY No. UNS C17300, TD04

INSULATORS: PTFE PER ASTM D1710, TYPE I, GRADE 1, CLASS B

O-RING: SILICONE RUBBER PER A-A-59588, CLASS 2B, GRADE 50/60

LOCKWASHER: 300 SERIES STAINLESS STEEL

GLASS: EN1 OR EQUIVALENT

PIN: KOVAR

FINISH:

BODY, HEX NUT & WASHER: PASSIVATED PER AMS-2700

CONTACTS: GOLD PER ASTM B488, TYPE II, CODE C, CLASS 0.76, OVER NICKEL PER AMS-QQ-N-290, CLASS 1, .00005" MIN.

PIN: NICKEL PER AMS-QQ-N-290, CLASS 1

PERFORMANCE:

IMPEDANCE: 50 OHMS
FREQ. RANGE: DC TO 18.0 GHz

RECOMMENDED MOUNTING HOLE

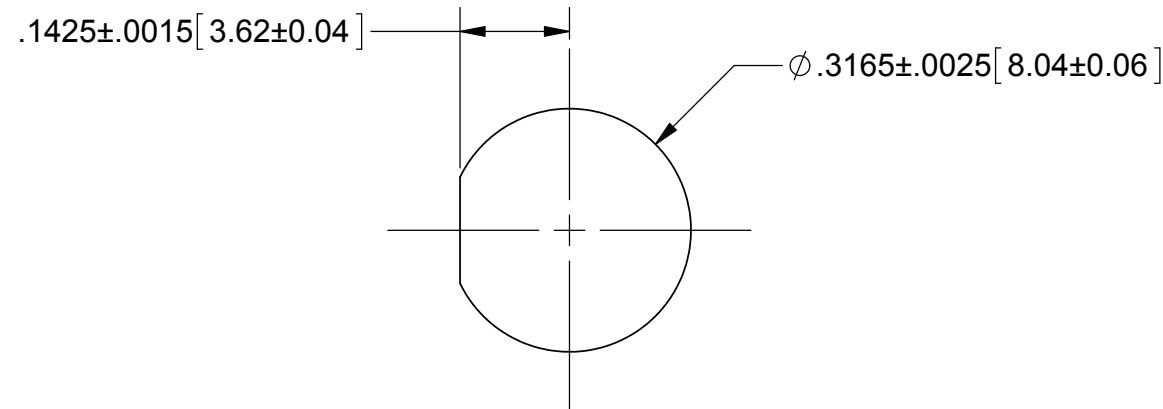

MATERIAL: SEE NOTES	DIMENSIONS ARE IN INCHES TOLERANCES: FRACTIONAL: ±1/64 ANGULAR: X° ±1'0" X"X' ±15'	UNLESS OTHERWISE SPECIFIED 1) ALL DIMENSIONS ARE IN INCHES (MILLIMETERS) 2) ALL DIMENSIONS ARE AFTER PLATING. 3) BREAK CORNERS & EDGES .005 R. MAX. 4) CHAM. 1ST & LAST THREADS. 5) SURFACE ROUGHNESS 63-MIL-STD-10. 6) DIA. 'S ON COMMON CENTERS TO BE CONCENTRIC WITHIN .005 T.I.R. 7) REMOVE ALL BURRS	SV Microwave, Inc. 2400 Centrepark West Drive, Suite 100 West Palm Beach, FL 33409 TITLE: SMA JACK TO JACK BULKHEAD ADAPTER HERMETIC SEAL SIZE: B CAGE CODE: 95077 DWG. NO.: SF2991-6002 SCALE: 4:1 SHEET 1 OF 1
FINISH: SEE NOTES	DECIMAL: X ±.030 .XX ±.010 .XXX ±.005	INTERPRET DIMENSIONS AND TOLERANCES PER ASME Y14.5M - 1994	
SURFACE AREA: N/A	THIRD ANGLE PROJECTION	DRAWN: BNK 10/29/15	
PROPRIETARY THE INFORMATION CONTAINED IN THIS DRAWING IS THE SOLE PROPERTY OF SV MICROWAVE, INC. ANY REPRODUCTION IN PART OR AS A WHOLE WITHOUT THE WRITTEN PERMISSION OF SV MICROWAVE, INC IS PROHIBITED.		CHECKED: DAL 10/29/15	
		APPROVED: DGG 02/26/79	