

THIS DRAWING IS UNPUBLISHED.

RELEASED FOR PUBLICATION

© COPYRIGHT - TE Connectivity

ALL RIGHTS RESERVED.

REVISIONS

P	LTR	DESCRIPTION	DATE	DWN	APVD
	B1	PART STATUS UPDATED	17JAN2018	RK	PS

MATERIAL:
 HOUSING: THERMOPLASTIC, UL94V-0, BLACK.
 TERMINALS: TIN PLATED COPPER ALLOY.
 QC TABS: TIN PLATED COPPER ALLOY.
 SCREWS: 6-32, ZINC PLATED STEEL.

ELECTRICAL:
 UL/CSA
 CLASS C: 20A, 300V.
 CLASS D: 5A, 600V.
 WIRE RANGE: 12-22 AWG

MECHANICAL:
 RECOMMENDED TORQUE: 7 IN-LB.
 OPERATING TEMP.: 105°C MAX

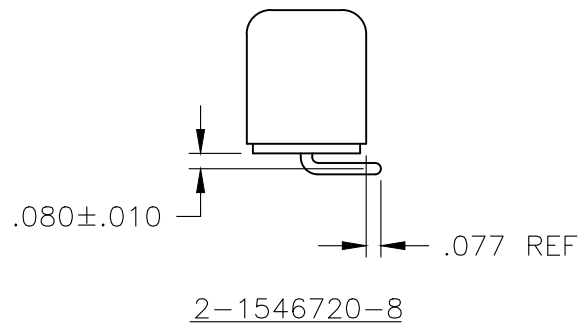
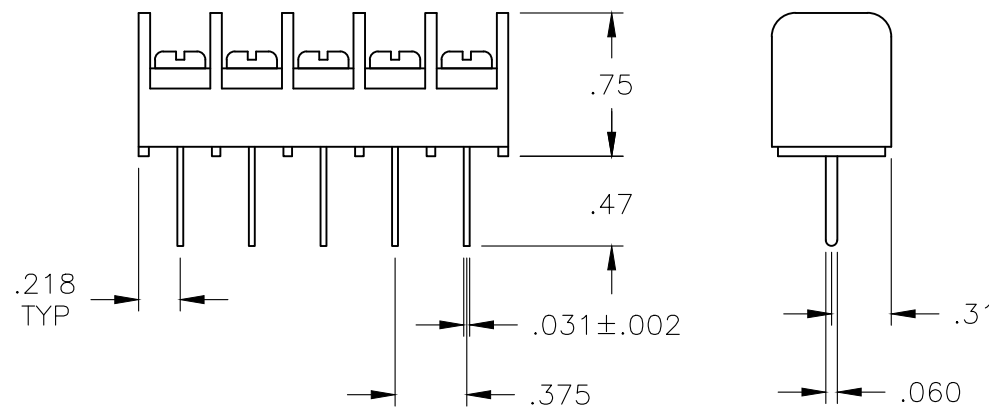
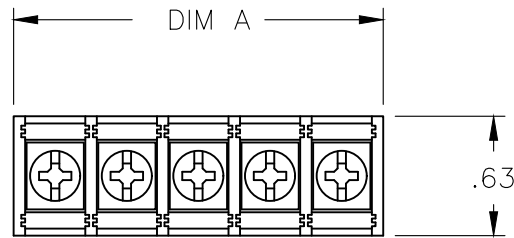

SEE FIGURE

OBSOLETE

SEE FIGURE

SEE FIGURE

	9.436	25	JC6-E107-25	2-1546720-5
	9.061	24	JC6-E107-24	2-1546720-4
	8.686	23	JC6-E107-23	2-1546720-3
	8.311	22	JC6-E107-22	2-1546720-2
	7.936	21	JC6-E107-21	2-1546720-1
	7.561	20	JC6-E107-20	2-1546720-0
	7.186	19	JC6-E107-19	1-1546720-9
	6.811	18	JC6-E107-18	1-1546720-8
	6.436	17	JC6-E107-17	1-1546720-7
	6.061	16	JC6-E107-16	1-1546720-6
	5.686	15	JC6-E107-15-182	2-1546720-7
	5.686	15	JC6-E107-15	1-1546720-5
	5.311	14	JC6-E107-14	1-1546720-4
	4.936	13	JC6-E107-13	1-1546720-3
	4.561	12	JC6-E107-12	1-1546720-2
	4.186	11	JC6-E107-11	1-1546720-1
	3.811	10	JC6-E107-10	1-1546720-0
	3.436	9	JC6-E107-09	1546720-9
	3.061	8	JC6-E107-08-242	2-1546720-9
	3.061	8	JC6-E107-08	1546720-8
	2.686	7	JC6-E107-07	1546720-7
	2.311	6	JC6-E107-06	1546720-6
	1.936	5	JC6-E107-05	1546720-5
	1.561	4	JC6-E107-04	1546720-4
	1.186	3	JC6-E107-03-221	2-1546720-8
	1.186	3	JC6-E107-03-181	2-1546720-6
	1.186	3	JC6-E107-03	1546720-3
	.811	2	JC6-E107-02	1546720-2

DIM. A REF.	NO. OF POS.	CATALOG NUMBER	TE PART NO.
-------------	-------------	----------------	-------------

THIS DRAWING IS A CONTROLLED DOCUMENT.

DIMENSIONS: INCHES

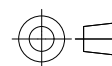

TOLERANCES UNLESS OTHERWISE SPECIFIED:

0 PLC	± -
1 PLC	± -
2 PLC	± .01
3 PLC	± .005
4 PLC	± -
ANGLES	± -

MATERIAL

FINISH

DWN 12/8/04

S SCHLEGEL

CHK 12/8/04

S. YODER

APVD 12/8/04

S. YODER

PRODUCT SPEC

APPLICATION SPEC

WEIGHT

CUSTOMER DRAWING

STE TE Connectivity

NAME
 JC6-E107-XX ASSEMBLY

SIZE	CAGE CODE	DRAWING NO	RESTRICTED TO
A3	00779	C-1546720	-

SCALE	SHEET	REV
NTS	1 OF 1	B1