

SCA3300

Data Sheet

SCA3300-D01 3-axis industrial accelerometer with digital SPI interface

Features

- 3-axis (XYZ) accelerometer
- User selectable measurement modes:
 $\pm 1.5g$, $\pm 3g$, $\pm 6g$ with 70 Hz LPF
 $\pm 1.5g$ with 10 Hz LPF
- $-40^{\circ}\text{C} \dots +125^{\circ}\text{C}$ operating range
- 3.0V...3.6V supply voltage
- SPI digital interface
- Extensive self-diagnostics features
- Ultra-low $37 \mu\text{g}/\sqrt{\text{Hz}}$ noise density
- Excellent offset stability
- Size 8.6 x 7.6 x 3.3 mm (l x w x h)
- RoHS compliant robust DFL plastic package suitable for lead free soldering process and SMD mounting
- Proven capacitive 3D-MEMS technology



Applications

SCA3300-D01 is targeted at applications demanding high stability with tough environmental requirements.

Typical applications include:

- Leveling
- Angle measurement
- Tilt Compensation
- Inertial Measurement Units (IMUs)
- Motion analysis and control
- Navigation systems

Overview

The SCA3300-D01 is a high performance accelerometer sensor component. It is a three-axis accelerometer sensor based on Murata's proven capacitive 3D-MEMS technology. Signal processing is done in mixed signal ASIC with flexible SPI digital interface. Sensor element and ASIC are packaged into 12 pin pre-molded plastic housing that guarantees reliable operation over product's lifetime.

The SCA3300-D01 is designed, manufactured and tested for high stability, reliability and quality requirements. The component has extremely stable output over wide range of temperature and vibration. The component has several advanced self-diagnostics features, is suitable for SMD mounting and is compatible with RoHS and ELV directives.

TABLE OF CONTENTS

1	Introduction.....	4
2	Specifications	4
2.1	Abbreviations	4
2.2	General Specifications	4
2.3	Accelerometer Performance Specifications.....	5
2.4	Temperature Sensor Performance Specification.....	6
2.5	Absolute Maximum Ratings	6
2.6	Pin Description.....	7
2.7	Typical Performance Characteristics.....	8
2.8	Digital I/O Specification.....	12
2.8.1	DC Characteristics.....	12
2.8.2	SPI AC Characteristics	13
2.9	Measurement Axis and Directions.....	14
2.10	Package Characteristics	15
2.10.1	Package Outline Drawing	15
2.11	PCB Footprint	16
3	General Product Description.....	16
3.1	Factory Calibration.....	17
4	Component Operation and Reset	17
4.1	Component Operation.....	17
4.2	Start-up Sequence	18
4.3	Operation Modes	19
5	Component Interfacing.....	19
5.1.1	General.....	19
5.1.2	Protocol	19
5.1.3	SPI Frame	20
5.1.4	Operations.....	21
5.1.5	Return Status.....	22
5.2	Checksum (CRC).....	22
6	Register Definition	24
6.1	Sensor Data Block	25
6.1.1	Example of Acceleration Data Conversion	25
6.1.2	Example of Temperature Data Conversion	26
6.2	STO.....	27
6.2.1	Example of Self-Test Analysis	28
6.3	STATUS	28
6.3.1	Example of STATUS summary reset	30

6.4	CMD	30
6.5	WHOAMI	31
6.6	Serial Block.....	32
6.6.1	Example of Resolving Serial Number.....	33
6.7	SELBANK	33
7	Application Information.....	34
7.1	Application Circuitry and External Component Characteristics.....	34
7.2	Assembly Instructions	36
8	Frequently Asked Questions.....	36
9	Order Information	37

1 Introduction

This document contains essential technical information about the SCA3300-D01 sensor including specifications, SPI interface descriptions, user accessible register details, electrical properties and application information. This document should be used as a reference when designing in SCA3300-D01 component.

2 Specifications

2.1 Abbreviations

ASIC	Application Specific Integrated Circuit
SPI	Serial Peripheral Interface
RT	Room Temperature, +23 °C
FS	Full Scale
CSB	Chip Select
SCK	Serial Clock
MOSI	Master Out Slave In
MISO	Master In Slave Out
MCU	Microcontroller
STO	Self-test Output
EMI	Electromagnetic Interference
ODR	Output Data Rate

2.2 General Specifications

General specifications for SCA3300-D01 component are presented in Table 1. All analog voltages are related to the potential at AVSS and all digital voltages are related to the potential at DVSS.

Table 1 General specifications

Parameter	Condition	Min	Nom	Max	Units
Supply voltage: VDD		3.0	3.3	3.6	V
SPI supply voltage: DVIO	Must never be higher than VDD	3.0	3.3	3.6	V
Current consumption: I_VDD	Temperature range -40 ... +125 °C Standard operation		1.2		mA

2.3 Accelerometer Performance Specifications

Table 2 Accelerometer performance specifications. Supply voltage VDD = 3.3 V and room temperature (RT) +23 °C unless otherwise specified. Definition of gravitational acceleration: $g = 9.819 \text{ m/s}^2$

Parameter	Condition	Min	Nom	Max	Unit
Measurement range	Measurement axes XYZ	-6		6	g
Offset (zero acceleration output)			0		LSB
Offset error ^(A)	-40°C ... +125°C	-20 -1.15		+20 +1.15	mg °
Offset temperature dependency ^(B)	-40°C ... +125°C X and Y axes	-10 -0.57		+10 +0.57	mg °
	-40°C ... +125°C Z axis	-15 -0.86		+15 +0.86	mg °
Sensitivity	±3g Mode 1 ±6g Mode 2 ±1.5g Mode 3 and Mode 4		2700 1350 5400		LSB/g
Sensitivity error ^(A)	-40°C ... +125°C Mode 1 (±3g 70 Hz)	-0.7		+0.7	%
Sensitivity temperature dependency ^(B)	-40°C ... +125°C Mode 1 (±3g 70 Hz)	-0.3		+0.3	%
Linearity error ^(C)	-1g ... +1g range	-1		+1	mg
	-6g ... +6g range	-15		+15	mg
Integrated noise (RMS) ^(E)	Mode 1		0.44		mg _{RMS}
Noise density ^(E)	Mode 1		37		μg/√Hz
Cross axis sensitivity ^(D)	per axis, Mode 1	-1		+1	%
Amplitude response, -3dB frequency	Mode 1, 2, 3		70		Hz
	Mode 4		10		Hz
Power on start-up time ^(F)			1		ms
Output settling time	Mode 1, 2, 3		15		ms
	Mode 4		100		ms
ODR			2000		Hz

Min and Max values are validation ±3 sigma variation limits from test population at the minimum. Min and Max values are not guaranteed. Nominal values are mean values from validation test population.

- A) Includes calibration error, temperature, supply voltage and drift over lifetime.
- B) Deviation from value at room temperature (RT).
- C) Straight line through specified measurement range end points.
- D) Cross axis sensitivity is the effect of a signal from orthogonal axes to the measured axis.
- E) SPI communication and EMI may affect the noise level. Used SPI clock and EMI conditions should be carefully validated. Recommended SPI clock is 2 MHz - 4 MHz to achieve the best performance; see section 2.8.2 SPI AC Characteristics for details.
- F) Power on start-up time does not include output settling time

2.4 Temperature Sensor Performance Specification

Table 3 Temperature sensor performance specifications

Parameter	Condition	Min.	Typ	Max.	Unit
Temperature signal range		-50		+150	°C
Temperature signal sensitivity	Direct 16-bit word		18.9		LSB/°C
Temperature signal offset	°C output	-10		10	°C

Temperature is converted to °C with following equation:

$$\text{Temperature [}^\circ\text{C]} = -273 + (\text{TEMP} / 18.9),$$

where TEMP is temperature sensor output register content in decimal format.

2.5 Absolute Maximum Ratings

Within the maximum ratings (Table 4), no damage to the component shall occur. Parametric values may deviate from specification, yet no functional failure shall occur.

Table 4 Absolute maximum ratings

Symbol	Description	Min.	Typ	Max.	Unit
VDD	Supply voltage analog circuitry	-0.3		4.3	V
DIN/DOUT	Maximum voltage at digital input and output pins	-0.3		DVIO+0.3	V
Topr	Operating temperature range	-40		+125	°C
Tstg	Storage temperature range	-40		+150	°C
ESD_HBM	ESD according Human Body Model (HBM) Q100-002	-2000		2000	V
ESD_CDM	ESD according Charged Device Model (CDM) Q100-011	-1000		1000	V
US	Ultrasonic agitation (cleaning, welding, etc.)	Prohibited			

2.6 Pin Description

The pinout for SCA3300-D01 is presented in Figure 1.

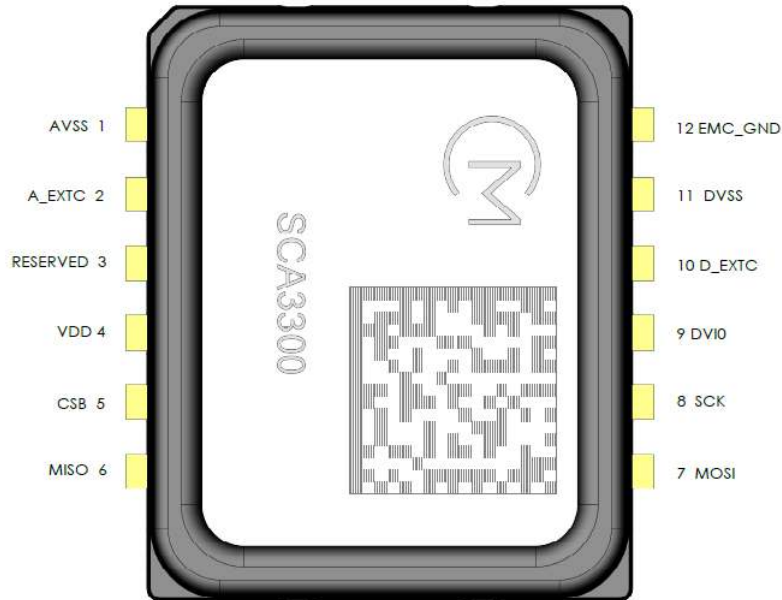

Figure 1 Pinout for SCA3300-D01

Table 5 SCA3300-D01 pin descriptions

Pin#	Name	Type	Description
1	AVSS	GND	Analog reference ground, connect externally to GND
2	A_EXTC	AOUT	External capacitor connection for analog core
3	RESERVED	-	Factory use only, connect externally to GND
4	VDD	SUPPLY	Analog Supply voltage
5	CSB	DIN	Chip Select of SPI Interface, 3.3V logic compatible Schmitt-trigger input
6	MISO	DOUT	Data Out of SPI Interface
7	MOSI	DIN	Data In of SPI Interface, 3.3V logic compatible Schmitt-trigger input
8	SCK	DIN	CLK signal of SPI Interface
9	DVIO	SUPPLY	SPI interface Supply Voltage
10	D_EXTC	AOUT	External capacitor connection for digital core
11	DVSS	GND	Digital reference ground, connect externally to GND. Must never be left floating when component is powered.
12	EMC_GND	EMC GND	EMC ground pin, connect externally to GND

2.7 Typical Performance Characteristics

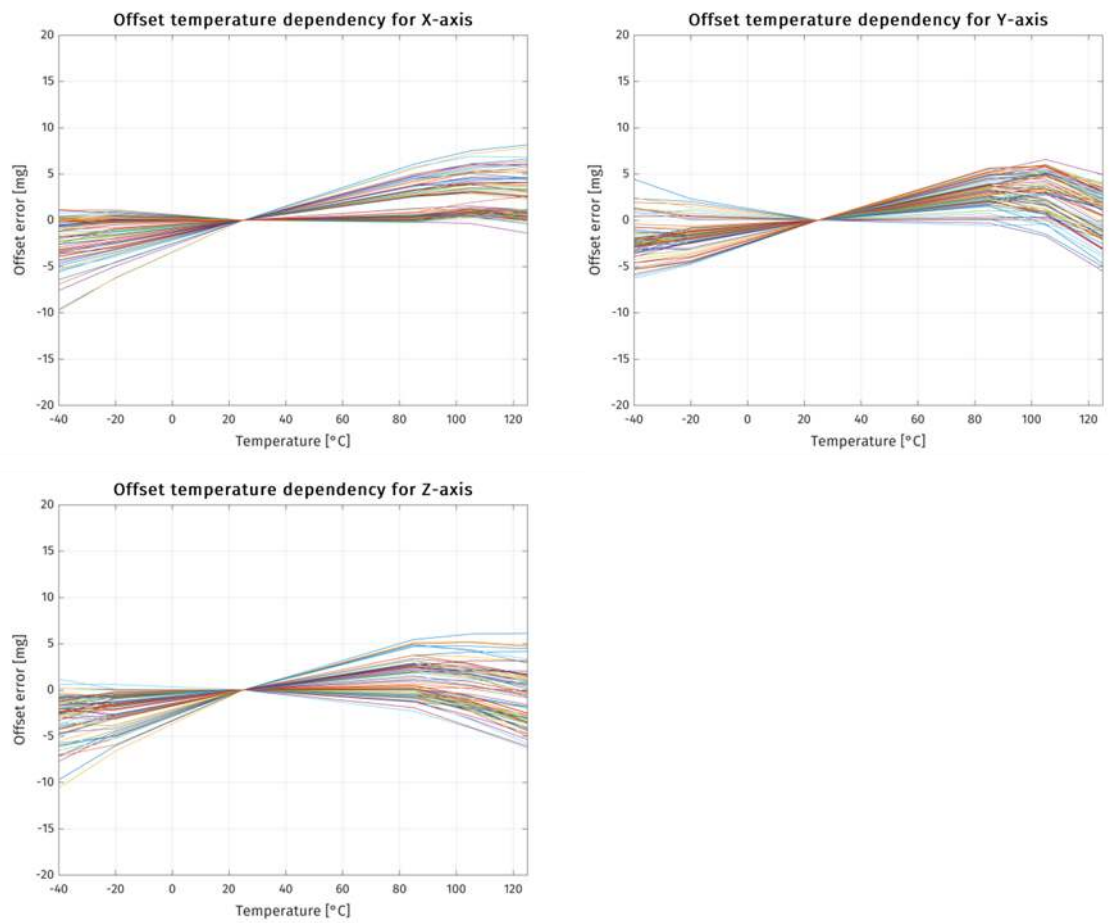

Figure 2 Accelerometer typical offset temperature behavior

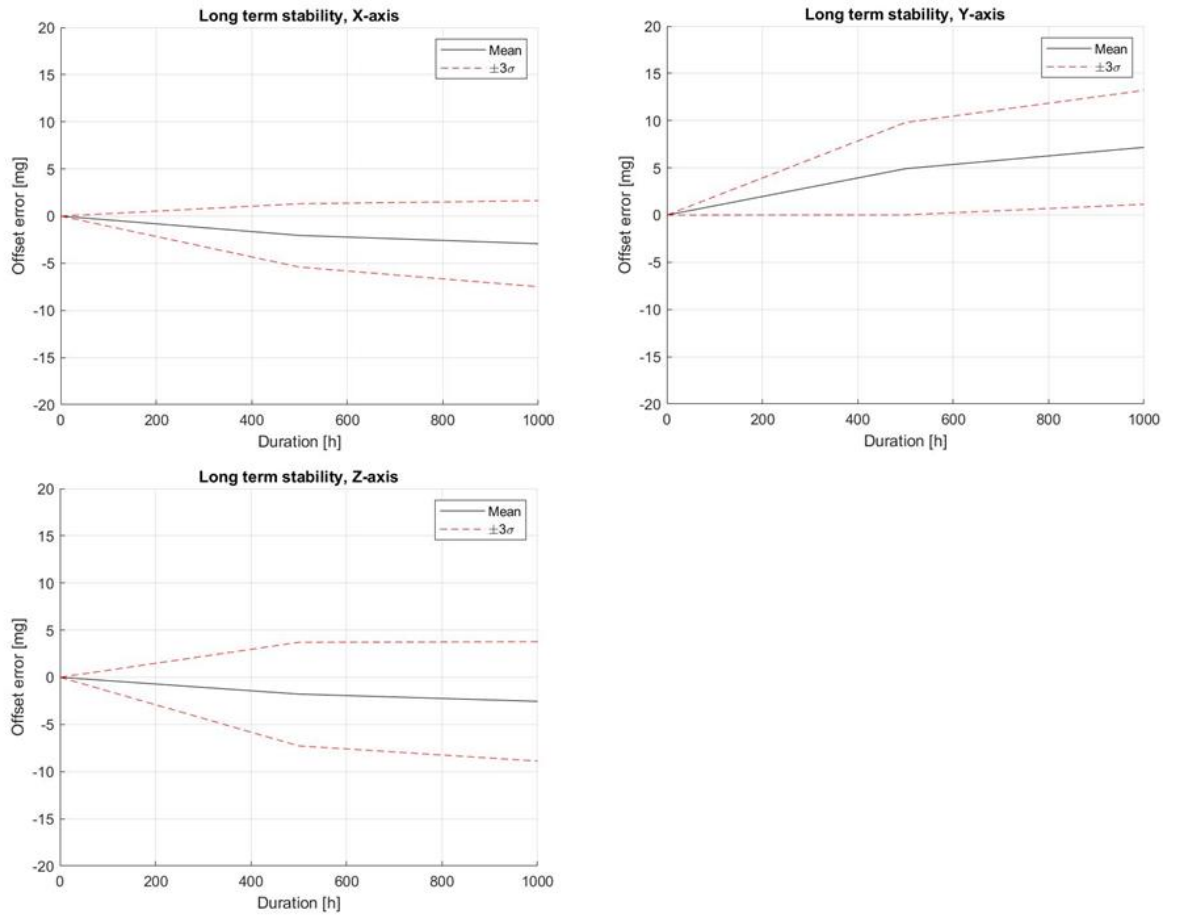

Figure 3 Example of accelerometer long term stability during 1000h HTOL.
Test condition = +125 °C, Vsupply=3.6 V. Data measurement condition = +25 °C.

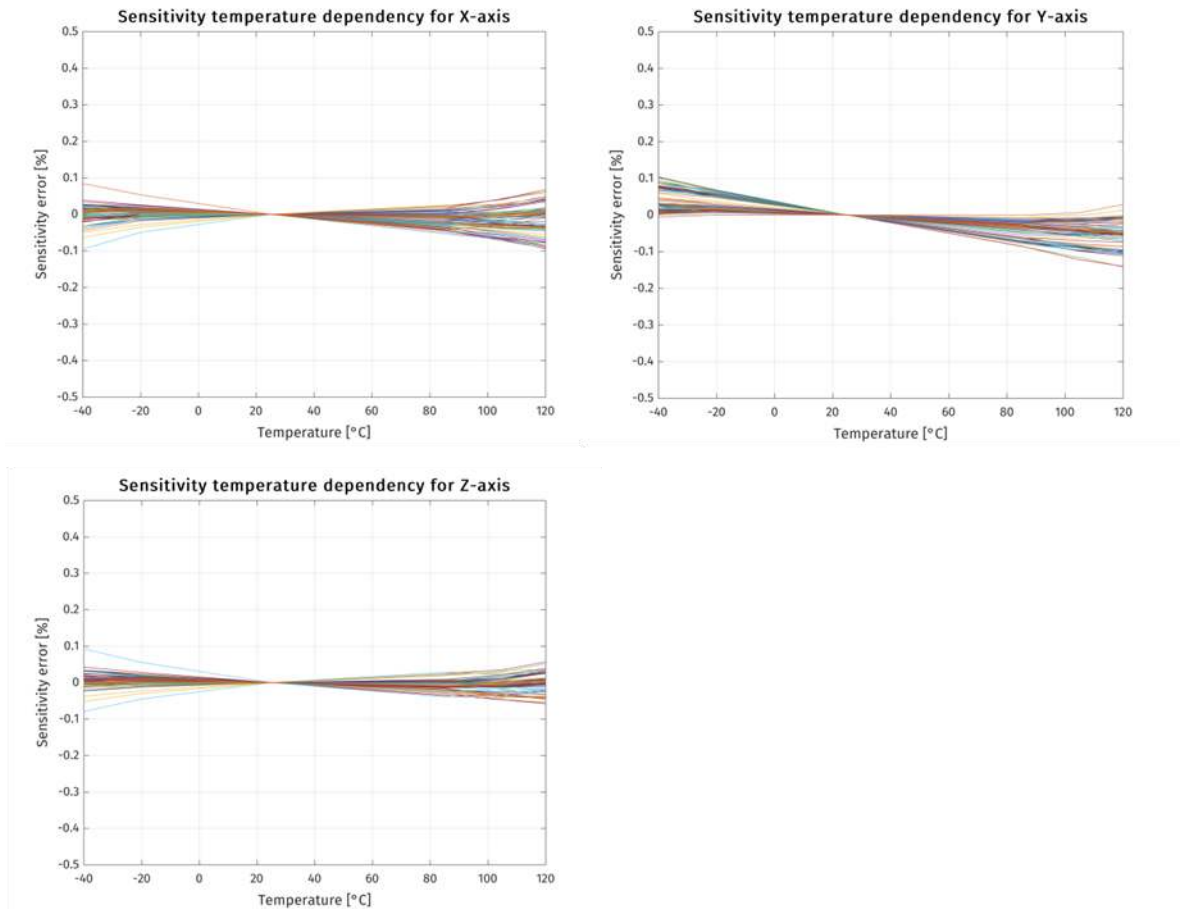

Figure 4 Accelerometer typical sensitivity temperature error in %

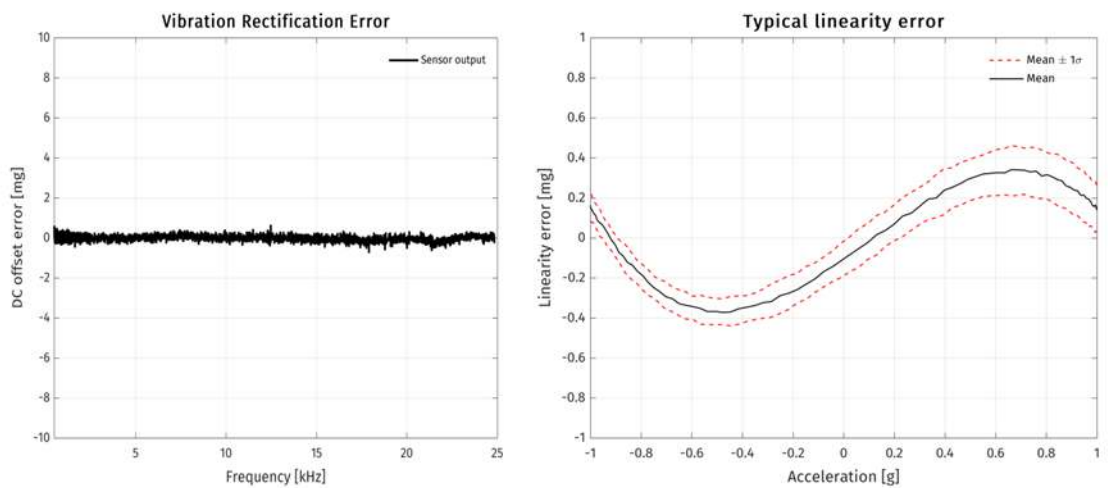

Figure 5 Left: Vibration rectification error; Sine sweep 500...5 KHz with 4 g amplitude and 5 kHz...25 kHz with 2 g amplitude. Right: Accelerometer typical linearity behavior

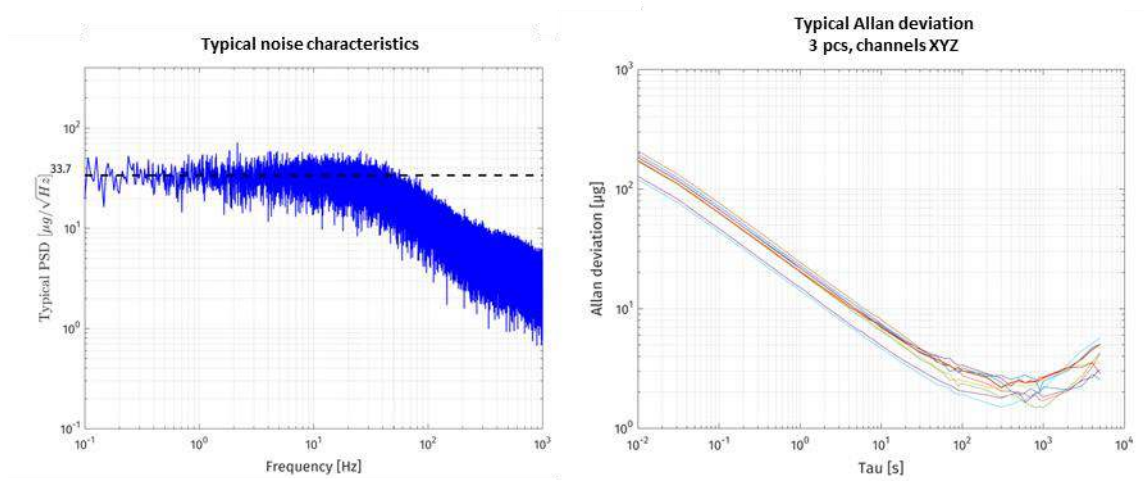

Figure 6 Left: Accelerometer typical noise density. Right: Typical Allan deviation

2.8 Digital I/O Specification

2.8.1 DC Characteristics

Table 6 describes the DC characteristics of SCA3300-D01 sensor SPI I/O pins. Supply voltage is 3.3 V unless otherwise specified. Current flowing into the circuit has a positive value.

Table 6 SPI DC Characteristics

Symbol	Remark	Min.	Typ	Max.	Unit	
Serial Clock SCK (Pull Down)						
I_{PD}	Pull-down current	$V_{in} = 3.0 - 3.6 V$	7.5	16.5	36	μA
V_{IH}	Input voltage '1'		$0.67 \cdot DVIO$		$DVIO$	V
V_{IL}	Input voltage '0'		0		$0.33 \cdot DVIO$	V
Chip Select CSB (Pull Up), low active						
I_{PU}	Pull-up current	$V_{in} = 0$	7.5	16.5	36	μA
V_{IH}	Input voltage '1'		$0.67 \cdot DVIO$		$DVIO$	V
V_{IL}	Input voltage '0'		0		$0.33 \cdot DVIO$	V
Serial Data Input MOSI (Pull Down)						
I_{PD}	Pull-down current	$V_{in} = 3.0 - 3.6 V$	7.5	16.5	36	μA
V_{IH}	Input voltage '1'		$0.67 \cdot DVIO$		$DVIO$	V
V_{IL}	Input voltage '0'		0		$0.33 \cdot DVIO$	V
Serial Data Output MISO (Tri State)						
V_{OH}	Output high voltage	$I > -1 mA$	$DVIO - 0.5V$			V
V_{OL}	Output low voltage	$I < 1 mA$			0.5	V
I_{LEAK}	Tri-state leakage	$0 < V_{MISO} < 3.3 V$	-1	0	1	μA
	Maximum Capacitive load				50	pF

2.8.2 SPI AC Characteristics

The AC characteristics of SCA3300-D01 are defined in Figure 7 and Table 7.

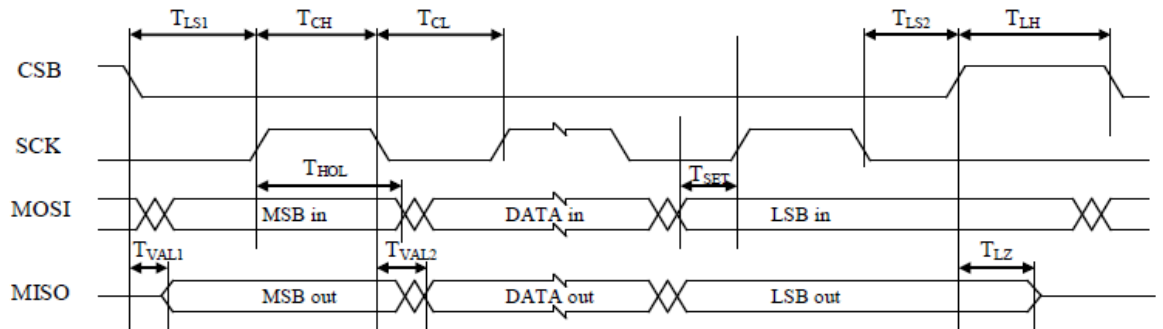

Figure 7 Timing diagram of SPI communication

Table 7 SPI AC electrical characteristics

Symbol	Description	Min.	Typ	Max.	Unit
T_{LS1}	Time from CSB (10%) to SCK (90%)	$T_{per}/2$			ns
T_{LS2}	Time from SCK (10%) to CSB (90%)	$T_{per}/2$			ns
T_{CL}	SCK low time	$T_{per}/2$			ns
T_{CH}	SCK high time	$T_{per}/2$			ns
$f_{SCK} = 1/T_{per}$	SCK Frequency *	0.1	2	8	MHz
T_{SET}	Time from changing MOSI (10%, 90%) to SCK (50%). Data setup time	$T_{per}/4$			ns
T_{HOL}	Time from SCK (50%) to changing MOSI (10%, 90%). Data hold time	$T_{per}/4$			ns
T_{VAL1}	Time from CSB (50%) to stable MISO (10%, 90%)		10		ns
T_{LZ}	Time from CSB (50%) to high impedance state of MISO		10		ns
T_{VAL2}	Time from SCK (50%) to stable MISO (10%, 90%)		10		ns
T_{LH}	Time between SPI cycles, CSB at high level (90%)	10			us

* SPI communication may affect the noise level. Used SPI clock should be carefully validated. Recommended SPI clock is 2 MHz - 4 MHz to achieve the best performance.

2.9 Measurement Axis and Directions

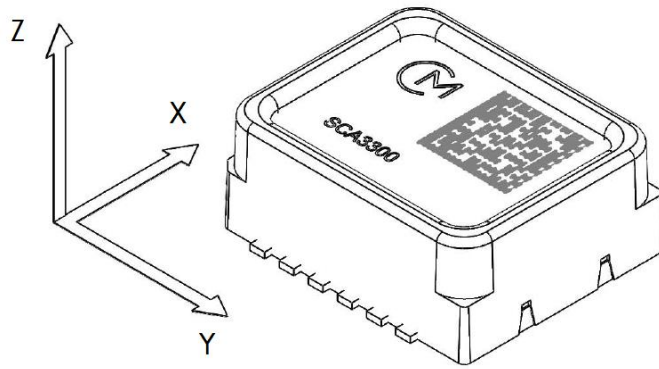







Figure 8 SCA3300-D01 measurement directions

Table 8 SCA3300-D01 accelerometer measurement directions

 <p>x: +1g y: 0g z: 0g</p>	 <p>x: 0g y: +1g z: 0g</p>	 <p>x: 0g y: 0g z: +1g</p>
 <p>x: -1g y: 0g z: 0g</p>	 <p>x: 0g y: -1g z: 0g</p>	 <p>x: 0g y: 0g z: -1g</p>

2.10 Package Characteristics

2.10.1 Package Outline Drawing

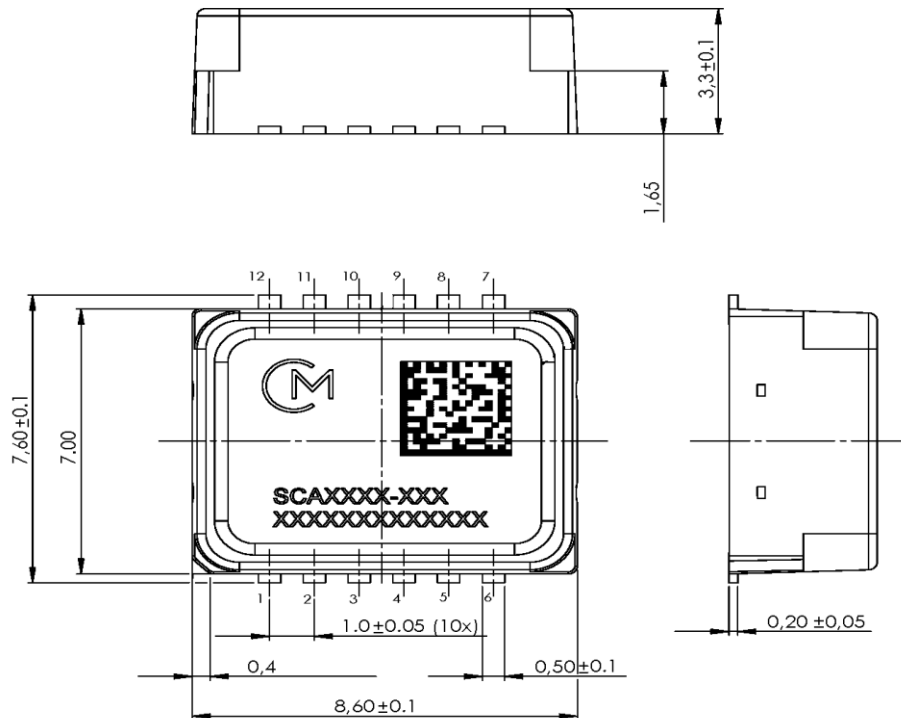

Figure 9 Package outline. The tolerances are according to ISO2768-f (see Table 9)

Table 9 Limits for linear measures (ISO2768-f)

Tolerance class	Limits in mm for nominal size in mm		
	0.5 to 3	Above 3 to 6	Above 6 to 30
f (fine)	± 0.05	± 0.05	± 0.1

2.11 PCB Footprint

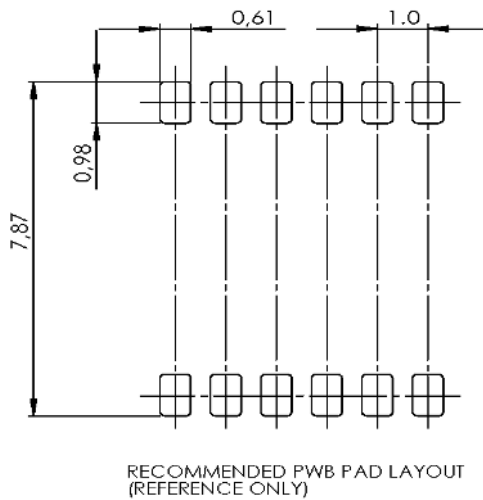

Figure 10 Recommended PWB pad layout for SCA3300-D01. All dimensions are in mm. The tolerances are according to ISO2768-f (see Table 9)

3 General Product Description

The SCA3300-D01 sensor includes acceleration sensing element and Application-Specific Integrated Circuit (ASIC). Figure 11 contains an upper level block diagram of the component.

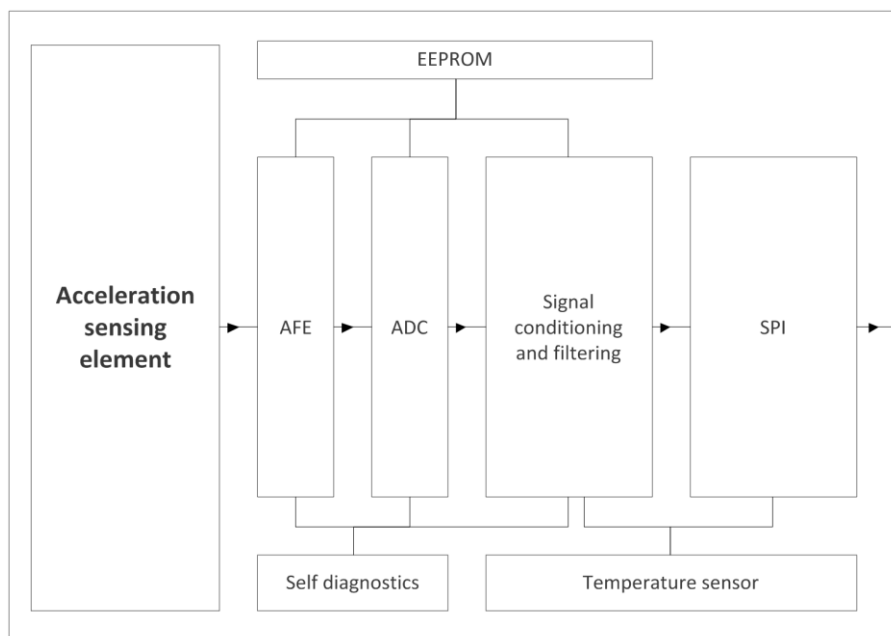

Figure 11 SCA3300-D01 component block diagram

The sensing elements are manufactured using Murata proprietary High Aspect Ratio (HAR) 3D-MEMS process, which enables making robust, extremely stable and low noise capacitive sensors.

The acceleration sensing element consists of four acceleration sensitive masses. Acceleration causes capacitance change that is converted into a voltage change in the signal conditioning ASIC.

3.1 Factory Calibration

SCA3300-D01 sensors are factory calibrated. No separate calibration is required in the application. Calibration parameters are stored to non-volatile memory during manufacturing. The parameters are read automatically from the internal non-volatile memory during the start-up.

Assembly can cause offset/bias errors to the sensor output. If best possible accuracy is required, system level offset/bias calibration (zeroing) after assembly is recommended. Offset calibration is recommended to be performed not earlier than 12 hours after reflow. It should be noted that accuracy can be improved with longer stabilization time.

4 Component Operation and Reset

4.1 Component Operation

Sensor ODR in normal operation mode is 2000 Hz. Registers are updated in every 0.5 ms and if all data is not read the full noise performance of sensor is not met.

In order to achieve optimal performance, it is recommended that during normal operation acceleration outputs ACCX, ACCY, ACCZ are read in every cycle using sensor ODR. It is necessary to read STATUS register only if return status (RS) indicates error.

4.2 Start-up Sequence

Table 10 Start-Up Sequence

Step	Procedure	RS*	Function	Note								
1	Set VDD 3.0 - 3.6 V DVIO 3.0 - 3.6 V	--	Startup the device	VDD and DVIO don't need to rise at the same time, but DVIO must never be higher than VDD Supply voltages must be settled until proceeding to the next step								
2	Write SW Reset command	--	Software reset the device	See Table 14 Operations and their equivalent SPI frames								
3	Wait 1 ms	--	Memory reading Settling of signal path									
4	Set Measurement mode**	'11'	Select operation mode	<table border="0"> <tr> <td>Mode1 (default)</td> <td>3g full-scale 70 Hz 1st order low pass filter</td> </tr> <tr> <td>Mode2</td> <td>6g full-scale 70 Hz 1st order low pass filter</td> </tr> <tr> <td>Mode3</td> <td>1.5g full-scale 70 Hz 1st order low pass filter</td> </tr> <tr> <td>Mode4</td> <td>1.5g full-scale 10 Hz 1st order low pass filter.</td> </tr> </table>	Mode1 (default)	3g full-scale 70 Hz 1st order low pass filter	Mode2	6g full-scale 70 Hz 1st order low pass filter	Mode3	1.5g full-scale 70 Hz 1st order low pass filter	Mode4	1.5g full-scale 10 Hz 1st order low pass filter.
Mode1 (default)	3g full-scale 70 Hz 1st order low pass filter											
Mode2	6g full-scale 70 Hz 1st order low pass filter											
Mode3	1.5g full-scale 70 Hz 1st order low pass filter											
Mode4	1.5g full-scale 10 Hz 1st order low pass filter.											
5	Wait 15 ms	--	Settling of signal path, Mode 1, 2, and 3									
	OR Wait 100 ms	--	Settling of signal path, Mode 4									
6	Read STATUS	'11'	Clear status summary	Reset status summary								
7	Read STATUS	'11'	Read status summary	SPI response to step 5 Read status summary. Due to SPI off-frame protocol response is before STATUS has been cleared.								
8	Read STATUS (or any other valid SPI command)	'01'	Ensure successful start-up	SPI response to step 6. First response where STATUS has been cleared. RS bits should be '01' to indicate proper start-up. Otherwise start-up has not been done correctly. See 6.3 STATUS for more information.								

* RS bits in returned SPI response during normal start-up. See 5.1.5 Return Status for more information.

** if not set, mode1 is used.

4.3 Operation Modes

SCA3300-D01 provides four user selectable operation modes. Default operation mode is mode 1: ± 3 g full-scale with 70 Hz 1st order low pass filter. After power-off, reset (SW or HW) or unintentional power-off, operation mode will be set to mode1. Current operation mode can be read with “read CMD” SPI command, see sections 5.1.4 Operations and 6.4 CMD.

Table 11 Operation mode description

Mode	Full-scale	Sensitivity LSB/g	1 st order low pass filter
1	± 3 g	2700	70 Hz
2	± 6 g	1350	70 Hz
3	± 1.5 g	5400	70 Hz
4	± 1.5 g	5400	10 Hz

5 Component Interfacing

5.1.1 General

SPI communication transfers data between the SPI master and registers of the SCA3300-D01 ASIC. The SCA3300-D01 always operates as a slave device in master-slave operation mode. 3-wire SPI connection is not supported.

Table 12 SPI interface pins

Pin	Pin Name	Communication
CSB	Chip Select (active low)	MCU → SCA3300
SCK	Serial Clock	MCU → SCA3300
MOSI	Master Out Slave In	MCU → SCA3300
MISO	Master In Slave Out	SCA3300 → MCU

5.1.2 Protocol

The SPI is a 32-bit 4-wire slave configured bus. Off-frame protocol is used so each transfer consists of two phases. A response to the request is sent within next request frame. The response concurrent to the request contains the data requested by the previous command. The first bit in a sequence is an MSB.

The SPI transmission is always started with the falling edge of chip select, CSB. The data bits are sampled at the rising edge of the SCK signal. The data is captured on the rising edge (MOSI line) of the SCK and it is propagated on the falling edge (MISO line) of the SCK. This equals to SPI Mode 0 (CPOL = 0 and CPHA = 0).

NOTE: For sensor operation, time between consecutive SPI requests (i.e. CSB high) must be at least 10 μ s. If less than 10 μ s is used, output data will be corrupted.

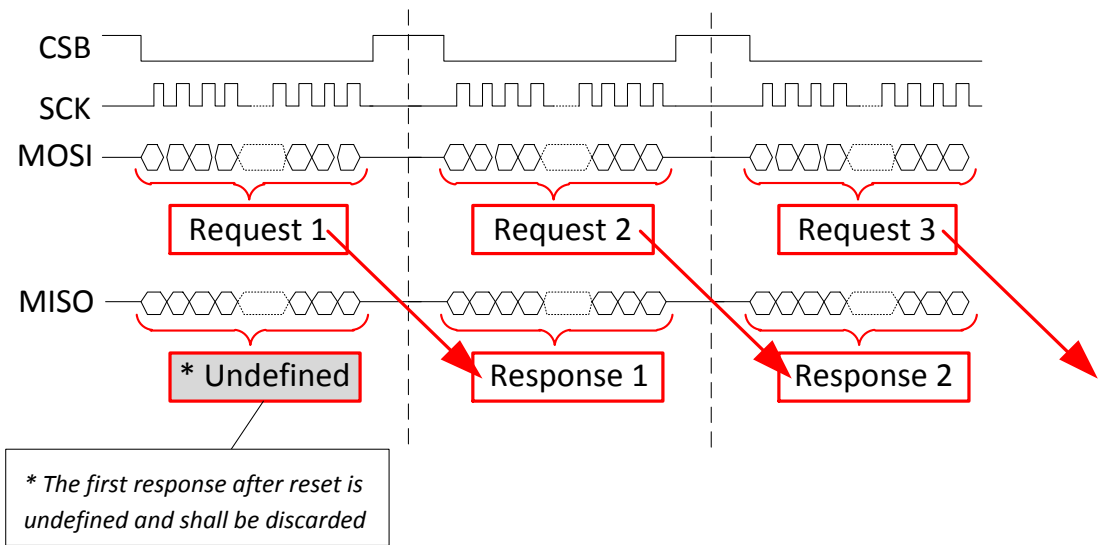

Figure 12 SPI Protocol

5.1.3 SPI Frame

The SPI Frame is divided into four parts:

1. Operation Code (OP), consisting of Read/Write (RW) and Address (ADDR)
2. Return Status (RS, in MISO)
3. Data (D)
4. Checksum (CRC)

See Figure 13 and Table 13 Table 13 SPI Frame Specification for more details. For allowed SPI operating commands see Table 14.

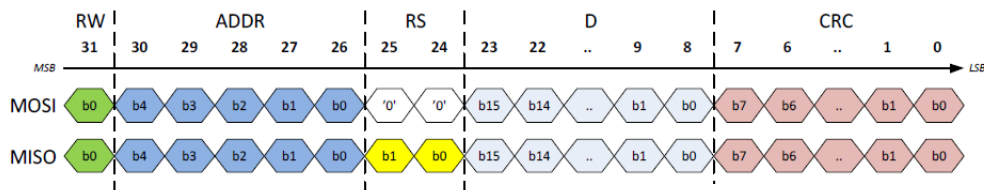

Figure 13 SPI Frame

Table 13 SPI Frame Specification

Name	Bits	Description	MISO / MOSI	
OP	[31:26]	Operation code RW + ADDR	OP [5] = RW OP [4:0] = ADDR	Read = 0 / Write = 1 Register address
RS	[25:24]	Return status	MISO '00' - Startup in progress '01' - Normal operation, no flags '10' - (Not in use) '11' - Error	MOSI '00' - Always
D	[23:8]	Data	Returned data / data to write	
CRC	[7:0]	Checksum	See section 5.2	

Return Status (RS) shows error (i.e. '11') when an error flag (or flags) is active in, or if previous MOSI-command had incorrect CRC.

5.1.4 Operations

Allowed operation commands are shown in Table 14. No other commands are allowed.

Table 14 Operations and their equivalent SPI frames

Operation	Bank	SPI Frame	SPI Frame Hex
Read ACC_X	0 1	0000 0100 0000 0000 0000 0000 1111 0111	04000F7h
Read ACC_Y	0 1	0000 1000 0000 0000 0000 0000 1111 1101	08000FDh
Read ACC_Z	0 1	0000 1100 0000 0000 0000 0000 1111 1011	0C000FBh
Read STO (self-test output)	0 1	0001 0000 0000 0000 0000 0000 1110 1001	10000E9h
Read Temperature	0 1	0001 0100 0000 0000 0000 0000 1110 1111	14000EFh
Read Status Summary	0 1	0001 1000 0000 0000 0000 0000 1110 0101	18000E5h
Read CMD	0	0011 0100 0000 0000 0000 0000 1101 1111	34000DFh
Change to mode1	0	1011 0100 0000 0000 0000 0000 0001 1111	B40001Fh
Change to mode2	0	1011 0100 0000 0000 0000 0001 0000 0010	B4000102h
Change to mode3	0	1011 0100 0000 0000 0000 0010 0010 0101	B4000225h
Change to mode4	0	1011 0100 0000 0000 0000 0011 0011 1000	B4000338h
Set power down mode	0	1011 0100 0000 0000 0000 0100 0110 1011	B400046Bh
Wake up from power down mode	0	1011 0100 0000 0000 0000 0000 0001 1111	B400001Fh
SW Reset	0	1011 0100 0000 0000 0010 0000 1001 1000	B4002098h
Read WHOAMI	0	0100 0000 0000 0000 0000 0000 1001 0001	40000091h
Read SERIAL1	1	0110 0100 0000 0000 0000 0000 1010 0111	640000A7h
Read SERIAL2	1	0110 1000 0000 0000 0000 0000 1010 1101	680000ADh
Read current bank	0 1	0111 1100 0000 0000 0000 0000 1011 0011	7C0000B3h
Switch to bank #0	0 1	1111 1100 0000 0000 0000 0000 0111 0011	FC000073h
Switch to bank #1	0 1	1111 1100 0000 0000 0000 0001 0110 1110	FC00016Eh

5.1.5 Return Status

SPI frame Return Status bits (RS bits) indicate the functional status of the sensor. See Table 15 for RS definitions.

Table 15 Return Status definitions

RS [1]	RS [0]	Description
0	0	Startup in progress
0	1	Normal operation, no flags
1	0	Reserved
1	1	Error

The priority of the return status states is from high to low: 00 → 11 → 01

Return Status (RS) shows error (i.e. '11') when an error flag (or flags) is active in Status Summary register, or if previous MOSI-command had incorrect frame CRC. See 6.3 STATUS for more information.

5.2 Checksum (CRC)

For SPI transmission error detection a Cyclic Redundancy Check (CRC) is implemented, for details see Table 16.

Table 16 SPI CRC definition

Parameter	Value
Name	CRC-8
Width	8 bit
Poly	1Dh (generator polynom: $X^8+X^4+X^3+X^2+1$)
Init	FFh (initialization value)
XOR out	FFh (inversion of CRC result)

The CRC value used in system level software has to be initialized with FFh to ensure a CRC failure in case of stuck-at-0 and stuck-at-1 error on the SPI bus. C-programming language example for CRC calculation is presented in Figure 14. It can be used as is in an appropriate programming context.

```

// Calculate CRC for 24 MSB's of the 32 bit dword
// (8 LSB's are the CRC field and are not included in CRC calculation)

uint8_t CalculateCRC(uint32_t Data)
{
    uint8_t BitIndex;
    uint8_t BitValue;
    uint8_t CRC;

    CRC = 0xFF;
    for (BitIndex = 31; BitIndex > 7; BitIndex--)
    {
        BitValue = (uint8_t)((Data >> BitIndex) & 0x01);
        CRC = CRC8(BitValue, CRC);
    }
    CRC = (uint8_t)~CRC;
    return CRC;
}

static uint8_t CRC8(uint8_t BitValue, uint8_t CRC)
{
    uint8_t Temp;

    Temp = (uint8_t)(CRC & 0x80);
    if (BitValue == 0x01)
    {
        Temp ^= 0x80;
    }
    CRC <<= 1;
    if (Temp > 0)
    {
        CRC ^= 0x1D;
    }
    return CRC;
}

```

Figure 14 C-programming language example for CRC calculation

In case of wrong CRC in MOSI write/read, RS bits “11” are set in the next SPI response, STATUS register is not changed, and write command is discarded. If CRC in MISO SPI response is incorrect, communication failure occurred.

CRC calculation example:

```

Read ACC_X register (04h)
SPI [31:8] = 040000h → CRC = F7h
SPI [7:0]  = F7h
SPI frame  = 040000F7h

```

6 Register Definition

SCA3300-D01 contains two user switchable register banks. Default register bank is #0. One should have register bank #0 always active, unless data from bank #1 is required. After reading data from bank #1 is finished, one should switch back to bank #0 to ensure no accidental read / writes in unwanted registers. See 6.7 SELBANK for more information for selecting active register bank. Table 17 shows overview of register banks and register addresses.

Table 17 Register address space overview

Addr (hex)	Read/Write	Register Bank		Description
		#0	#1	
01h	R	ACC_X	ACC_X	X-axis acceleration output in 2's complement format
02h	R	ACC_Y	ACC_Y	Y-axis acceleration output in 2's complement format
03h	R	ACC_Z	ACC_Z	Z-axis acceleration output in 2's complement format
04h	R	STO	STO	Self-test output in 2's complement format
05h	R	TEMPERATURE	TEMPERATURE	Temperature sensor output in 2's complement format
06h	R	STATUS	STATUS	Status Summary
07h	-	reserved	reserved	-
08h	-	reserved	reserved	-
09h	-	reserved	reserved	-
0Ah	-	reserved	reserved	-
0Bh	-	reserved	reserved	-
0Ch	-	reserved	reserved	-
0Dh	R / W	MODE	reserved	Sets operation mode, SW Reset and Power down mode
0Eh	-	reserved	reserved	-
0Fh	-	reserved	reserved	-
10h	R	WHOAMI	reserved	8-bit register for component identification
11h	-	reserved	reserved	-
12h	-	reserved	reserved	-
13h	-	reserved	reserved	-
14h	-	reserved	reserved	-
15h	-	reserved	reserved	-
16h	-	reserved	reserved	-
17h	-	reserved	reserved	-
18h	-	reserved	reserved	-
19h	R	reserved	SERIAL1	Component serial part 1
1Ah	R	reserved	SERIAL2	Component serial part 2
1Bh	-	reserved	Factory Use	-
1Ch	-	reserved	Factory Use	-
1Dh	-	reserved	Factory Use	-
1Eh	-	reserved	reserved	-
1Fh	R / W	SELBANK	SELBANK	Switch between active register banks

User should not access reserved registers. Power-cycle and reset will reset all written settings.

6.1 Sensor Data Block

Table 18 Sensor data block description

Addr	Name	No. of bits	Read / Write	Description
01h	ACC_X	16	R	X-axis acceleration output in 2's complement format
02h	ACC_Y	16	R	Y-axis acceleration output in 2's complement format
03h	ACC_Z	16	R	Z-axis acceleration output in 2's complement format
05h	TEMPERATURE	16	R	Temperature sensor output in 2's complement format. See section 2.4 for conversion equation.

Table 19 Sensor data block operations

Operation	SPI Frame	SPI Frame Hex
Read ACC_X	0000 0100 0000 0000 0000 0000 1111 0111	040000F7h
Read ACC_Y	0000 1000 0000 0000 0000 0000 1111 1101	080000FDh
Read ACC_Z	0000 1100 0000 0000 0000 0000 1111 1011	0C0000FBh
Read Temperature	0001 0100 0000 0000 0000 0000 1110 1111	140000EFh

6.1.1 Example of Acceleration Data Conversion

For example, if ACC_X register read results: ACC_X = 0500DC1Ch, the register content is converted to acceleration rate as follows:

OP[31:26] + RS[25:24]		Data[23:8]				CRC[7:0]	
0	5	0	0	D	C	1	C

OP + RS

05h = 0000 0101b
 0000 01b = OP code = Read ACC_X
 01b = return status (RS bits) = no error

Data = ACC_X register content

00DC1Ch
 00DC1Ch → 220d = in 2's complement format
 Acceleration:
 = 220 LSB / sensitivity(mode1)
 = 220 LSB / 2700 LSB/g
 = 0.081 g

CRC

1Ch
 CRC of 0500DC1Ch, see section 5.2

6.1.2 Example of Temperature Data Conversion

For example, if TEMPERATURE register read results: TEMPERATURE = 15161E0Ah, the register content is converted to temperature as follows:

OP[31:26] + RS[25:24]		Data[23:8]				CRC[7:0]	
1	5	1	6	1	E	0	A

OP + RS

15h = 0001 0101b

0001 01b

01b

= OP code = Read TEMP

= return status (RS bits) = no error

Data = TEMPERATURE register content

161Eh

161Eh → 5662d

= in 2's complement format

Temperature:

= -273 + (5662 / 18.9)

= +26.6°C

CRC

0Ah

CRC of 15161Eh, see section 5.2

6.2 STO

Table 20 STO (self-test output) description

Addr	Name	No. of bits	Read / Write	Description
04h	STO	16	R	Self-test output in 2's complement format

Table 21 STO operation

Operation	SPI Frame	SPI Frame Hex
Read STO (self-test output)	0001 0000 0000 0000 0000 0000 1110 1001	100000E9h

If self-test option is desired in application, following guidelines should be taken into account. STO is used to monitor if accelerometer is functioning correctly. It provides information on signal saturation during vibration and shock events. STO should be read continuously in the normal operation sequence after XYZ acceleration readings.

STO threshold monitoring should be implemented on application software. Failure thresholds and failure tolerant time of the system are application specific and should be carefully validated. Monitoring can be implemented by counting the subsequent “STO signal exceeding threshold” –events. Examples for STO thresholds are shown in Table 22.

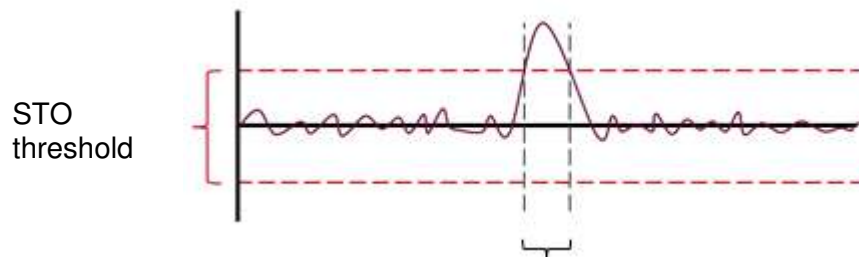

Failure-tolerant time, e.g. event counter
how many times threshold is exceeded

Component failure can be suspected if the STO signal exceeds the threshold level continuously after performing component hard reset in static (no vibration) condition.

Table 22 Examples for STO Thresholds

Mode	Full-scale	Examples for STO thresholds
1	± 3 g	±800 LSB
2	± 6 g	±400 LSB
3	± 1.5 g	±1600 LSB
4	± 1.5 g	±1600 LSB

6.2.1 Example of Self-Test Analysis

For example, if STO register read results: STO = 1100017Bh, the register value can be converted as follows:

OP[31:26] + RS[25:24]		Data[23:8]				CRC[7:0]	
1	1	0	0	0	1	7	B

OP + RS

11h = 0001 0001b
 0001 00b = OP code = Read STO
 01b = return status (RS bits) = no error

Data = STO register content

0001h
 0001h → 1d = in 2's complement format
 Self-test reading:
 = 1
 See Table 11 for recommended STO threshold values

CRC

7Bh
 CRC of 110001h, see section 5.2

6.3 STATUS

Table 23 STATUS description

Addr	Name	No. of bits	Read / Write	Description
06h	STATUS	16	R	Status Summary

Table 24 STATUS operation

Operation	SPI Frame	SPI Frame Hex
Read Status Summary	0001 1000 0000 0000 0000 0000 1110 0101	180000E5h

Table 25 STATUS register

D15	D14	D13	D12	D11	D10	D9	D8	D7	D6	D5	D4	D3	D2	D1	D0	Bit
Reserved						DIG11	DIG12	CLK	SAT	TEMP_SAT	PWR	MEM	PD	MODE_CHANGE	PIN_CONTINUITY	Read

Table 26 STATUS register bit description

Bit	Name	Description	Required action/explanation
9	DIGI1	Digital block error type 1	SW or HW reset needed
8	DIGI2	Digital block error type 2	SW or HW reset needed
7	CLK	Clock error	SW or HW reset needed
6	SAT	Signal saturated in signal path	Acceleration too high and acceleration reading not usable. Component failure possible. All acceleration and STO output data is invalid.
5	TEMP_SAT	Temperature signal path saturated	External temperature too high or low. Component failure possible
4	PWR	Start-up indication or Voltage level failure	[After star-up or reset] This flag is set high. No actions needed.
			[During normal operation] External voltages too high or low. Component failure possible. SW or HW reset needed.
3	MEM	Error in non-volatile memory	Memory check failed. Possible component failure SW or HW reset needed.
2	PD	Device in power down mode	If power down is not requested. SW or HW reset needed
1	MODE_CHANGE	Operation mode changed	Bit is set high if operation mode has been changed If mode change is not requested SW or HW reset needed
0	PIN_CONTINUITY	Component internal connection error	Possible component failure

Software (SW) reset is done with SPI operation (see 5.1.4). Hardware (HW) reset is done by power cycling the sensor. If these do not reset the error, then possible component error has occurred and system needs to be shut down and part returned to supplier.

6.3.1 Example of STATUS summary reset

STATUS summary is reset by reading it. Below is an example of MOSI commands and corresponding MISO responses for command Read STATUS summary when there is SAT bit high in STATUS summary (Data = 0x0040).

Due to off-frame protocol of SPI the first response to MOSI command is a response to earlier MOSI command and is thus not applicable in this example.

The Return Status bits show an error (b'11) even with the first MOSI command and are reset after the second command (b'01). Return Status bits are defined in Chapter 5.1.5.

#	MOSI command	MISO response	Return Status bits (RS)	Data
1	0x180000E5	<i>don't care</i>	b'11	<i>don't care</i>
2	0x180000E5	0x1b00407a	b'11	0x0040
3	0x180000E5	0x19004079	b'01	0x0040
4	0x180000E5	0x1900006a	b'01	0x0000

6.4 CMD

Table 27 CMD description

Addr	Register Name	No. of bits	Read / Write	Description
0Dh	CMD	16	R / W	Sets operation mode, SW Reset and Power down mode

Table 28 CMD operations

Command	SPI Frame	SPI Frame hex
Read CMD	0011 0100 0000 0000 0000 0000 1101 1111	340000DFh
Change to mode1	1011 0100 0000 0000 0000 0000 0001 1111	B400001Fh
Change to mode2	1011 0100 0000 0000 0000 0001 0000 0010	B4000102h
Change to mode3	1011 0100 0000 0000 0000 0010 0010 0101	B4000225h
Change to mode4	1011 0100 0000 0000 0000 0011 0011 1000	B4000338h
Set power down mode	1011 0100 0000 0000 0000 0100 0110 1011	B400046Bh
Wake up from power down mode	1011 0100 0000 0000 0000 0000 0001 1111	B400001Fh
SW Reset	1011 0100 0000 0000 0010 0000 1001 1000	B4002098h

Table 29 CMD register

D15	D14	D13	D12	D11	D10	D9	D8	D7	D6	D5	D4	D3	D2	D1	D0	Bit
Reserved								Factory use	Factory use	SW_RST	Factory use	Factory use	PD	MODE		Read

Table 30 CMD register bit description

Bit	Name	Description
15:8	Reserved	Reserved
7	Factory use	Factory use
6	Factory use	Factory use
5	SW_RST	Software (SW) Reset
4	Factory use	Factory use
3	Factory use	Factory use
2	PD	Power Down
1:0	MODE	Operation Mode

Sets operation mode of the SCA3300-D01. After power-off, reset (SW or HW) or unintentional power-off, normal start-up sequence must be followed. Note: mode will be set to default mode1.

Operation modes are described in section 4.3.

Changing mode will set Status Summary bit 1 to high. Thus RS bits will show '11' (see 5.1.5.)

Note: User must not configure other than given valid commands, otherwise power-off or reset is required.

6.5 WHOAMI

Table 31 WHOAMI description

Addr	Register Name	No. of bits	Read / Write	Description
10h	WHOAMI	8	R	8-bit register for component identification

Table 32 WHOAMI operations

Operation	SPI Frame	SPI Frame Hex
Read WHOAMI	0100 0000 0000 0000 0000 0000 1001 0001	40000091h

Table 33 WHOAMI register

D15	D14	D13	D12	D11	D10	D9	D8	D7	D6	D5	D4	D3	D2	D1	D0	Bit
								-	-	-	-	-	-	-	-	Write
Not Used [15:8]								Component ID [7:0] = 51h								Read

WHOAMI is an 8-bit register for component identification. Returned value is 51h.

Note: as returned value is fixed, this can be used to ensure SPI communication is working correctly.

6.6 Serial Block

Table 34 Serial block description

Bank	Addr	Register Name	No. of bits	Read / Write	Description
1	19h	SERIAL1	16	R	Component serial part 1
1	1Ah	SERIAL2	16	R	Component serial part 2

Table 35 Serial block operations

Operation	SPI Frame	SPI Frame Hex
Read SERIAL1	0110 0100 0000 0000 0000 0000 1010 0111	640000A7h
Read SERIAL2	0110 1000 0000 0000 0000 0000 1010 1101	680000ADh

Serial Block contains sensor serial number in two 16 bit registers in register bank #1, see 6.7 SELBANK for information how to switch register banks. The same serial number is also written on top of the sensor.

The following procedure is recommended when reading serial number:

1. Change active register bank to #1
2. Read registers 19h and 1Ah
3. Change active register back to bank #0
4. Resolve serial number:
 1. Combine result data from 1Ah[16:31] and 19h[0:15]
 2. Convert HEX to DEC
 3. Add letters "B33" to end

6.6.1 Example of Resolving Serial Number

1. Change active register bank to #1
 SPI Request SWITCH_TO_BANK_1
 Request: FC00016E
 Response: XXXXXXXX, response to previous command

2. Read registers 19h and 1Ah
 SPI Request READ_SERIAL1:
 Request: 640000A7
 Response: FD0001E1, response to switch command

 SPI Request READ_SERIAL2:
 Request: 680000AD
 Response: 65F7DA19, response to serial1, data: F7DA

3. Change active register back to bank #0
 SPI Request SWITCH_TO_BANK_0
 Request: FC000073
 Response: 693CE54F, response to serial2, data: 3CE5

4. Resolve serial number
 1. Combined Serial number: 3CE5F7DA
 2. HEX to DEC: 1021704154
 3. Add "B33": 1021704154B33

➔ Full Serial number: 1021704154B33

6.7 SELBANK

Table 36 SELBANK description

Bank	Addr	Register Name	No. of bits	Read / Write	Description
0 1	1Fh	SELBANK	16	R	Switch between active register banks

Table 37 SELBANK operations

Command	SPI Frame	SPI Frame hex
Read current bank	0111 1100 0000 0000 0000 0000 1011 0011	7C0000B3h
Switch to bank #0	1111 1100 0000 0000 0000 0000 0111 0011	FC000073h
Switch to bank #1	1111 1100 0000 0000 0000 0001 0110 1110	FC00016Eh

SELBANK is used to switch between memory banks #0 and #1. It's recommended to keep memory bank #0 selected unless register from bank #1 is required, for example, reading serial number of sensor. After using bank #1 user should switch back to bank #0.

7 Application Information

7.1 Application Circuitry and External Component Characteristics

See Figure 15 and Table 38 for specification of the external components. The PCB layout example is shown in Figure 16.

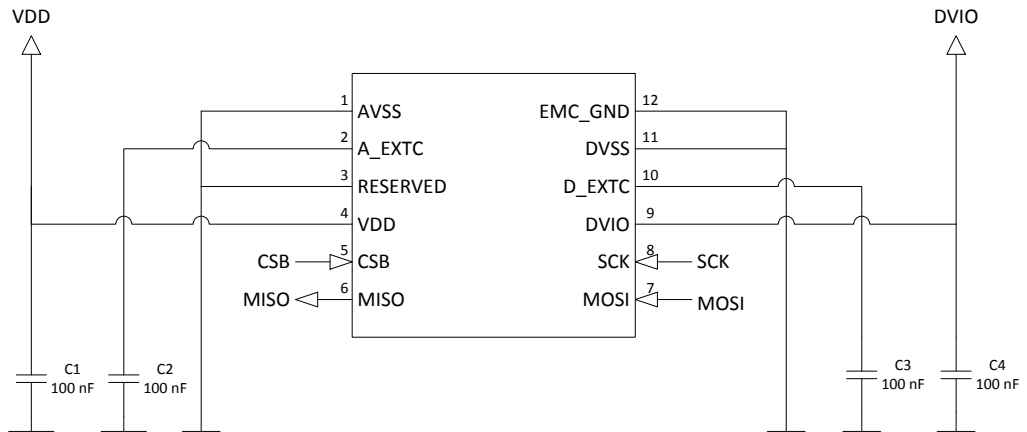

Figure 15 Application schematic

Table 38. External component description for SCA3300-D01

Symbol	Description	Min.	Nom.	Max.	Unit
C1	Decoupling capacitor between VDD and GND Recommended component: Murata GCM155R71C104KA55, 0402, 16V, X7R ESR Capacitor availability should be confirmed from www.murata.com	70	100	130 100	nF mΩ
C2	Decoupling capacitor between A_EXTC and GND Recommended component: Murata GCM155R71C104KA55, 0402, 16V, X7R ESR Capacitor availability should be confirmed from www.murata.com	70	100	130 100	nF mΩ
C3	Decoupling capacitor between D_EXTC and GND Recommended component: Murata GCM155R71C104KA55, 0402, 16V, X7R ESR Capacitor availability should be confirmed from www.murata.com	70	100	130 100	nF mΩ
C4	Decoupling capacitor between DVIO and GND Recommended component: Murata GCM155R71C104KA55, 0402, 16V, X7R ESR Capacitor availability should be confirmed from www.murata.com	70	100	130 100	nF mΩ

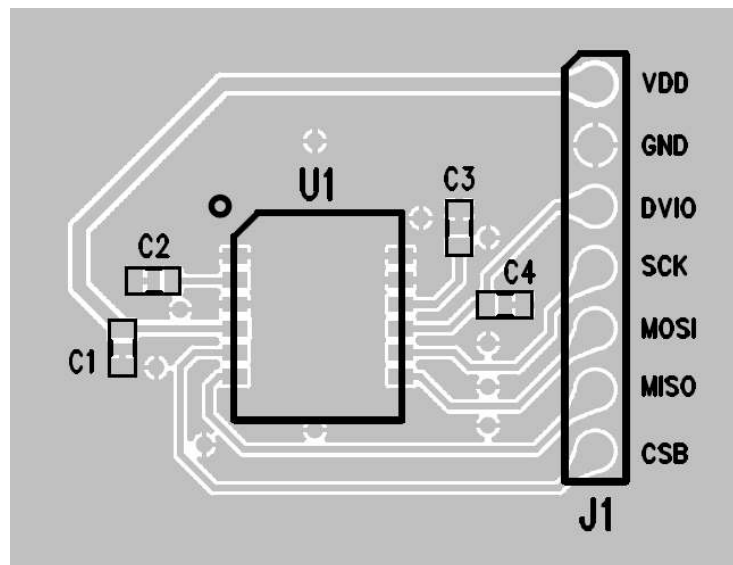

Figure 16 Application PCB layout

General circuit diagram and PCB layout recommendations for SCA3300-D01:

1. Connect decoupling SMD capacitors (C1 - C4) right next to respective component pins.
2. Place ground plate under component.
3. Do not route signals or power supplies under the component on top layer.
4. Ensure good ground connection of DVSS, AVSS, and EMC_GND pins

7.2 Assembly Instructions

The Moisture Sensitivity Level of the component is Level 3 according to the IPC/JEDEC JSTD-020C. The part is delivered in a dry pack. The manufacturing floor time (out of bag) at the customer's end is 168 hours.

Usage of PCB coating materials may penetrate component lid and affect component performance. PCB coating is not allowed.

Sensor components shall not be exposed to chemicals which are known to react with silicones, such as solvents. Sensor components shall not be exposed to chemicals with high impurity levels, such as Cl⁻, Na⁺, NO₃⁻, SO₄⁻, NH₄⁺ in excess of >10 ppm. Flame retardants such as Br or P containing materials shall be avoided in close vicinity of sensor component. Materials with high amount of volatile content should also be avoided.

If heat stabilized polymers are used in application, user should check that no iodine, or other halogen, containing additives are used.

For additional assembly related details please refer to technical note Assembly instructions of Dual Flat Lead Package (DFL).

APP 2702 Assembly_Instructions_for_DFL_Package

8 Frequently Asked Questions

- How can I be sure SPI communication is working?
 - Read register WHOAMI (10h), the response should be 51h.
- Why do I get wrong results when I read data?
 - SCA3300-D01 uses off-frame protocol (see 5.1.2 Protocol), make sure to utilize this correctly.
 - Confirm that the SPI frame is according to frame specified in (see 5.1.3 SPI Frame). Note that all 32 bits must be included in to the frame.
 - Confirm time between SPI requests (CSB high) is at least 10 μs.
 - Ensure SCA3300-D01 is correctly started (see 4.2 Start-up Sequence).
 - Read RS bits (see 5.1.5 Return Status), if error is shown read Status Summary (see 6.3 STATUS for further information).
 - Confirm correct sensitivity is used for current operation mode (see 4.3 Operation Modes)

9 Order Information

Order Code	Description	Measurement Range (g)	Packing	Qty
SCA3300-D01-004	3-axis industrial accelerometer with digital SPI interface	$\pm 1.5g, \pm 3g, \pm 6g$	Bulk	4pcs
SCA3300-D01-1	3-axis industrial accelerometer with digital SPI interface	$\pm 1.5g, \pm 3g, \pm 6g$	T&R	100pcs
SCA3300-D01-10	3-axis industrial accelerometer with digital SPI interface	$\pm 1.5g, \pm 3g, \pm 6g$	T&R	1000pcs