

PRODUCT NUMBER
90311-0XXLF

TOTAL NUMBER OF POS 04 UP TO 50

NOTES:

- 1 - MATERIAL : PA66 25% GLASSFILLED, UL94V-0 COLOR BLACK.
- 2 - SHEET 2 SHOWS THE SINGULAR LATCHING FEATURE FOR 2X2
- 3 - PRODUCT MEETS EUROPEAN UNION DIRECTIVES AND OTHERS REGULATIONS AS DESCRIBED IN GS-22-008.
- 4 - THIS PRODUCT IS NOT INTENDED TO BE EXPOSED TO MANUFACTURING SOLDER PROCESSES.
- 5 - CODING TRIANGLE INDICATES POS 1 WHEN MATED WITH MINITEK HEADER SERIES 98414 / 98417 / 98424 / 98464 / 10072354 / 10074920 AND 10075974.
- 6 - INDICATES POS 1, WHEN MATED WITH SERIES 90309 / 95609 / AND 95615.
- 7 - FOR USE WITH MINITEK CRIMP TO WIRE CONTACT 77138 (26-30AWG) AND 10044403 (22-24AWG).
- 8 - PRODUCT SPECIFICATION AS PER 110-036, CONTACT CRIMP RECOMMENDATIONS AS PER GS-20-058

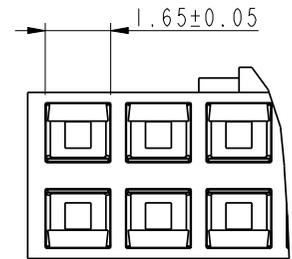
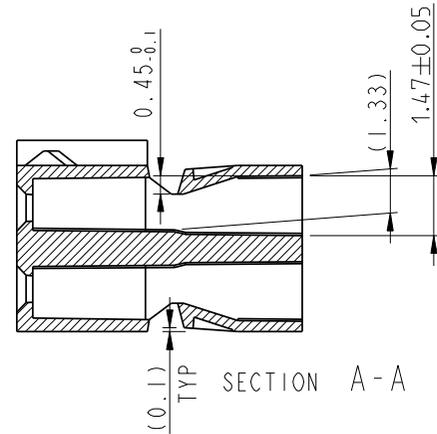
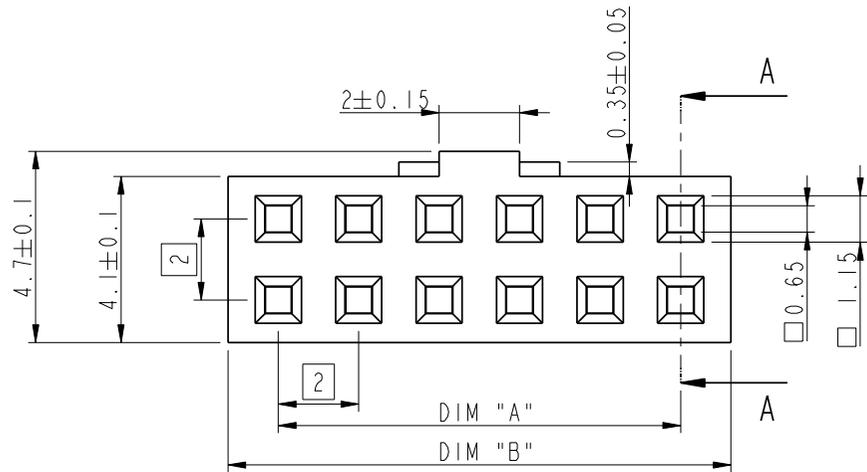
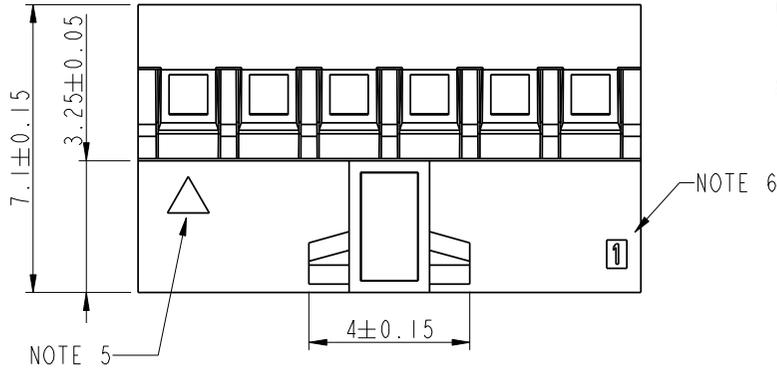

TOLERANCES UNLESS OTHERWISE SPECIFIED				
LINEAR	0.X	±0.3	-	-
	0.XX	±0.13	-	-
	0.XXX	±0.050	-	-
ANGULAR	0°	±2°	-	-

Material	SEE NOTE 1	Spec ref	
Mat code	N/A	tolerance	projection
Heat treat	N/A		
Plating/Finish	N/A		
Dr	D WHITING	1991-08-27	size A3
Eng	S. OLSON	1991-08-27	
Chr	J. COMPAGNON	11.12.01	Product family MINITEK
Appr	JCO	11.12.01	Model Name 90311
			Model Revision
			REL Level proj_release
FCI	Title	MINITEK CTW HSG.DBL ROW	
		POL & LATCHING, HIGH TEMPERATURE	
Pro/E file	catalog no	90311	Rev. W
		CUSTOMER	sheet 1 of 2

FCI CONFIDENTIAL



This document is the property of and embodies CONFIDENTIAL and PROPRIETARY information of FCI. No part of the information shown on this document may be used in any way or disclosed to others without the written consent of FCI. Copyright FCI.

PRODUCT NUMBER	SIZE	DIM A	DIM B
90311-004LF	2x2	2.0	4.4
90311-006LF	2x3	4.0	6.4
90311-008LF	2x4	6.0	8.4
90311-010LF	2x5	8.0	10.4
90311-012LF	2x6	10.0	12.4
90311-014LF	2x7	12.0	14.4
90311-016LF	2x8	14.0	16.4
90311-018LF	2x9	16.0	18.4
90311-020LF	2x10	18.0	20.4
90311-022LF	2x11	20.0	22.4
90311-024LF	2x12	22.0	24.4
90311-026LF	2x13	24.0	26.4
90311-028LF	2x14	26.0	28.4
90311-030LF	2x15	28.0	30.4
90311-032LF	2x16	30.0	32.4
90311-034LF	2x17	32.0	34.4
90311-036LF	2x18	34.0	36.4
90311-038LF	2x19	36.0	38.4
90311-040LF	2x20	38.0	40.4
90311-042LF	2x21	40.0	42.4
90311-044LF	2x22	42.0	44.4
90311-046LF	2x23	44.0	46.4
90311-048LF	2x24	46.0	48.4
90311-050LF	2x25	48.0	50.4

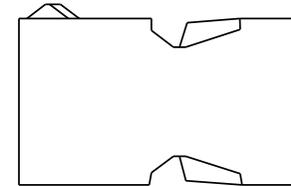
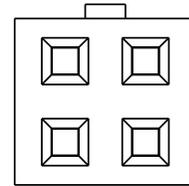
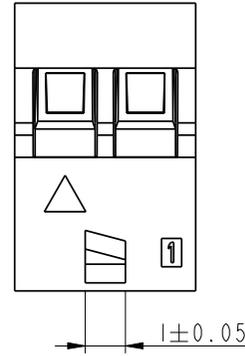

Material		Spec ref		
Mat code	Heattreat	✓	tolerance	projection
Plating/Finish	Dr		MM	←→
Dr	D WHITING	1991-08-27	size	A3
Eng	S. OLSON	1991-08-27	Product family	Scale 8:1
Chr	J.COMPAGNON	11.12.01	Model Name	90311
Appr	JCO	11.12.01	Model Revision	REL Level proi_release
FCI		title	90311	Rev. W
POL & LATCHING, HIGH TEMPERATURE		Pro/E file	catalog no	CUSTOMER
sheet 2 of 2		STATUS: Released		