

LOC		DIST		REVISIONS			
GP	00	P	LTR	DESCRIPTION	DATE	DMN	APVD
D				REVISED PER ECO-11-010351	10AUG2011	CJV	CWR

- 1 FLAME RETARDANT 94V-0 RATED THERMOPLASTIC; BLACK.
- 2 2.54µm [.000100] MIN MATTE TIN ON TERMINATION END, 0.76µm [.000030] MIN GOLD ON CONTACT AREA, ALL OVER 1.27µm [.000050] MIN NICKEL.
-OR-
GOLD FLASH OVER PALLADIUM-NICKEL 0.76µm [.000030] TOTAL ON CONTACT AREA, 2.54µm [.000100] MIN MATTE TIN ON TERMINATION END, ALL OVER 1.27µm [.000050] MIN NICKEL.
- 3 NO SLOT ON THIS END FOR 10 POSITION HOUSINGS.
- 4 NO SLOT FOR SNAP-IN POLARIZER ON THIS END FOR 10 AND 14 POSITION HOUSINGS.
- 5 FOR MILITARY POLARIZATION, ORDER SNAP-IN POLARIZER 499991-2 (BULK PACK 50)
- 6 POLARIZER POSITION NO 1 INDICATOR.
- 7 COORDINATE DIMENSION APPLIES FROM CENTER OF ACTUAL FEATURE.
- 8 FOR LATCHES ORDER 111451, 2 PER ASSEMBLY.
- 9 PHOSPHOR BRONZE PER QQ-B-750.
- 10 OBSOLETE.

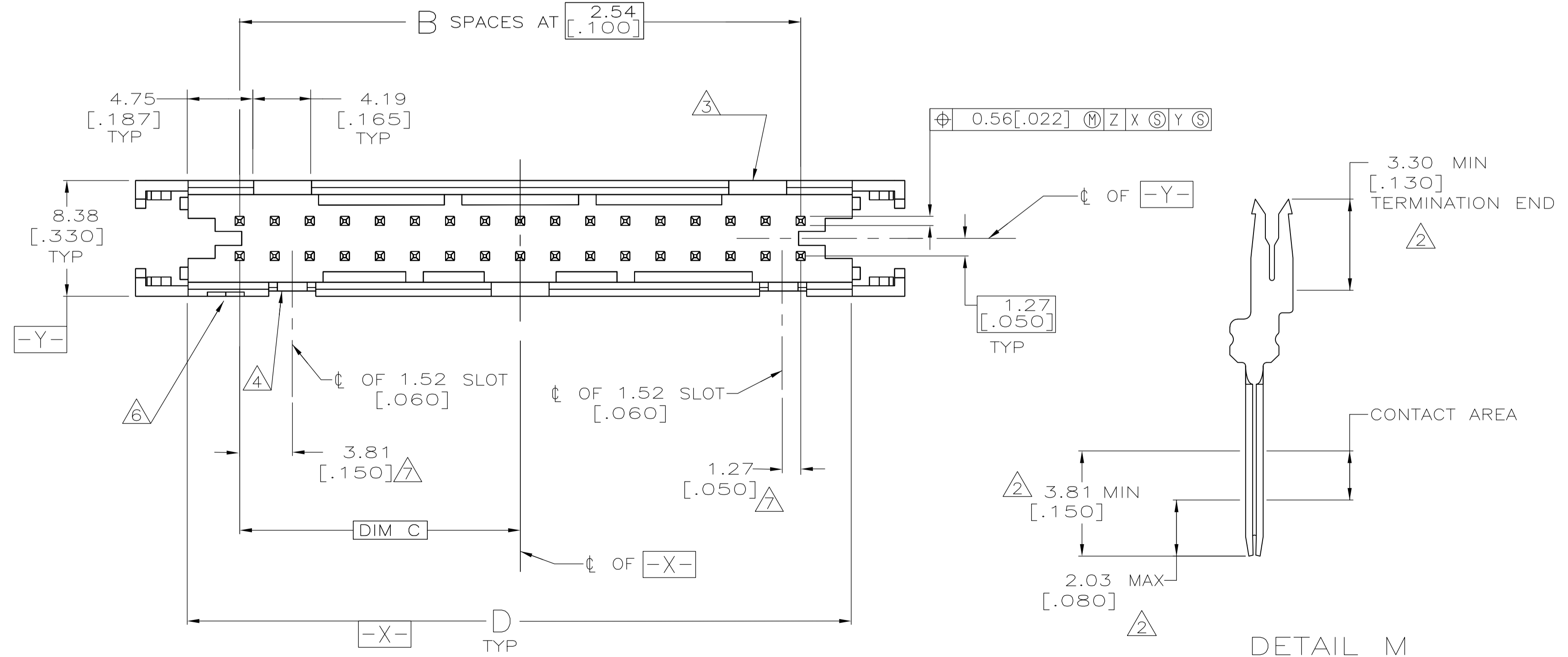
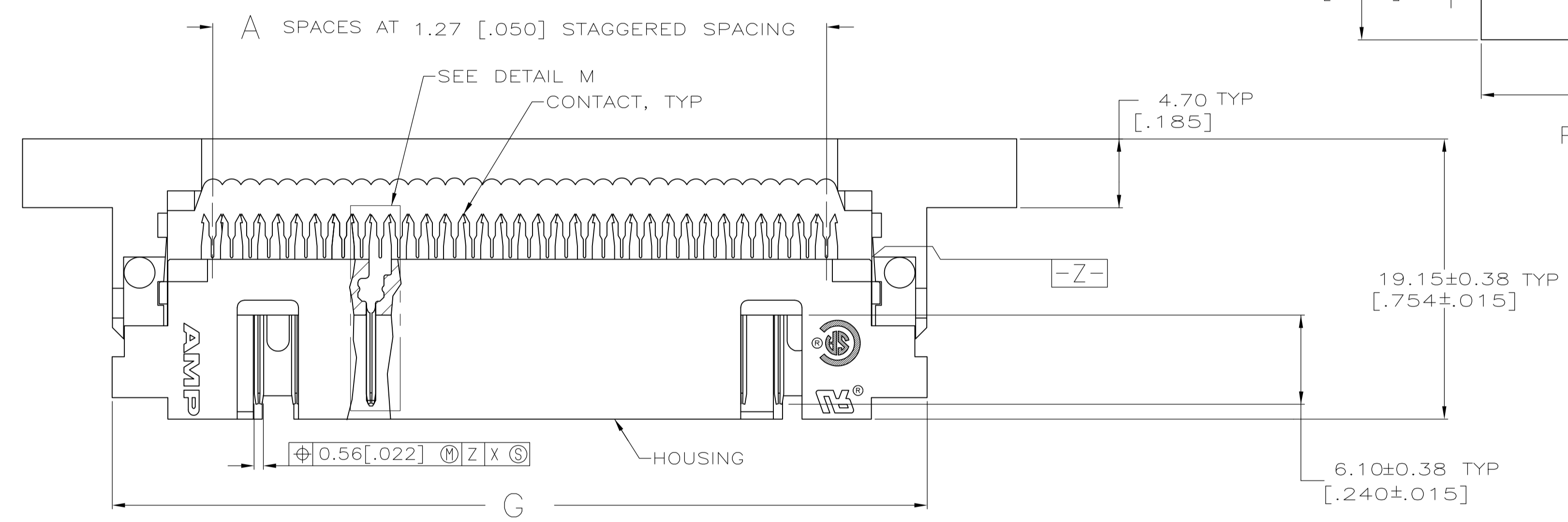
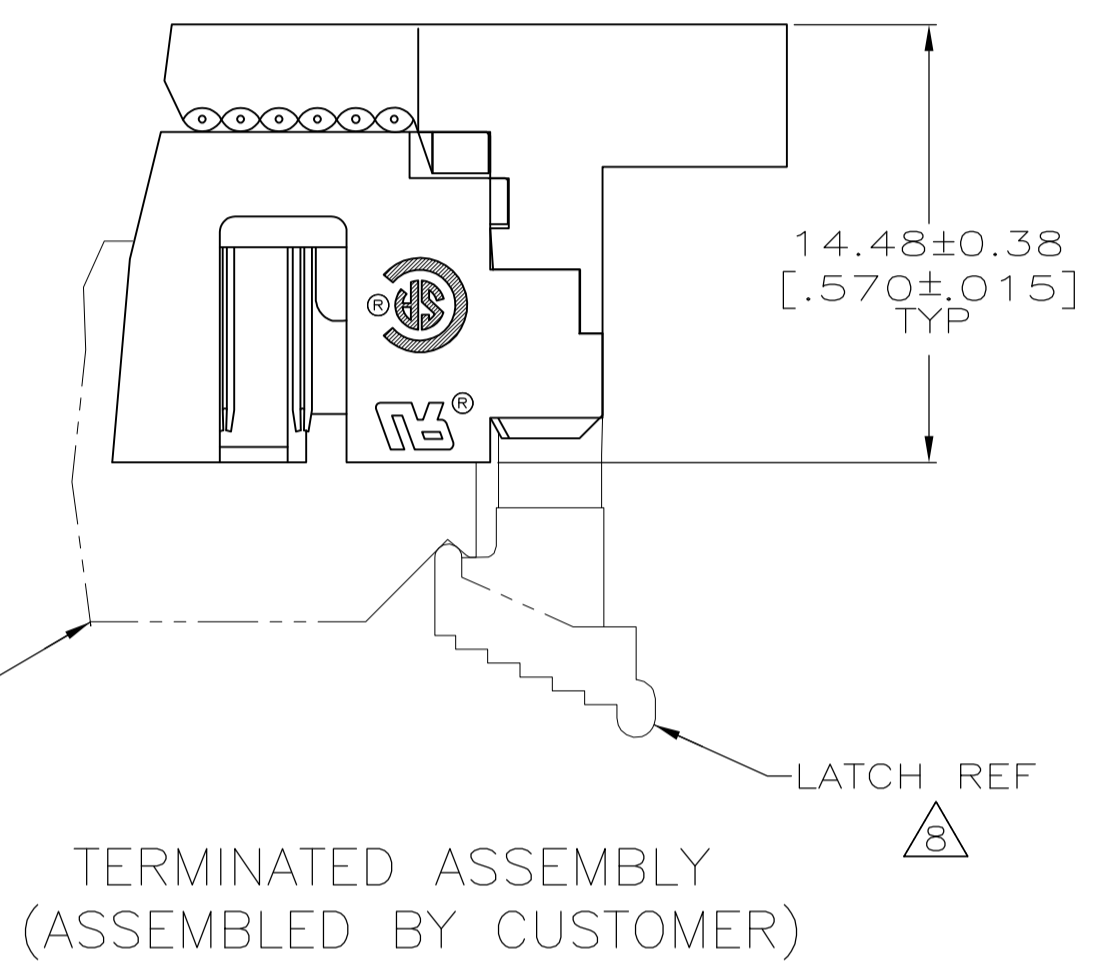
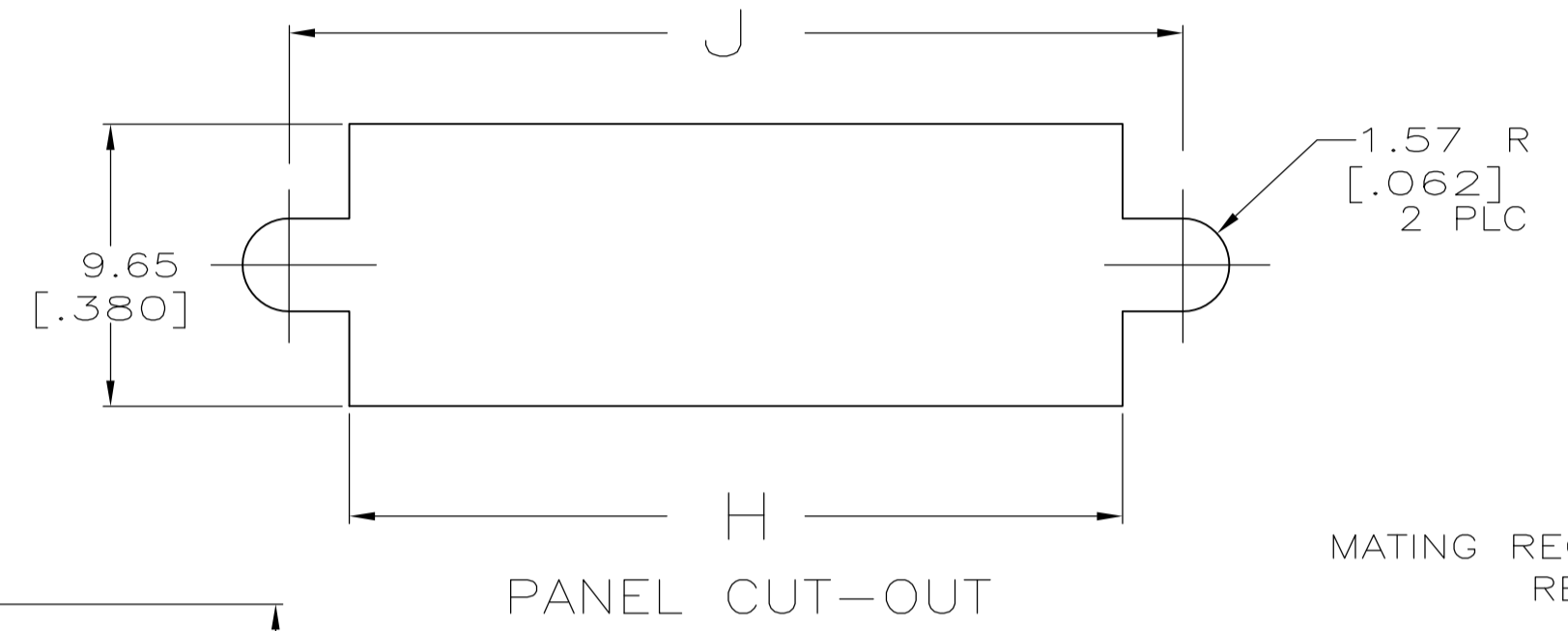
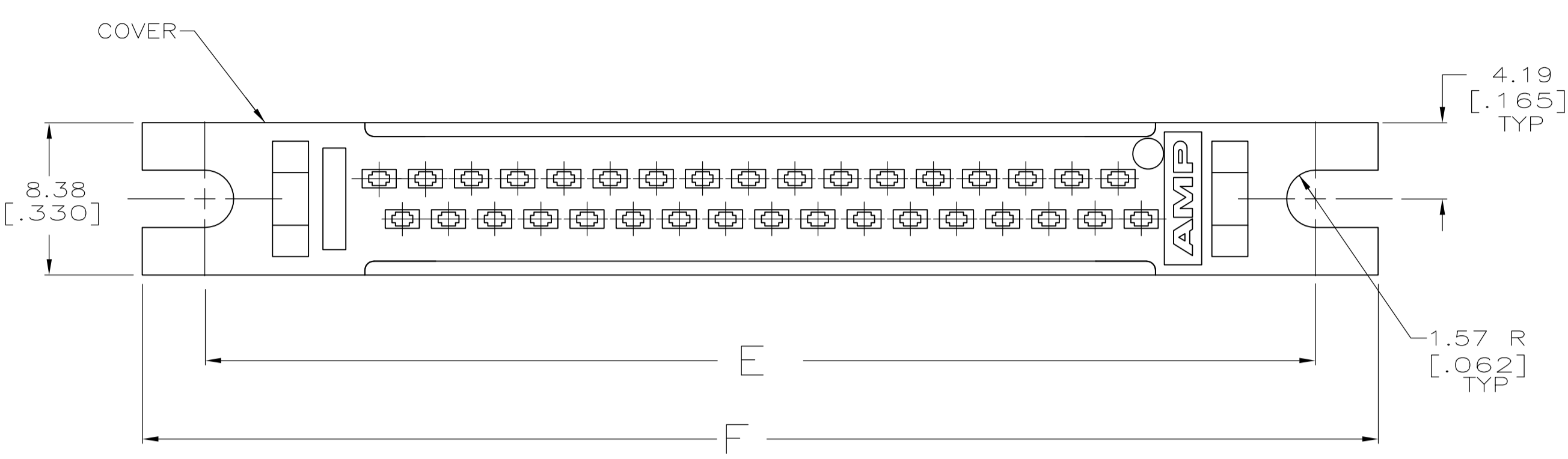

99.16	95.05	93.78	106.07	99.16	86.21	39.37	31	63	64	1-5111448-3
[3.904]	[3.742]	[3.692]	[4.176]	[3.904]	[3.394]	[1.550]				
94.08	89.97	88.70	100.99	94.08	81.13	36.83	29	59	60	1-5111448-2
[3.704]	[3.542]	[3.492]	[3.976]	[3.704]	[3.194]	[1.450]				
81.38	77.27	68.38	88.29	81.38	68.43	30.48	24	49	50	1-5111448-1
[3.204]	[3.042]	[2.992]	[3.476]	[3.204]	[2.694]	[1.200]				
73.76	69.65	68.38	80.67	73.76	60.81	26.67	21	43	44	1-5111448-0
[2.904]	[2.742]	[2.692]	[3.176]	[2.904]	[2.394]	[1.050]				
68.68	64.57	63.30	75.59	68.68	55.73	24.13	19	39	40	5111448-9
[2.704]	[2.542]	[2.492]	[2.976]	[2.704]	[2.194]	[.950]				
61.06	56.95	55.68	67.97	61.06	48.11	20.32	16	33	34	5111448-8
[2.404]	[2.242]	[2.192]	[2.676]	[2.404]	[1.894]	[.800]				
55.98	51.87	50.60	62.89	55.98	43.03	17.78	14	29	30	5111448-7
[2.204]	[2.042]	[1.992]	[2.476]	[2.204]	[1.694]	[.700]				
50.90	46.79	45.52	57.81	50.90	37.95	15.24	12	25	26	5111448-6
[2.004]	[1.842]	[1.792]	[2.276]	[2.004]	[1.494]	[.600]				
48.36	44.25	42.98	55.27	48.36	35.41	13.97	11	23	24	5111448-5
[1.904]	[1.742]	[1.692]	[2.176]	[1.904]	[1.394]	[.550]				
43.28	39.17	37.90	50.19	43.28	30.33	11.43	9	19	20	5111448-4
[1.704]	[1.542]	[1.492]	[1.976]	[1.704]	[1.194]	[.450]				
38.20	34.09	32.82	45.11	38.20	25.25	8.89	7	15	16	5111448-3
[1.504]	[1.342]	[1.292]	[1.776]	[1.504]	[.994]	[.350]				
35.66	31.55	30.28	42.57	35.66	22.71	7.62	6	13	14	5111448-2
[1.404]	[1.242]	[1.192]	[1.676]	[1.404]	[.894]	[.300]				
30.58	26.47	25.20	37.49	30.58	17.63	5.08	4	9	10	5111448-1
[1.204]	[1.042]	[.992]	[1.476]	[1.204]	[.694]	[.200]				
J	H	G	F	E	D	C	B	A	NO OF POSN	PART NUMBER

COVER NOT SHOWN IN THIS VIEW FOR CLARITY

DETAIL M SCALE 8:1 TYPICAL

THIS DRAWING IS A CONTROLLED DOCUMENT.

DIMENSIONS: mm [INCHES]	TOLERANCES UNLESS OTHERWISE SPECIFIED:	DIN B MCMASER 22JULY04	APPROVED: M. WALSLEY 22JULY04	NAME: UNIVERSAL I/O PIN CONNECTOR, WITH SLOTTED MOUNTING EARS, AMP-LATCH
0 PLC ± .01	1 PLC ± .015	2 PLC ± .02	3 PLC ± .03	4 PLC ± .05
ANGLES ± .5				
MATERIAL: 1	FINISH: 2	WEIGHT: -	SIZE: A1	SCALE: 4:1
CUSTOMER DRAWING		DRAWING NO: 00779	DRAWING NO: 5111448	SHEET 1 OF 1