

Sensitivity Wavelength Range: 600nm ~ 1750nm

The 1346 series from Marktech, a high sensitivity and high reliability product series, is ideally suited for Optical Communication devices. Custom packaging options for this die are also available.

FEATURES

- > High Speed Response (Max: 2Gbps)
- > TO-46 Metal Can Package
- > Active Area of 1.0mm / High Sensitivity
- > Spectral Range: 600nm - 1750nm

APPLICATIONS

- > High Speed Optical Communications
- > Industrial Controls
- > Optical Switches
- > LIDAR
- > Medical



Absolute Maximum Ratings (Ta=25°C)

ITEMS	SYMBOL	RATINGS	UNIT
Active Area	Φ	1.0	mm
Operating Temperature Range	Topr	-40 to +85	°C
Storage Temperature Range	Tstg	-40 to +125	°C

Electrical & Optical Characteristics (Ta = 25°C)

ITEMS	SYMBOL	CONDITIONS	MIN	TYP	MAX	UNIT
Breakdown Voltage	VR	IR= 10uA	3	--	--	V
Sensitivity Range	λ	VR=0V	600	--	1750	nm
Dark Current	ID	VR=1V	--	--	2.0	uA
Junction Capacitance	C	VR=0V	--	60	--	pF
Light Current @1300nm *1	IL	λ=1300nm; *2	--	180	--	uA
Responsivity	R	λ=1550nm	--	0.70	--	A/W
Quantum Efficiency	QE	λ=1660nm	--	55	--	%
Shunt Resistance	RSH	VR= 10mV	--	2	--	MΩ
Switching Times	Tr, Tf	VR=2V	--	0.63	--	ns

*1: As mounted on TO-46 header without resin coating. *2: VR=2V

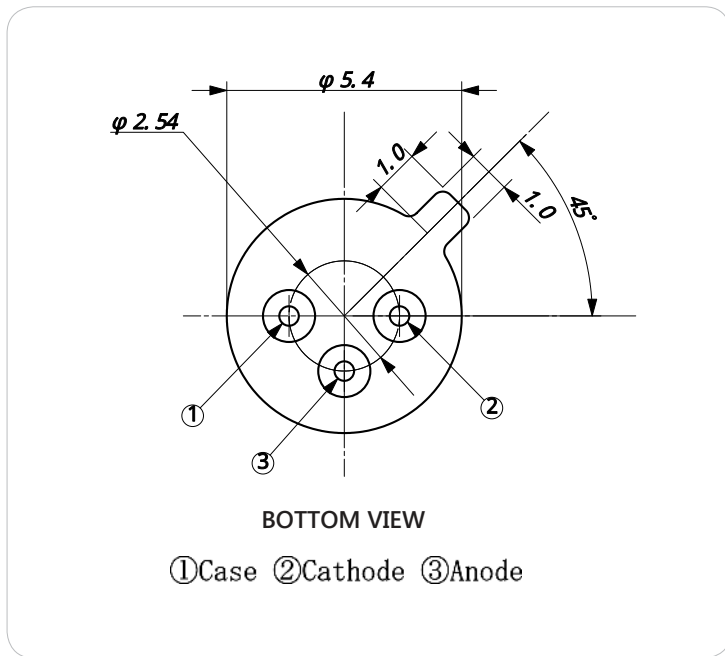
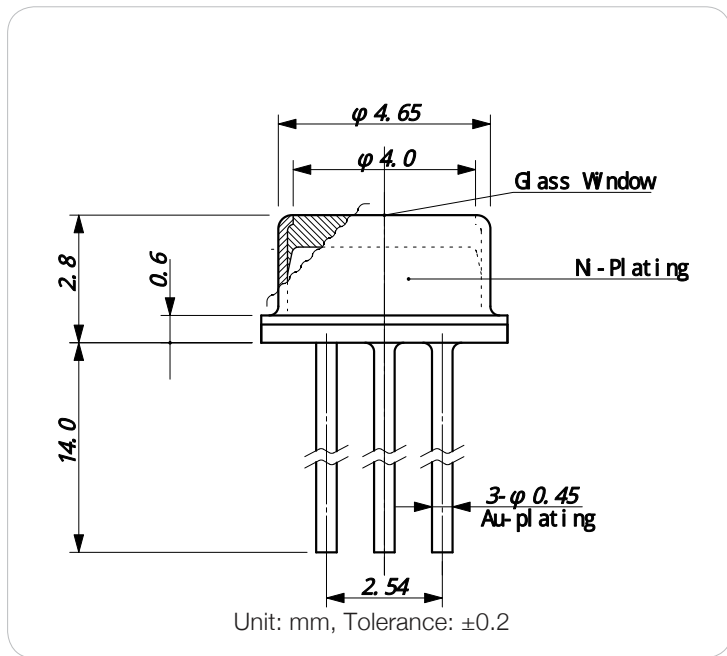

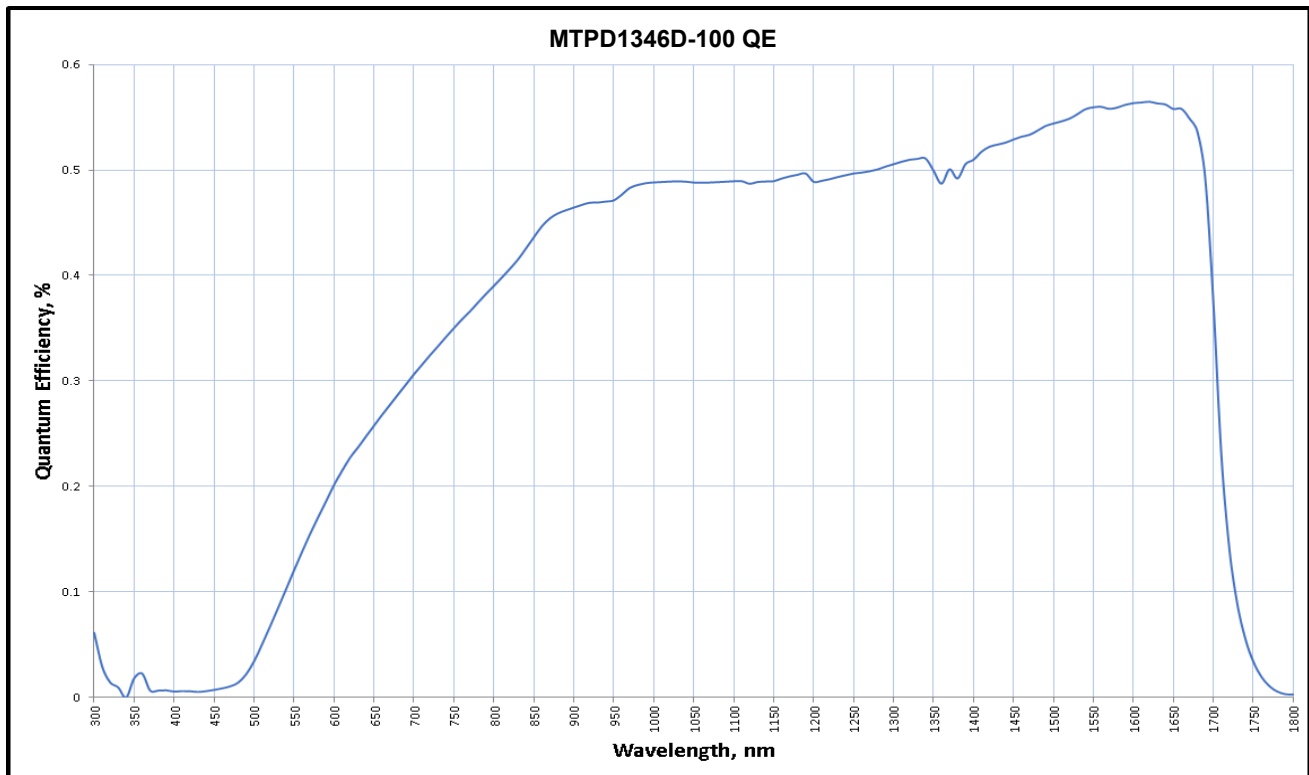
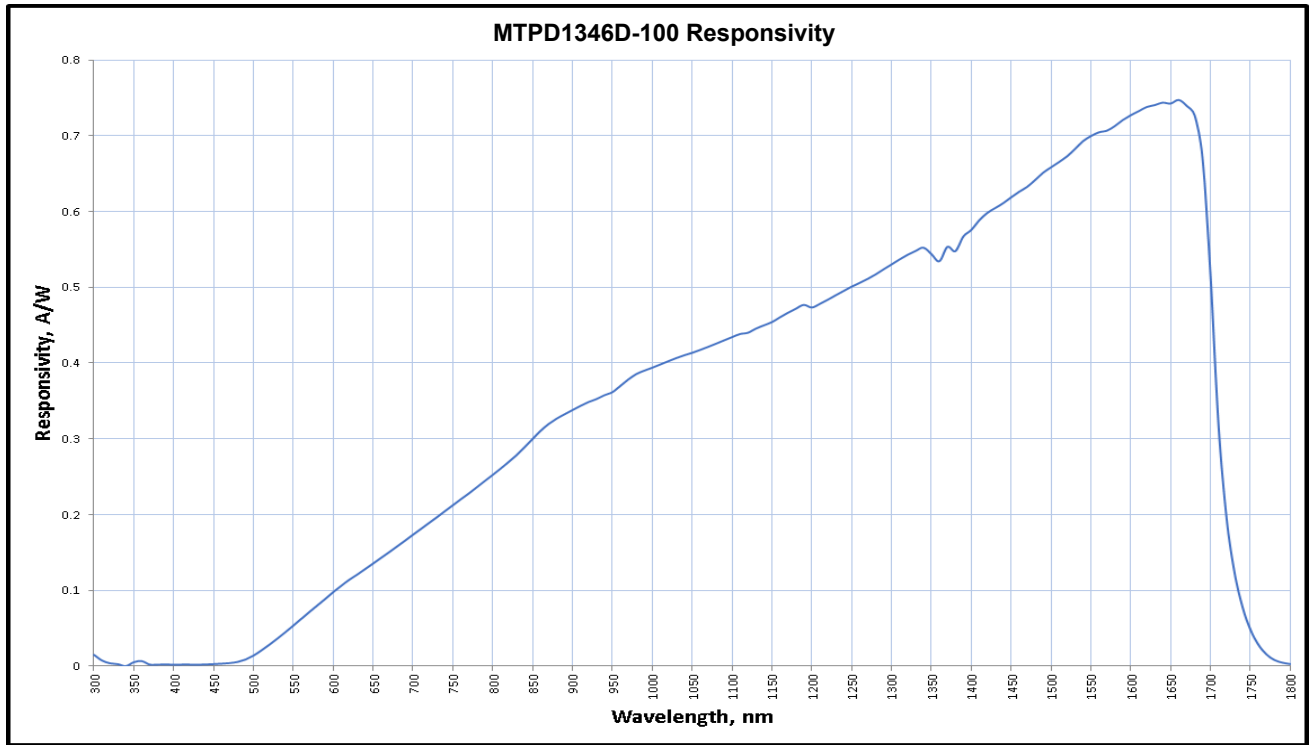

The information contained herein is subject to change without notice.

2021-08-17