

1

2

3

4

5

6

7

A

B

C

D

E

F

A

B

C

D

E

F

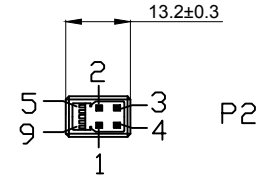
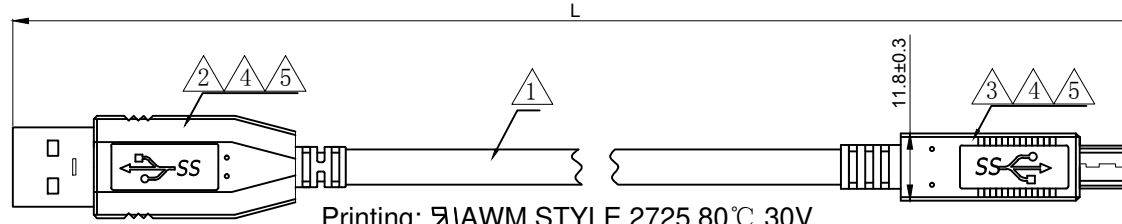
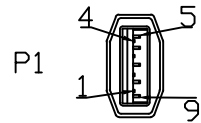

Printing: ㊦AWM STYLE 2725 80°C 30V
 VW-1 SUPER HIGH SPEED USB Revision 3.0

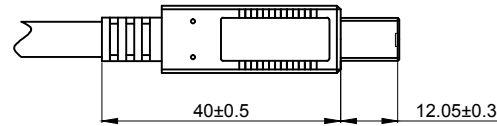
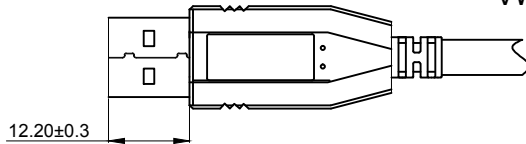

① Pin Assignment

P1		P2
1	Red	1
2	White	2
3	Green	3
4	Black	4
5	Blue	5
6	Yellow	6
7	Drain	7
8	Orange	8
9	Purple	9
Shell	Braid	Shell

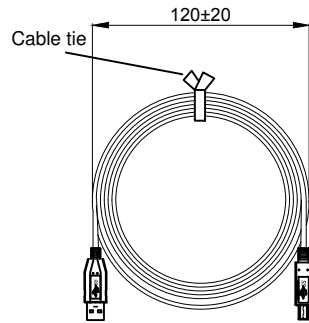

NOTES:

1. Cable Must Be Open, Short, Miswire 100% Test
2. Voltage: 300V DC
3. Contact Resistance: 5ohms max.
4. Insulation Resistance: 10M ohms min.
5. 1Pcs/PE Bag

②

WSW P/N	Length(mm)	Qty/Per Carton
A-USB30AM-30BM-050	500±20	200
A-USB30AM-30BM-100	1000±30	150
A-USB30AM-30BM-200	2000±50	100
A-USB30AM-30BM-300	3000±50	70
A-USB30AM-30BM-500	5000±50	50

②

NO.	TITLE	DESCRIPTION
△	Inner Mold	LDPE WHITE
△	Over Mold	PVC 45P Black
△	CONN	USB3.0 B/M, Blue PBT, PIN G/F, Shell Ni-Plated
△	CONN	USB3.0 A/M, Blue PBT, PIN G/F, Shell Ni-Plated
△	CABLE	UL2725(Rev 3.0), OD:5.5mm BLACK, (1P#30+D+AL+Mylar)*2C+1P#30+2C#24+AL+B

RoHS compliant
 Unit: mm

Scale	FREE					Date	Name	Customer-No.
TOLERANCE						Drawn	07.01.2019	Xavier
						Approved	10.12.2019	Winnie
		②	Packing quantities & PVC hardness	10.12.2019	Winnie			
DIM	TOL	①	Add wire color	07.15.2019	Xavier			
		①	Drawn	07.01.2019	Xavier			
Angle	TOL	Id.	Modification	Date	Name	Replace	Sheet	1/1

ASSMANN WSW-No.
A-USB30AM-30BM-xxx

Drawing-No.
ASS 8453 CA rev02

1

2

3

4

5

6

7