

OV7690 VGA product brief



1/13 inch VGA CameraChip™ sensor with OmniPixel3™ technology

The OV7690 is the world's smallest single-chip, high-performance VGA CameraChip image sensor, with an optical format of only 1/13-inch. Using a new generation of the OmniPixel3-HS™ (High Sensitivity) architecture, the OV7690 offers improved signal-to-noise ratio and unparalleled light sensitivity.

The OV7690's unique, non-linear micro lens shift technology, coupled with the newly developed CSP3 packaging technology, frees product designers to develop unique, slim devices incorporating VGA sensors.

This technology allows for ultra-thin camera modules with a single plastic lens design of just 4.5 x 4.5 x 3.17 mm, a critical characteristic for slim camera phones and notebook applications where camera modules can be no thicker than the LCD housing.

Integrating image processing functions on-chip, the low-voltage OV7690 image sensor provides the full functionality of a VGA camera and image processor in a small footprint package. This includes full-frame, sub-sampled or windowed 8-bit images in a wide range of formats, controlled through a serial camera control bus (SCCB) interface.

The OV7690 can operate at 30 frames per second (fps) in VGA with full user control over image quality, formatting and output data transfer. As part of OmniVision's next generation of image sensors, the OV7690 delivers low-noise, low-cost, low-power consumption, high integration, wide dynamic range and excellent low-light performance.

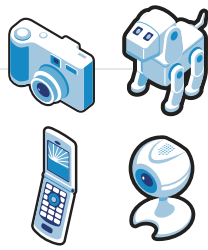

applications

- cellular phones
- toys
- PC multimedia
- digital still cameras

OV7690

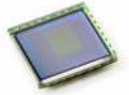

ordering information

- OV07690-AL9A
(color, lead-free, CSP3-20)

product features

- ultra low power and low cost
- automatic image control functions:
 - automatic exposure control (AEC)
 - automatic white balance (AWB)
 - automatic black level calibration (ABLC)
- programmable controls for frame rate, AEC/AGC, mirror and flip, scaling and windowing
- image quality controls:
 - color saturation
 - hue
 - gamma
 - sharpness (edge enhancement)
 - lens correction
 - defective pixel canceling
 - noise canceling
- support for video or snapshot operations
- support for horizontal and vertical sub-sampling
- support for image sizes:
 - VGA
 - scaling CIF
 - sub sampling QVGA
 - scaling QCIF
- standard serial SCCB interface
- digital video port (DVP) parallel output interface
- on-chip phase lock loop (PLL)
- programmable I/O drive capability
- support for black sun cancellation
- built-in 1.5V regulator for sensor core power
- rolling shutter

product specifications

- active array size: 640 x 480
- power supply:
 - analog: 2.6 - 3.0V
 - I/O: 1.7 - 3.0V
- active power requirement: 100 mW
- temperature range:
 - operating: -30°C to 70°C
 - stable image: 0°C to 50°C
- output formats (8-bit):
 - YUV 422/YCbCr422
 - RGB565
 - CCIR656
 - raw RGB data
- lens size: 1/13"
- input clock frequency: 6 - 27 MHz
- maximum image transfer rate:
 - VGA (640 x 480): 30fps for VGA
 - QVGA (320 x 240): 60fps for QVGA
- scan mode: progressive
- maximum exposure interval: 511 x t_{ROW}
- gamma correction: programmable

functional block diagram

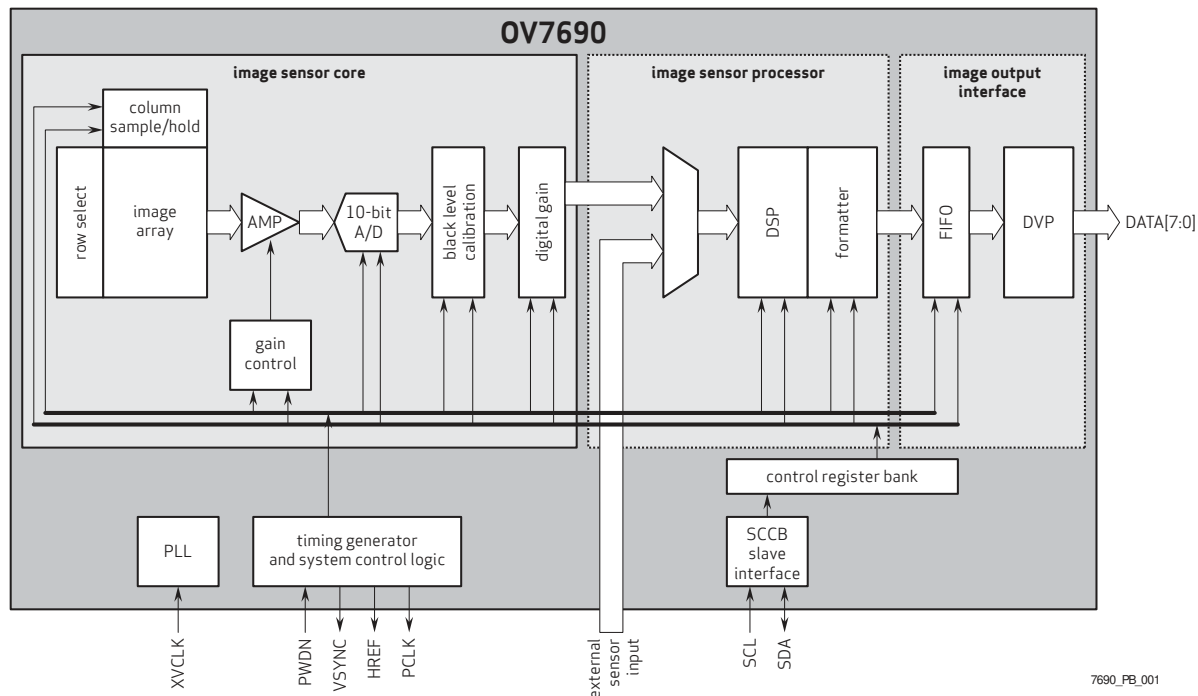

1341 Orleans Drive
Sunnyvale, CA 94089

tel: +1 408 542 3000
fax: +1 408 542 3001
www.ovt.com

OmniVision reserves the right to make changes to their products or to discontinue any product or service without further notice. OmniVision, the OmniVision logo and OmniPixel are registered trademarks of OmniVision Technologies, Inc. CameraChip and OmniPixel3 are trademarks of OmniVision Technologies, Inc. All other trademarks are the property of their respective owners.

