



± 4g / 8g / 16g Tri-axis Digital Accelerometer Specifications

PART NUMBER:

KXCJ9-1018
Rev. 2
Sep-2014

Product Description

The KXCJ9-1018 is a tri-axis +/-4g, +/-8g or +/-16g silicon micromachined accelerometer. The sense element is fabricated using Kionix's proprietary plasma micromachining process technology. Acceleration sensing is based on the principle of a differential capacitance arising from acceleration-induced motion of the sense element, which further utilizes common mode cancellation to decrease errors from process variation, temperature, and environmental stress. The sense element is hermetically sealed at the wafer level by bonding a second silicon lid wafer to the device using a glass frit. A separate ASIC device packaged with the sense element provides signal conditioning and digital communications. The accelerometer is delivered in a 3 x 3 x 0.9 mm LGA plastic package operating from a 1.8 – 3.6V DC supply. Voltage regulators are used to maintain constant internal operating voltages over the range of input supply voltages. This results in stable operating characteristics over the range of input supply voltages and virtually undetectable ratiometric error. The I²C digital protocol is used to communicate with the chip to configure the part and monitor outputs.

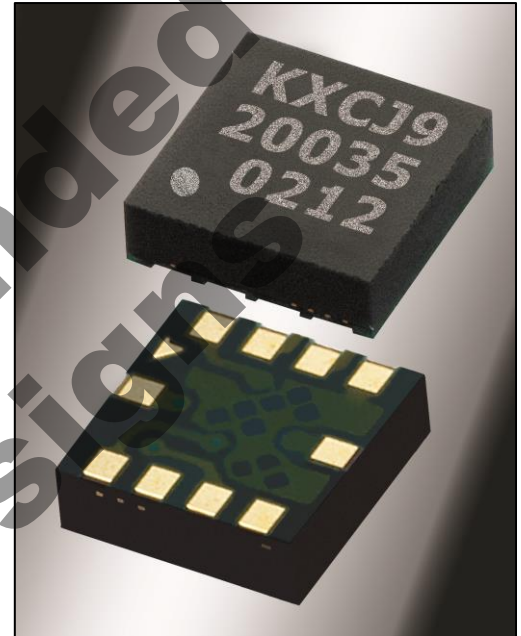



± 4g / 8g / 16g Tri-axis Digital Accelerometer Specifications

PART NUMBER:

KXCJ9-1018

Rev. 2

Sep-2014

Functional Diagram

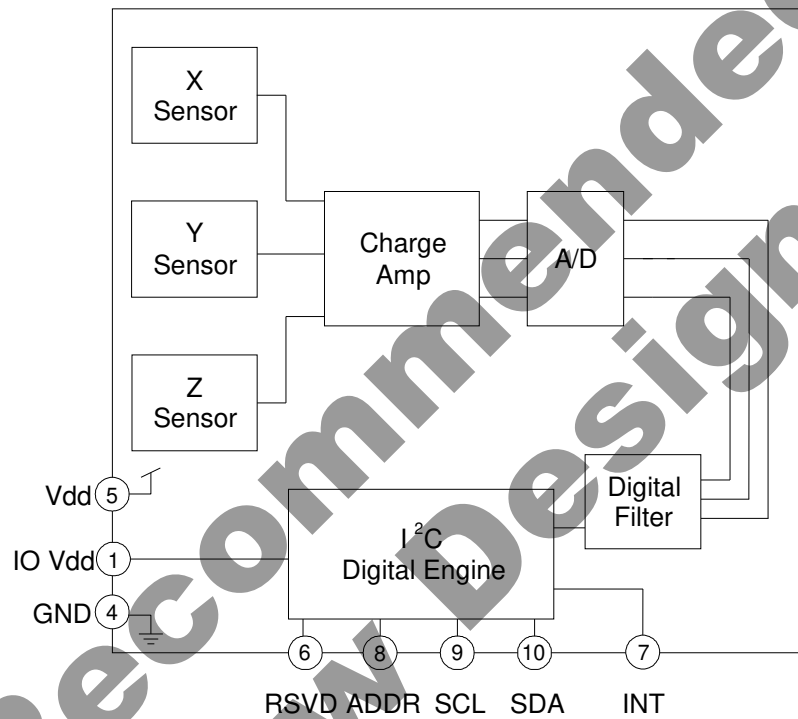



± 4g / 8g / 16g Tri-axis Digital Accelerometer Specifications

PART NUMBER:

**KXCJ9-1018
Rev. 2
Sep-2014**

Product Specifications

Table 1. Mechanical

(specifications are for operation at 2.6V and T = 25C unless stated otherwise)

Parameters		Units	Min	Typical	Max
Operating Temperature Range		°C	-40	-	85
Zero-g Offset		mg	-	±25	±125
Zero-g Offset Variation from RT over Temp.		mg/°C		0.2	
Sensitivity (14-bit) ^{1,2}	GSEL1=1, GSEL0=1 (± 16g)	counts/g	461	512	563
	GSEL1=0, GSEL0=0 (± 4g)		461	512	563
Sensitivity (12-bit) ¹	GSEL1=0, GSEL0=1 (± 8g)	counts/g	230	256	282
	GSEL1=1, GSEL0=0 (± 16g)		115	128	141
Sensitivity (8-bit) ¹	GSEL1=0, GSEL0=0 (± 4g)		27	32	36
	GSEL1=0, GSEL0=1 (± 8g)	counts/g	14	16	18
	GSEL1=1, GSEL0=0 (± 16g)		7	8	9
Sensitivity Variation from RT over Temp.		%/°C		0.03	
Self Test Output change on Activation		g		1 (x) 0.8 (y) 0.6 (z)	
Mechanical Resonance (-3dB) ³		Hz		3500 (xy) 1800 (z)	
Non-Linearity		% of FS		0.6	
Cross Axis Sensitivity		%		2	

Notes:

1. Resolution and acceleration ranges are user selectable via I²C.
2. 14-bit Resolution is only available for registers 0x06h – 0x0Bh in the 16g Full Power mode
3. Resonance as defined by the damped mechanical sensor.



± 4g / 8g / 16g Tri-axis Digital Accelerometer Specifications

PART NUMBER:

**KXCJ9-1018
Rev. 2
Sep-2014**

Table 2. Electrical

(specifications are for operation at 2.6V and T = 25C unless stated otherwise)

Parameters		Units	Min	Typical	Max
Supply Voltage (V _{dd})	Operating	V	1.71	2.6	3.6
I/O Pads Supply Voltage (V _{IO})		V	1.7		V _{dd}
Current Consumption	Full Power Mode (RES = 1)	μA		135	
	Low Power Mode ¹ (RES = 0)			10	
	Disabled			0.9	
Output Low Voltage (V _{io} < 2V) ²		V	-	-	0.2 * V _{io}
Output Low Voltage (V _{io} > 2V) ²		V	-	-	0.4
Output High Voltage		V	0.8 * V _{io}	-	-
Input Low Voltage		V	-	-	0.2 * V _{io}
Input High Voltage		V	0.8 * V _{io}	-	-
Input Pull-down Current		μA		0	
Start Up Time ³		ms	2.0		650
Power Up Time ⁴		ms		10	
I ² C Communication Rate		MHz			3.4
Output Data Rate (ODR) ⁵		Hz	0.781	50	1600
Bandwidth (-3dB) ⁶	RES = 0	Hz		800	
	RES = 1	Hz		ODR/2	

Notes:

1. Current varies with Output Data Rate (ODR) (see table below), DRDY and WUF settings.
2. For I²C communication, this assumes a minimum 1.5kΩ pull-up resistor on SCL and SDA pins.
3. Start up time is from PC1 set to valid outputs. Time varies with Output Data Rate (ODR); see chart below.
4. Power up time is from Vdd and IO_Vdd valid to device boot completion.
5. User selectable through I²C.
6. User selectable and dependent on ODR and RES.



± 4g / 8g / 16g Tri-axis Digital Accelerometer Specifications

PART NUMBER:

KXCJ9-1018
Rev. 2
Sep-2014

Table 3 Current Profile

KXCJ9 Representative Current Profile		
ODR (Hz)	RES	Current (µA)
0	Disabled	0.9
0.781	0	1.7
1.563	0	2
3.125	0	2.2
6.25	0	3.3
12.5	0	5
25	0	9
50	0	16
100	0	29
200	0	57
400	0	120
800	0	120
1600	0	120
All Rates	1	120

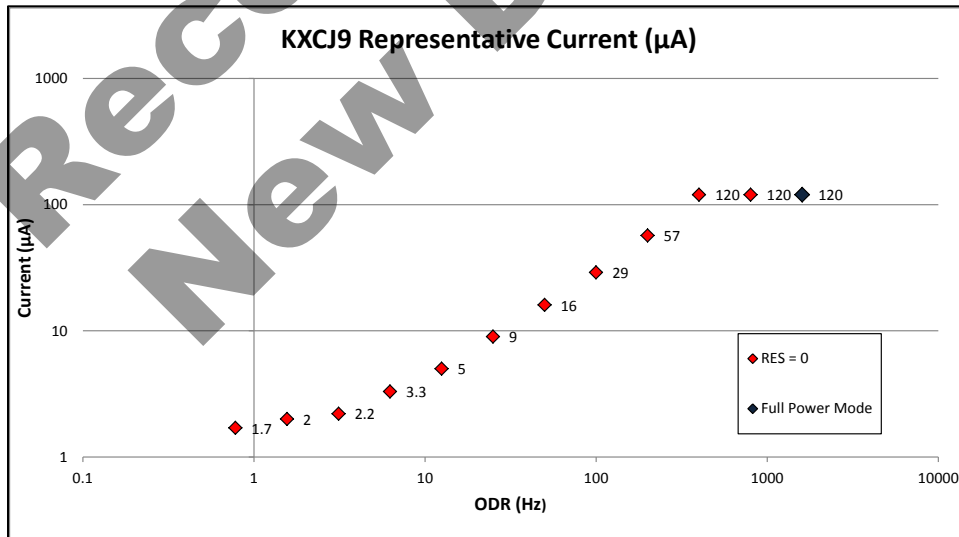



± 4g / 8g / 16g Tri-axis Digital Accelerometer Specifications

PART NUMBER:

KXCJ9-1018
Rev. 2
Sep-2014

Table 4 Start Up Time Profile

KXCJ9 Representative Start Up Time	
ODR (Hz)	Start Up Time (ms)
12.5	80
25	41
50	21
100	11
200	6.4
400	3.9
800	2.7
1600	2.1

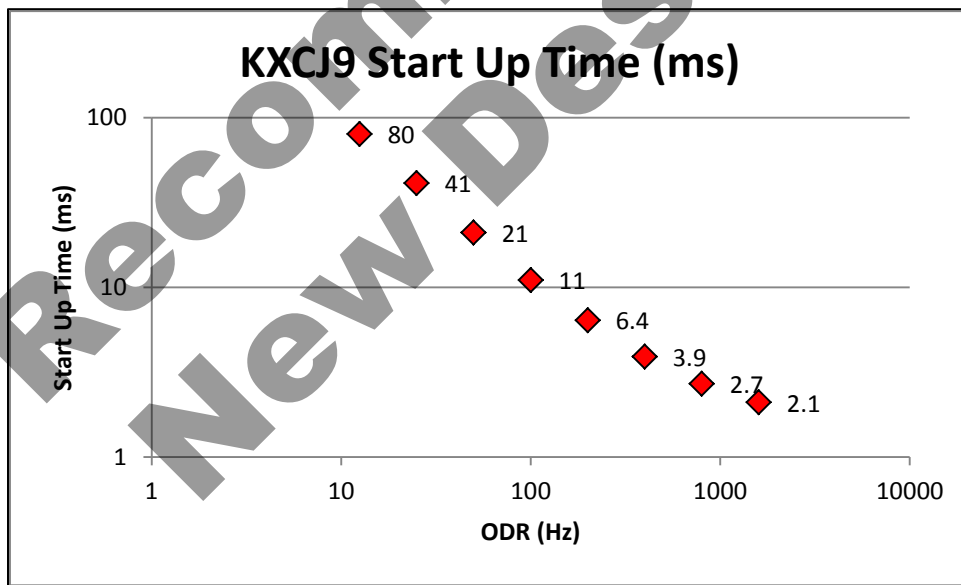

	± 4g / 8g / 16g Tri-axis Digital Accelerometer Specifications	PART NUMBER: KXCJ9-1018 Rev. 2 Sep-2014
---	--	--

Table 5. Environmental

Parameters		Units	Min	Typical	Max
Supply Voltage (V _{dd})	Absolute Limits	V	-0.5	-	3.63
Operating Temperature Range		°C	-40	-	85
Storage Temperature Range		°C	-55	-	150
Mech. Shock (powered and unpowered)		g	-	-	5000 for 0.5ms 10000 for 0.2ms
ESD	HBM	V	-	-	2000



Caution: ESD Sensitive and Mechanical Shock Sensitive Component, improper handling can cause permanent damage to the device.



This product conforms to Directive 2002/95/EC of the European Parliament and of the Council of the European Union (RoHS). Specifically, this product does not contain lead, mercury, cadmium, hexavalent chromium, polybrominated biphenyls (PBB), or polybrominated diphenyl ethers (PBDE) above the maximum concentration values (MCV) by weight in any of its homogenous materials. Homogenous materials are "of uniform composition throughout."



This product is halogen-free per IEC 61249-2-21. Specifically, the materials used in this product contain a maximum total halogen content of 1500 ppm with less than 900-ppm bromine and less than 900-ppm chlorine.

Soldering

Soldering recommendations are available upon request or from www.kionix.com.

Floor Life

Factory floor life exposure of the KXCJ9 reels removed from the moisture barrier bag should not exceed a maximum of 168 hours at 30C/60%RH. If this floor life is exceeded, the parts should be dried per the IPC/JEDEC J-STD-033A standard.



± 4g / 8g / 16g Tri-axis Digital Accelerometer Specifications

PART NUMBER:

KXCJ9-1018
Rev. 2
Sep-2014

Application Schematic

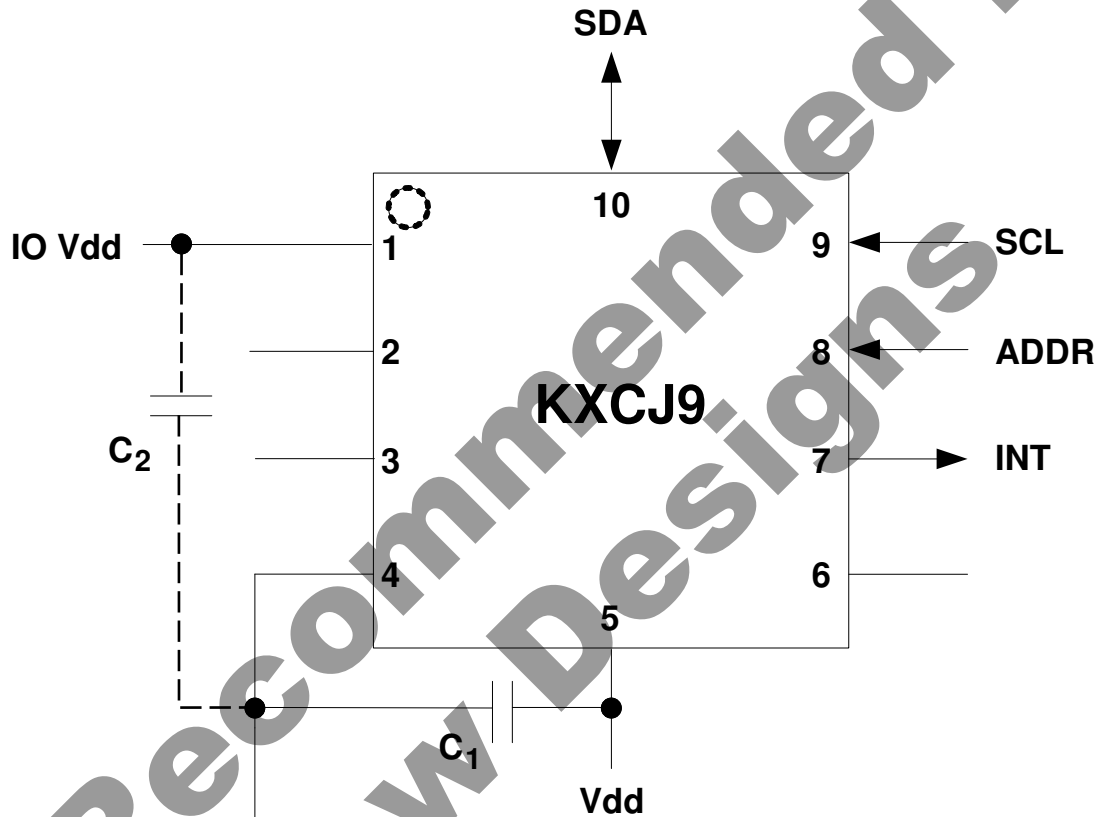

Table 6. KXCJ9 Pin Descriptions

Pin	Name	Description
1	IO Vdd	The power supply input for the digital communication bus. Optionally decouple this pin to ground with a 0.1uF ceramic capacitor.
2	DNC	Reserved – Do Not Connect
3	DNC	Reserved – Do Not Connect
4	GND	Ground
5	Vdd	The power supply input. Decouple this pin to ground with a 0.1uF ceramic capacitor.
6	RSVD	Reserved – Connect to Vdd, IO_Vdd, or GND
7	INT	Physical Interrupt
8	ADDR	I ² C programmable address bit – Connect to IO_Vdd or GND
9	SCL	I ² C Serial Clock
10	SDA	I ² C Serial Data



± 4g / 8g / 16g Tri-axis Digital Accelerometer Specifications

PART NUMBER:

KXCJ9-1018
Rev. 2
Sep-2014

Test Specifications



Special Characteristics:

These characteristics have been identified as being critical to the customer. Every part is tested to verify its conformance to specification prior to shipment.

Table 7. Test Specifications

Parameter	Specification	Test Conditions
Zero-g Offset @ RT	0 +/- 64 counts	25C, Vdd = 2.6 V
Sensitivity @ RT	512 +/- 51.2 counts/g	25C, Vdd = 2.6 V

Not Recommended for New Designs



± 4g / 8g / 16g Tri-axis Digital Accelerometer Specifications

PART NUMBER:

KXCJ9-1018
Rev. 2
Sep-2014

Package Dimensions and Orientation

3 x 3 x 0.9 mm LGA

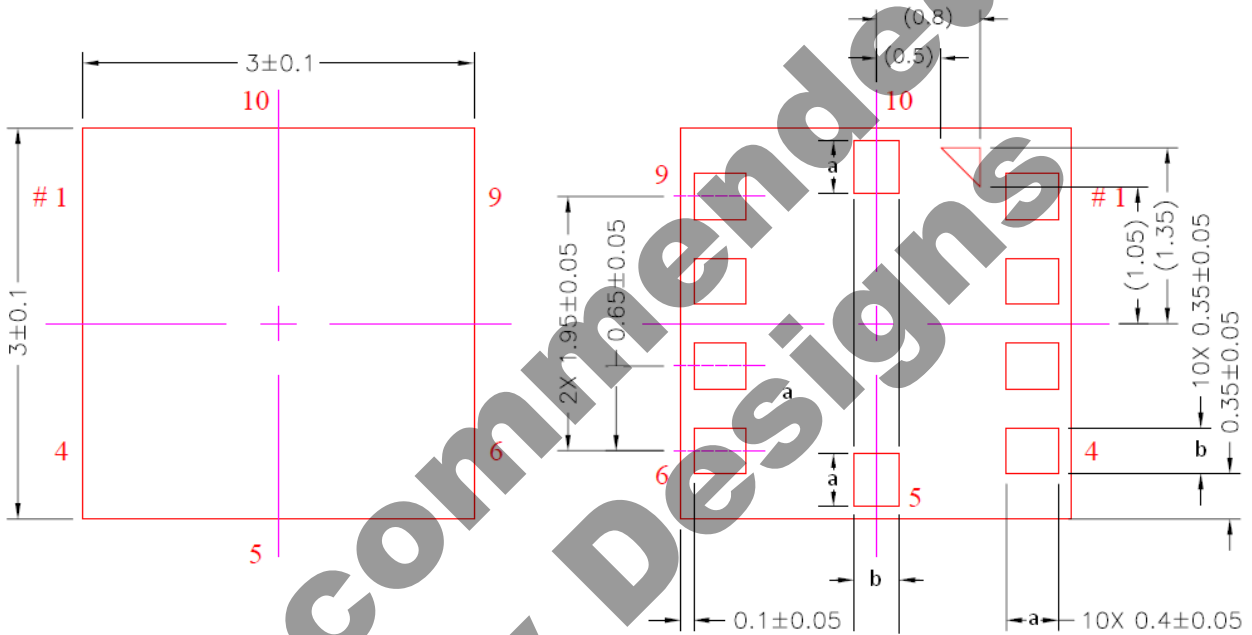

TOP VIEW

BOTTOM VIEW

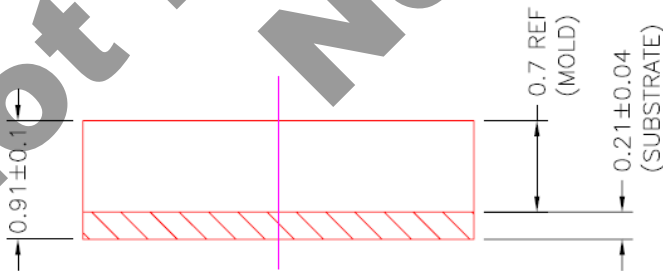

SIDE VIEW

All dimensions and tolerances conform to ASME Y14.5M-1994



± 4g / 8g / 16g Tri-axis Digital Accelerometer Specifications

PART NUMBER:

KXCJ9-1018
Rev. 2
Sep-2014

Orientation

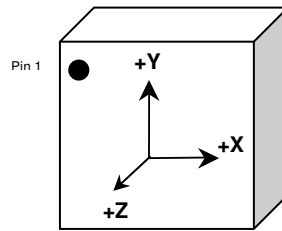

When device is accelerated in +X, +Y or +Z direction, the corresponding output will increase.

Static X/Y/Z Output Response versus Orientation to Earth's surface (1g):

GSEL1=0, GSEL0=0 (± 4g)

Position	1		2		3		4		5		6	
Diagram									Top Bottom		Bottom Top	
Resolution (bits)	12	8	12	8	12	8	12	8	12	8	12	8
X (counts)	0	0	512	32	0	0	-512	-32	0	0	0	0
Y (counts)	512	32	0	0	-512	-32	0	0	0	0	0	0
Z (counts)	0	0	0	0	0	0	0	0	512	32	-512	-32
X-Polarity	0		+		0		-		0		0	
Y-Polarity	+		0		-		0		0		0	
Z-Polarity	0		0		0		0		+		-	

↓ (1g)

Earth's Surface



± 4g / 8g / 16g Tri-axis Digital Accelerometer Specifications

PART NUMBER:

KXCJ9-1018
Rev. 2
Sep-2014

Static X/Y/Z Output Response versus Orientation to Earth's surface (1g): GSEL1=0, GSEL0=1 (± 8g)

Position	1		2		3		4		5		6	
Diagram									Top 		Bottom 	
Resolution (bits)	12	8	12	8	12	8	12	8	12	8	12	8
X (counts)	0	0	256	16	0	0	-256	-16	0	0	0	0
Y (counts)	256	16	0	0	-256	-16	0	0	0	0	0	0
Z (counts)	0	0	0	0	0	0	0	0	256	16	-256	-16
X-Polarity	0		+		0		-		0		0	
Y-Polarity	+		0		-		0		0		0	
Z-Polarity	0		0		0		0		+		-	

↓ (1g)
Earth's Surface

Static X/Y/Z Output Response versus Orientation to Earth's surface (1g): GSEL1=1, GSEL0=0 (± 16g)

Position	1		2		3		4		5		6	
Diagram									Top 		Bottom 	
Resolution (bits)	12	8	12	8	12	8	12	8	12	8	12	8
X (counts)	0	0	128	8	0	0	-128	-8	0	0	0	0
Y (counts)	128	8	0	0	-128	-8	0	0	0	0	0	0
Z (counts)	0	0	0	0	0	0	0	0	128	8	-128	-8
X-Polarity	0		+		0		-		0		0	
Y-Polarity	+		0		-		0		0		0	
Z-Polarity	0		0		0		0		+		-	

↓ (1g)
Earth's Surface



± 4g / 8g / 16g Tri-axis Digital Accelerometer Specifications

PART NUMBER:

KXCJ9-1018
Rev. 2
Sep-2014

KXCJ9 Digital Interface

The Kionix KXCJ9 digital accelerometer has the ability to communicate on the I²C digital serial interface bus. This allows for easy system integration by eliminating analog-to-digital converter requirements and by providing direct communication with system micro-controllers.

The serial interface terms and descriptions as indicated in Table 8 below will be observed throughout this document.

Term	Description
Transmitter	The device that transmits data to the bus.
Receiver	The device that receives data from the bus.
Master	The device that initiates a transfer, generates clock signals, and terminates a transfer.
Slave	The device addressed by the Master.

Table 8. Serial Interface Terminologies

I²C Serial Interface

As previously mentioned, the KXCJ9 has the ability to communicate on an I²C bus. I²C is primarily used for synchronous serial communication between a Master device and one or more Slave devices. The Master, typically a micro controller, provides the serial clock signal and addresses Slave devices on the bus. The KXCJ9 always operates as a Slave device during standard Master-Slave I²C operation.

I²C is a two-wire serial interface that contains a Serial Clock (SCL) line and a Serial Data (SDA) line. SCL is a serial clock that is provided by the Master, but can be held low by any Slave device, putting the Master into a wait condition. SDA is a bi-directional line used to transmit and receive data to and from the interface. Data is transmitted MSB (Most Significant Bit) first in 8-bit per byte format, and the number of bytes transmitted per transfer is unlimited. The I²C bus is considered free when both lines are high. The I²C interface is compliant with high-speed mode, fast mode and standard mode I²C standards.



± 4g / 8g / 16g Tri-axis Digital Accelerometer Specifications

PART NUMBER:

KXCJ9-1018
Rev. 2
Sep-2014

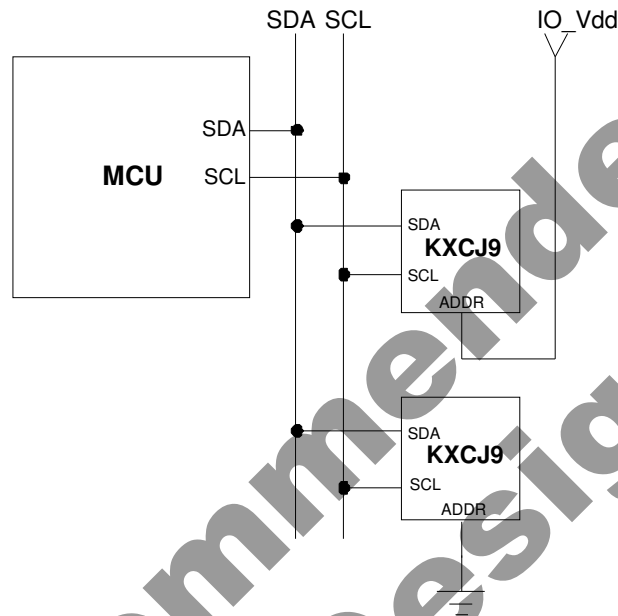

Figure 1. Multiple KXCJ9 I²C Connection

I²C Operation

Transactions on the I²C bus begin after the Master transmits a start condition (S), which is defined as a high-to-low transition on the data line while the SCL line is held high. The bus is considered busy after this condition. The next byte of data transmitted after the start condition contains the Slave Address (SAD) in the seven MSBs (Most Significant Bits), and the LSB (Least Significant Bit) tells whether the Master will be receiving data '1' from the Slave or transmitting data '0' to the Slave. When a Slave Address is sent, each device on the bus compares the seven MSBs with its internally stored address. If they match, the device considers itself addressed by the Master. The KXCJ9's Slave Address is comprised of a programmable part and a fixed part, which allows for connection of multiple KXCJ9's to the same I²C bus. The Slave Address associated with the KXCJ9 is 000111X, where the programmable bit, X, is determined by the assignment of ADDR (pin 8) to GND or IO_Vdd. Figure 1 above shows how two KXCJ9's would be implemented on an I²C bus.

It is mandatory that receiving devices acknowledge (ACK) each transaction. Therefore, the transmitter must release the SDA line during this ACK pulse. The receiver then pulls the data line low so that it remains stable low during the high period of the ACK clock pulse. A receiver that has been addressed, whether it is Master or Slave, is obliged to generate an ACK after each byte of data has been received. To conclude a transaction, the Master must transmit a stop condition (P) by transitioning the SDA line from low to high while SCL is high. The I²C bus is now free.



± 4g / 8g / 16g Tri-axis Digital Accelerometer Specifications

PART NUMBER:

KXCJ9-1018
Rev. 2
Sep-2014

Writing to a KXCJ9 8-bit Register

Upon power up, the Master must write to the KXCJ9's control registers to set its operational mode. Therefore, when writing to a control register on the I²C bus, as shown Sequence 1 on the following page, the following protocol must be observed: After a start condition, SAD+W transmission, and the KXCJ9 ACK has been returned, an 8-bit Register Address (RA) command is transmitted by the Master. This command is telling the KXCJ9 to which 8-bit register the Master will be writing the data. Since this is I²C mode, the MSB of the RA command should always be zero (0). The KXCJ9 acknowledges the RA and the Master transmits the data to be stored in the 8-bit register. The KXCJ9 acknowledges that it has received the data and the Master transmits a stop condition (P) to end the data transfer. The data sent to the KXCJ9 is now stored in the appropriate register. The KXCJ9 automatically increments the received RA commands and, therefore, multiple bytes of data can be written to sequential registers after each Slave ACK as shown in Sequence 2 on the following page.

Reading from a KXCJ9 8-bit Register

When reading data from a KXCJ9 8-bit register on the I²C bus, as shown in Sequence 3 on the next page, the following protocol must be observed: The Master first transmits a start condition (S) and the appropriate Slave Address (SAD) with the LSB set at '0' to write. The KXCJ9 acknowledges and the Master transmits the 8-bit RA of the register it wants to read. The KXCJ9 again acknowledges, and the Master transmits a repeated start condition (Sr). After the repeated start condition, the Master addresses the KXCJ9 with a '1' in the LSB (SAD+R) to read from the previously selected register. The Slave then acknowledges and transmits the data from the requested register. The Master does not acknowledge (NACK) it received the transmitted data, but transmits a stop condition to end the data transfer. Note that the KXCJ9 automatically increments through its sequential registers, allowing data to be read from multiple registers following a single SAD+R command as shown below in Sequence 4 on the following page. The 8-bit register data is transmitted using a left-most format, first bit shifted/clocked out being the MSB bit.

If a receiver cannot transmit or receive another complete byte of data until it has performed some other function, it can hold SCL low to force the transmitter into a wait state. Data transfer only continues when the receiver is ready for another byte and releases SCL.



± 4g / 8g / 16g Tri-axis Digital Accelerometer Specifications

PART NUMBER:

**KXCJ9-1018
Rev. 2
Sep-2014**

Data Transfer Sequences

The following information clearly illustrates the variety of data transfers that can occur on the I²C bus and how the Master and Slave interact during these transfers. Table 9 defines the I²C terms used during the data transfers.

Term	Definition
S	Start Condition
Sr	Repeated Start Condition
SAD	Slave Address
W	Write Bit
R	Read Bit
ACK	Acknowledge
NACK	Not Acknowledge
RA	Register Address
Data	Transmitted/Received Data
P	Stop Condition

Table 9. I²C Terms

Sequence 1. The Master is writing one byte to the Slave.

Master	S	SAD + W		RA		DATA		P
Slave			ACK		ACK			ACK

Sequence 2. The Master is writing multiple bytes to the Slave.

Master	S	SAD + W		RA		DATA		DATA		P
Slave			ACK		ACK		ACK		ACK	

Sequence 3. The Master is receiving one byte of data from the Slave.

Master	S	SAD + W		RA		Sr	SAD + R			NACK	P
Slave			ACK		ACK			ACK	DATA		

Sequence 4. The Master is receiving multiple bytes of data from the Slave.

Master	S	SAD + W		RA		Sr	SAD + R			ACK		NACK	P
Slave			ACK		ACK			ACK	DATA		DATA		



± 4g / 8g / 16g Tri-axis Digital Accelerometer Specifications

PART NUMBER:

**KXCJ9-1018
Rev. 2
Sep-2014**

KXCJ9 Embedded Registers

The KXCJ9 has 25 embedded 8-bit registers that are accessible by the user. This section contains the addresses for all embedded registers and also describes bit functions of each register. Table 10 below provides a listing of the accessible 8-bit registers and their addresses.

Register Name	Type Read/Write	I2C Address	
		Hex	Binary
Kionix Reserved	-	0x00 – 0x05	-
XOUT_L	R	0x06	0000 0110
XOUT_H	R	0x07	0000 0111
YOUT_L	R	0x08	0000 1000
YOUT_H	R	0x09	0000 1001
ZOUT_L	R	0x0A	0000 1010
ZOUT_H	R	0x0B	0000 1011
DCST_RESP	R	0x0C	0000 1100
Kionix Reserved	-	0x0D – 0x0E	-
WHO_AM_I	R	0x0F	0000 1111
Kionix Reserved	-	0x10 – 0x15	-
INT_SOURCE1	R	0x16	0001 0110
INT_SOURCE2	R	0x17	0001 0111
STATUS_REG	R	0x18	0001 1000
Kionix Reserved	-	0x19	-
INT_REL	R	0x1A	0001 1010
CTRL_REG1*	R/W	0x1B	0001 1011
Kionix Reserved	-	0x1C	0001 1100
CTRL_REG2*	R/W	0x1D	0001 1101
INT_CTRL_REG1*	R/W	0x1E	0001 1110
INT_CTRL_REG2*	R/W	0x1F	0001 1111
Kionix Reserved	-	0x20	0010 0000
DATA_CTRL_REG*	R/W	0x21	0010 0001
Kionix Reserved	-	0x22 – 0x28	-
WAKEUP_TIMER*	R/W	0x29	0010 1001
Kionix Reserved	-	0x2A – 0x39	-
SELF_TEST	R/W	0x3A	0011 1010
Kionix Reserved	-	0x3B – 0x69	-
WAKUP_THRESHOLD*	R/W	0x6A	0110 1010

* Note: When changing the contents of these registers, the PC1 bit in CTRL_REG1 must first be set to "0".

Table 10. KXCJ9 Register Map



± 4g / 8g / 16g Tri-axis Digital Accelerometer Specifications

PART NUMBER:

**KXCJ9-1018
Rev. 2
Sep-2014**

KXCJ9 Register Descriptions

Accelerometer Outputs

These registers contain up to 12-bits of valid acceleration data for each axis depending on the setting of the RES bit in CTRL_REG1, where the acceleration outputs are represented in 12-bit valid data when RES = '1' and 8-bit valid data when RES = '0'. The data is updated every user-defined ODR period, is protected from overwrite during each read, and can be converted from digital counts to acceleration (g) per Table 11 below. The register acceleration output binary data is represented in 2's complement format. For example, if N = 12 bits, then the Counts range is from -2048 to 2047, and if N = 8 bits, then the Counts range is from -128 to 127.

12-bit Register Data (2's complement)	Equivalent Counts in decimal	Range = +/-4g	Range = +/-8g	Range = +/-16g
0111 1111 1111	2047	+3.998g	+7.996g	+15.992g
0111 1111 1110	2046	+3.996g	+7.992g	+15.984g
...
0000 0000 0001	1	+0.002g	+0.004g	+0.008g
0000 0000 0000	0	0.000g	0.000g	...
1111 1111 1111	-1	-0.002g	-0.004g	-0.008g
...
1000 0000 0001	-2047	-3.998g	-7.996g	-15.992g
1000 0000 0000	-2048	-4.000g	-8.000g	-16.000g

8-bit Register Data (2's complement)	Equivalent Counts in decimal	Range = +/-4g	Range = +/-8g	Range = +/-16g
0111 1111	127	+3.968g	+7.936g	+15.872g
0111 1110	126	+3.936g	+7.872g	+15.744g
...
0000 0001	1	+0.032g	+0.064g	+0.128g
0000 0000	0	0.000g	0.000g	...
1111 1111	-1	-0.032g	-0.064g	-0.128g
...
1000 0001	-127	-3.968g	-7.936g	-15.872g
1000 0000	-128	-4.000g	-8.000g	-16.000g

Table 11. Acceleration (g) Calculation



± 4g / 8g / 16g Tri-axis Digital Accelerometer Specifications

PART NUMBER:

KXCJ9-1018
Rev. 2
Sep-2014

XOUT_L

X-axis accelerometer output least significant byte

R	R	R	R	R	R	R	R
XOUTD3	XOUTD2	XOUTD1	XOUTD0	X	X	X	X
Bit7	Bit6	Bit5	Bit4	Bit3	Bit2	Bit1	Bit0
I ² C Address: 0x06h							

XOUT_H

X-axis accelerometer output most significant byte

R	R	R	R	R	R	R	R
XOUTD11	XOUTD10	XOUTD9	XOUTD8	XOUTD7	XOUTD6	XOUTD5	XOUTD4
Bit7	Bit6	Bit5	Bit4	Bit3	Bit2	Bit1	Bit0
I ² C Address: 0x07h							

YOUT_L

Y-axis accelerometer output least significant byte

R	R	R	R	R	R	R	R
YOUTD3	YOUTD2	YOUTD1	YOUTD0	X	X	X	X
Bit7	Bit6	Bit5	Bit4	Bit3	Bit2	Bit1	Bit0
I ² C Address: 0x08h							

YOUT_H

Y-axis accelerometer output most significant byte

R	R	R	R	R	R	R	R
YOUTD11	YOUTD10	YOUTD9	YOUTD8	YOUTD7	YOUTD6	YOUTD5	YOUTD4
Bit7	Bit6	Bit5	Bit4	Bit3	Bit2	Bit1	Bit0
I ² C Address: 0x09h							



± 4g / 8g / 16g Tri-axis Digital Accelerometer Specifications

PART NUMBER:

**KXCJ9-1018
Rev. 2
Sep-2014**

ZOUT_L

Z-axis accelerometer output least significant byte

R	R	R	R	R	R	R	R
ZOUTD3	ZOUTD2	ZOUTD1	ZOUTD0	X	X	X	X
Bit7	Bit6	Bit5	Bit4	Bit3	Bit2	Bit1	Bit0
I ² C Address: 0x0Ah							

ZOUT_H

Z-axis accelerometer output most significant byte

R	R	R	R	R	R	R	R
ZOUTD11	ZOUTD10	ZOUTD9	ZOUTD8	ZOUTD7	ZOUTD6	ZOUTD5	ZOUTD4
Bit7	Bit6	Bit5	Bit4	Bit3	Bit2	Bit1	Bit0
I ² C Address: 0x0Bh							

Not Recommended for New Designs



± 4g / 8g / 16g Tri-axis Digital Accelerometer Specifications

PART NUMBER:

**KXCJ9-1018
Rev. 2
Sep-2014**

DCST_RESP

This register can be used to verify proper integrated circuit functionality. It always has a byte value of 0x55h unless the DCST bit in CTRL_REG3 is set. At that point this value is set to 0xAAh. The byte value is returned to 0x55h after reading this register.

R	R	R	R	R	R	R	R	
DCSTR7	DCSTR6	DCSTR5	DCSTR4	DCSTR3	DCSTR2	DCSTR1	DCSTR0	Reset Value
Bit7	Bit6	Bit5	Bit4	Bit3	Bit2	Bit1	Bit0	01010101
I ² C Address: 0x0Ch								

WHO_AM_I

This register can be used for supplier recognition, as it can be factory written to a known byte value. The default value is 0x1Dh.

R	R	R	R	R	R	R	R	
WIA7	WIA6	WIA5	WIA4	WIA3	WIA2	WIA1	WIA0	Reset Value
Bit7	Bit6	Bit5	Bit4	Bit3	Bit2	Bit1	Bit0	00011101
I ² C Address: 0x0Fh								



± 4g / 8g / 16g Tri-axis Digital Accelerometer Specifications

PART NUMBER:

**KXCJ9-1018
Rev. 2
Sep-2014**

Interrupt Source Registers

These two registers report interrupt state changes. This data is updated when a new interrupt event occurs and each application's result is latched until the interrupt release register is read. The programmable interrupt engine can be configured to report data in an unlatched manner via the interrupt control registers.

INT_SOURCE1

This register reports which function caused an interrupt. Reading from the interrupt release register (INT_REL, 0x1Ah) will clear the entire contents of this register.

R	R	R	R	R	R	R	R
0	0	0	DRDY	0	0	WUFS	0
Bit7	Bit6	Bit5	Bit4	Bit3	Bit2	Bit1	Bit0
I ² C Address: 0x16h							

DRDY - indicates that new acceleration data (at Reg Addr 0x06h to 0x0Bh) is available. This bit is cleared when acceleration data is read or the interrupt release register (INT_REL, 0x1Ah) is read.

- 0 = New acceleration data not available
- 1 = New acceleration data available

WUFS - Wake up, This bit is cleared when the interrupt source latch register (INT_REL, 0x1Ah) is read.

- 0 = No motion
- 1 = Motion has activated the interrupt



± 4g / 8g / 16g Tri-axis Digital Accelerometer Specifications

PART NUMBER:

**KXCJ9-1018
Rev. 2
Sep-2014**

INT_SOURCE2

This register reports the axis and direction of detected motion per Table 12. This register is cleared when the interrupt source latch register (INT_REL, 0x1Ah) is read.

R	R	R	R	R	R	R	R
0	0	XNWU	XPWU	YNWU	YPWU	ZNWU	ZPWU
Bit7	Bit6	Bit5	Bit4	Bit3	Bit2	Bit1	Bit0
I ² C Address: 0x17h							

Bit	Description
XNWU	X Negative (X-) Reported
XPWU	X Positive (X+) Reported
YNWU	Y Negative (Y-) Reported
YPWU	Y Positive (Y+) Reported
ZNWU	Z Negative (Z-) Reported
ZPWU	Z Positive (Z+) Reported

Table 12. KXCJ9 Motion Reporting



± 4g / 8g / 16g Tri-axis Digital Accelerometer Specifications

PART NUMBER:

**KXCJ9-1018
Rev. 2
Sep-2014**

STATUS_REG

This register reports the status of the interrupt.

R	R	R	R	R	R	R	R
0	0	0	INT	0	0	0	0
Bit7	Bit6	Bit5	Bit4	Bit3	Bit2	Bit1	Bit0
I ² C Address: 0x18h							

INT reports the combined (OR) interrupt information of DRDY and WUFS in the interrupt source register (INT_SOURCE1, 0x16h). This bit is cleared when acceleration data is read or the interrupt release register (INT_REL, 1Ah) is read.

0 = no interrupt event

1 = interrupt event has occurred

INT_REL

Latched interrupt source information (INT_SOURCE1, 0x16h and INT_SOURCE2, 0x17h) is cleared and physical interrupt latched pin (7) is changed to its inactive state when this register is read.

R	R	R	R	R	R	R	R
X	X	X	X	X	X	X	X
Bit7	Bit6	Bit5	Bit4	Bit3	Bit2	Bit1	Bit0
I ² C Address: 0x1Ah							



± 4g / 8g / 16g Tri-axis Digital Accelerometer Specifications

PART NUMBER:

KXCJ9-1018
Rev. 2
Sep-2014

CTRL_REG1

Read/write control register that controls the main feature set.

R/W	R/W	R/W	R/W	R/W	R/W	R/W	R/W	
PC1	RES	DRDYE	GSEL1	GSEL0	0	WUFE	0	Reset Value
Bit7	Bit6	Bit5	Bit4	Bit3	Bit2	Bit1	Bit0	00000000
I ² C Address: 0x1Bh								

PC1 controls the operating mode of the KXCJ9.

- 0 = disabled mode
- 1 = operating mode

RES determines the performance mode of the KXCJ9. Note that to change the value of this bit, the PC1 bit must first be set to "0".

- 0 = low current, 8-bit valid. Only available for ODR ≤ 200 Hz. Bandwidth (Hz) = 800
- 1 = high current, 12-bit or 14-bit valid. Bandwidth (Hz) = ODR/2

DRDYE enables the reporting of the availability of new acceleration data as an interrupt. Note that to change the value of this bit, the PC1 bit must first be set to "0".

- 0 = availability of new acceleration data is not reflected as an interrupt
- 1 = availability of new acceleration data is reflected as an interrupt

GSEL1, GSEL0 selects the acceleration range of the accelerometer outputs per Table 13. Note that to change the value of this bit, the PC1 bit must first be set to "0".

GSEL1	GSEL0	Range
0	0	+/-4g
0	1	+/-8g
1	0	+/-16g
1	1	+/-16g ¹

Table 13. Selected Acceleration Range

WUFE enables the Wake Up (motion detect) function. 0= disabled, 1= enabled. Note that to change the value of this bit, the PC1 bit must first be set to "0".

- 0 = Wake Up function disabled
- 1 = Wake Up function enabled

¹ This is a 14-bit mode available only in Full Power mode and only for Registers 0x06h-0x0Bh



± 4g / 8g / 16g Tri-axis Digital Accelerometer Specifications

PART NUMBER:

**KXCJ9-1018
Rev. 2
Sep-2014**

CTRL_REG2

Read/write control register that provides more feature set control. Note that to properly change the value of this register, the PC1 bit in CTRL_REG1 must first be set to "0".

R/W	R/W	R/W	R/W	R/W	R/W	R/W	R/W	
SRST	reserved	reserved	DCST	reserved	OWUFA	OWUFB	OWUFC	Reset Value
Bit7	Bit6	Bit5	Bit4	Bit3	Bit2	Bit1	Bit0	00000000
I ² C Address: 0x1Dh								

SRST initiates software reset, which performs the RAM reboot routine. This bit will remain 1 until the RAM reboot routine is finished.

SRST = 0 – no action

SRST = 1 – start RAM reboot routine

DCST initiates the digital communication self-test function.

DCST = 0 – no action

DCST = 1 – sets ST_RESP register to 0xAAh and when ST_RESP is read, sets this bit to 0 and sets ST_RESP to 0x55h

OWUFA, OWUFB, OWUFC sets the Output Data Rate for the Wake Up function (motion detection) per Table 14 below

OWUFA	OWUFB	OWUFC	Wake Up function Output Data Rate
0	0	0	0.781Hz
0	0	1	1.563Hz
0	1	0	3.125Hz
0	1	1	6.25Hz
1	0	0	12.5Hz
1	0	1	25Hz
1	1	0	50Hz
1	1	1	100Hz

Table 14. Output Data Rate for Wake Up Function



± 4g / 8g / 16g Tri-axis Digital Accelerometer Specifications

PART NUMBER:

KXCJ9-1018
Rev. 2
Sep-2014

INT_CTRL_REG1

This register controls the settings for the physical interrupt pin (7). Note that to properly change the value of this register, the PC1 bit in CTRL_REG1 must first be set to “0”.

R/W	R/W	R/W	R/W	R/W	R/W	R/W	R/W	
0	0	IEN	IEA	IEL	0	0	0	Reset Value
Bit7	Bit6	Bit5	Bit4	Bit3	Bit2	Bit1	Bit0	00010000
I ² C Address: 0x1Eh								

IEN enables/disables the physical interrupt pin (7)

IEN = 0 – physical interrupt pin (7) is disabled

IEN = 1 – physical interrupt pin (7) is enabled

IEA sets the polarity of the physical interrupt pin (7)

IEA = 0 – polarity of the physical interrupt pin (7) is active low

IEA = 1 – polarity of the physical interrupt pin (7) is active high

IEL sets the response of the physical interrupt pin (7)

IEL = 0 – the physical interrupt pin (7) latches until it is cleared by reading INT_REL

IEL = 1 – the physical interrupt pin (7) will transmit one pulse with a period of 0.03 - 0.05ms

INT_CTRL_REG2

This register controls which axis and direction of detected motion can cause an interrupt. Note that to properly change the value of this register, the PC1 bit in CTRL_REG1 must first be set to “0”.

R/W	R/W	R/W	R/W	R/W	R/W	R/W	R/W	
0	0	XNWUE	XPWUE	YNWUE	YPWUE	ZNWUE	ZPWUE	Reset Value
Bit7	Bit6	Bit5	Bit4	Bit3	Bit2	Bit1	Bit0	00111111
I ² C Address: 0x1Fh								

XNWU - x negative (x-): 0 = disabled, 1 = enabled

XPWU - x positive (x+): 0 = disabled, 1 = enabled

YNWU - y negative (y-): 0 = disabled, 1 = enabled

YPWU - y positive (y+): 0 = disabled, 1 = enabled

ZNWU - z negative (z-): 0 = disabled, 1 = enabled

ZPWU - z positive (z+): 0 = disabled, 1 = enabled



± 4g / 8g / 16g Tri-axis Digital Accelerometer Specifications

PART NUMBER:

**KXCJ9-1018
Rev. 2
Sep-2014**

DATA_CTRL_REG

Read/write control register that configures the acceleration outputs. Note that to properly change the value of this register, the PC1 bit in CTRL_REG1 must first be set to "0".

R/W	R/W	R/W	R/W	R/W	R/W	R/W	R/W	
0	0	0	0	OSAA	OSAB	OSAC	OSAD	Reset Value
Bit7	Bit6	Bit5	Bit4	Bit3	Bit2	Bit1	Bit0	00000010
I ² C Address: 0x21h								

OSAA, OSAB, OSAC, OSAD sets the output data rate (ODR) for the low-pass filtered acceleration outputs per

Table 15.

OSAA	OSAB	OSAC	OSAD	Output Data Rate	LPF Roll-Off
1	0	0	0	0.781Hz	0.3905Hz
1	0	0	1	1.563Hz	0.781Hz
1	0	1	0	3.125Hz	1.563Hz
1	0	1	1	6.25Hz	3.125Hz
0	0	0	0	12.5Hz	6.25Hz
0	0	0	1	25Hz	12.5Hz
0	0	1	0	50Hz	25Hz
0	0	1	1	100Hz	50Hz
0	1	0	0	200Hz	100Hz
0	1	0	1	400Hz	200Hz
0	1	1	0	800Hz	400Hz
0	1	1	1	1600Hz	800Hz

Table 15. Acceleration Output Data Rate (ODR) and LPF Roll-Off

Note: Output Data Rates >= 400Hz will force device into Full Power mode



± 4g / 8g / 16g Tri-axis Digital Accelerometer Specifications

PART NUMBER:

**KXCJ9-1018
Rev. 2
Sep-2014**

WAKEUP_TIMER

This register sets the time motion must be present before a wake-up interrupt is set. Every count is calculated as 1/OWUF delay period. Note that to properly change the value of this register, the PC1 bit in CTRL_REG1 must first be set to "0". Valid Entries are 1 to 255, zero is excluded.

R/W	R/W	R/W	R/W	R/W	R/W	R/W	R/W	
WUFC7	WUFC6	WUFC5	WUFC4	WUFC3	WUFC2	WUFC1	WUFC0	Reset Value
Bit7	Bit6	Bit5	Bit4	Bit3	Bit2	Bit1	Bit0	00000000
I ² C Address: 0x29h								

SELF_TEST

When 0xCA is written to this register, the MEMS self-test function is enabled. Electrostatic-actuation of the accelerometer, results in a DC shift of the X, Y and Z axis outputs. Writing 0x00 to this register will return the accelerometer to normal operation.

R/W	R/W	R/W	R/W	R/W	R/W	R/W	R/W	
1	1	0	0	1	0	1	0	Reset Value
Bit7	Bit6	Bit5	Bit4	Bit3	Bit2	Bit1	Bit0	00000000
I ² C Address: 0x3Ah								

WAKEUP_THRESHOLD

This register sets the threshold for wake-up (motion detect) interrupt is set. The KXCJ9 will ship from the factory with this value set to correspond to a change in acceleration of 0.5g. Note that to properly change the value of this register, the PC1 bit in CTRL_REG1 must first be set to "0".

R/W	R/W	R/W	R/W	R/W	R/W	R/W	R/W	
WUTH7	WUTH6	WUTH5	WUTH4	WUTH3	WUTH2	WUTH1	WUTH0	Reset Value
Bit7	Bit6	Bit5	Bit4	Bit3	Bit2	Bit1	Bit0	00001000
I ² C Address: 0x6Ah								



± 4g / 8g / 16g Tri-axis Digital Accelerometer Specifications

PART NUMBER:

KXCJ9-1018
Rev. 2
Sep-2014

KXCJ9 Embedded Wake Up Function

The KXCJ9 contains an interrupt engine that can be configured by the user to report when qualified changes in acceleration occur. The user has the option to enable or disable specific axes and specific directions, as well as to specify the delay time. An example use case for the engine would be to detect motion on any axis to signal an event and wake up the accelerometer or other devices. This can be achieved by configuring the engine to detect when the acceleration on any axis is greater than the user-defined threshold for a user-defined amount of time. Equations 1 and 2 show how to calculate the engine threshold (WAKEUP_THRESHOLD) and delay time (WAKEUP_TIMER) register values for the desired result.

$$WAKEUP_THRESHOLD \text{ (counts)} = \text{Desired Threshold (g)} \times 8 \text{ (counts/g)}$$

Equation 1. Wake Up Threshold

$$WAKEUP_TIMER \text{ (counts)} = \text{Desired Delay Time (sec)} \times OWUF \text{ (Hz)}$$

Equation 2. Wake Up Delay Time



± 4g / 8g / 16g Tri-axis Digital Accelerometer Specifications

PART NUMBER:

KXCJ9-1018
Rev. 2
Sep-2014

Figure 2 below shows the latched response of the Wake Up Function with WUF Timer = 10 counts.

Typical Wake Up Interrupt Example

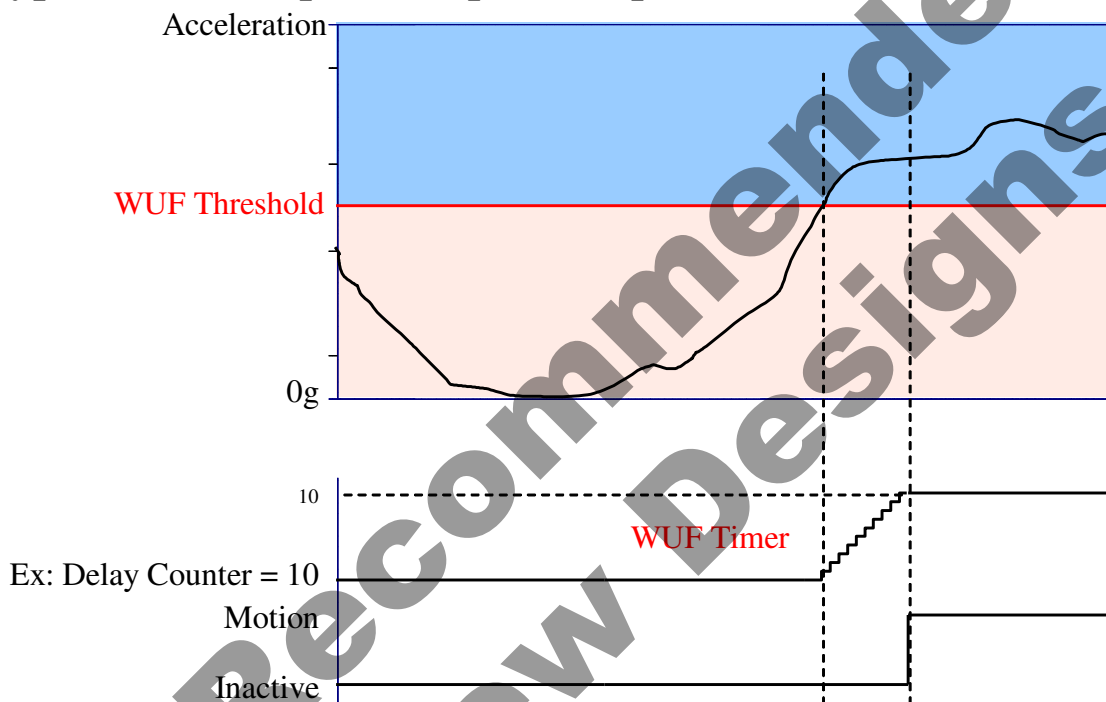

Figure 2. Latched Motion Interrupt Response

The KXCJ9-1018 wake-up function is always latched. However, if the INT_CTRL_REG1 is set with IEL = 1, then upon a wake-up event the WUF interrupt signal will pulse and return low, but only once. The WUF interrupt output will not reset until a read of the INT_REL latch reset register.



± 4g / 8g / 16g Tri-axis Digital Accelerometer Specifications

PART NUMBER:

**KXCJ9-1018
Rev. 2
Sep-2014**

Revision History

REVISION	DESCRIPTION	DATE
1	Initial Production Release	19-Dec-2012
2	revised WHO_AM_I value	12-Sep-2014

"Kionix" is a registered trademark of Kionix, Inc. Products described herein are protected by patents issued or pending. No license is granted by implication or otherwise under any patent or other rights of Kionix. The information contained herein is believed to be accurate and reliable but is not guaranteed. Kionix does not assume responsibility for its use or distribution. Kionix also reserves the right to change product specifications or discontinue this product at any time without prior notice. This publication supersedes and replaces all information previously supplied.