

10 mm GS Sensors

Type: **EVWAE/EVWAD**

Low profile, long life sensor, which is suitable for detecting the angles of rotating axes.

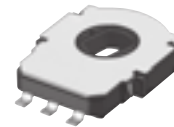

■ Features

- Low profile (H=2.2 mm),
Shaft hole diameters of up to 4 mm are available.
- Long operation life: 1 million operation cycles.
- A wide electrical output angle of a maximum 343 °,
ready for SMDs

■ Recommended Applications

- Detection of robot joint angles
- Detection of air conditioner damper angles
- Detection of various control unit angles

■ Explanation of Part Numbers

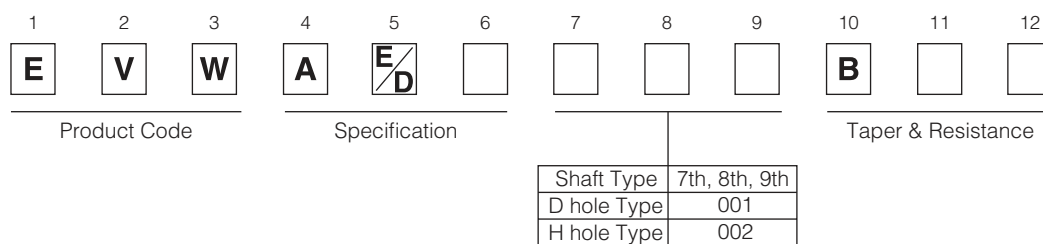

■ Specifications

Mechanical	Rating	0.05 W, 5V
	Operating Force	3 mN·m max.
Electrical	Total Resistance	5 kΩ±30 %, 10 kΩ±30 %
	Linearity	±2 % max.
Endurance	Operating Life	1,000,000 cycles min. (operation Angle ±30°)
Minimum Quantity/Packing Unit		1,500 pcs. Embossed Taping (Reel Pack)
Quantity/Carton		6,000 pcs.

Design and specifications are each subject to change without notice. Ask factory for the current technical specifications before purchase and/or use.
Should a safety concern arise regarding this product, please be sure to contact us immediately.

■ Dimensions in mm (not to scale)

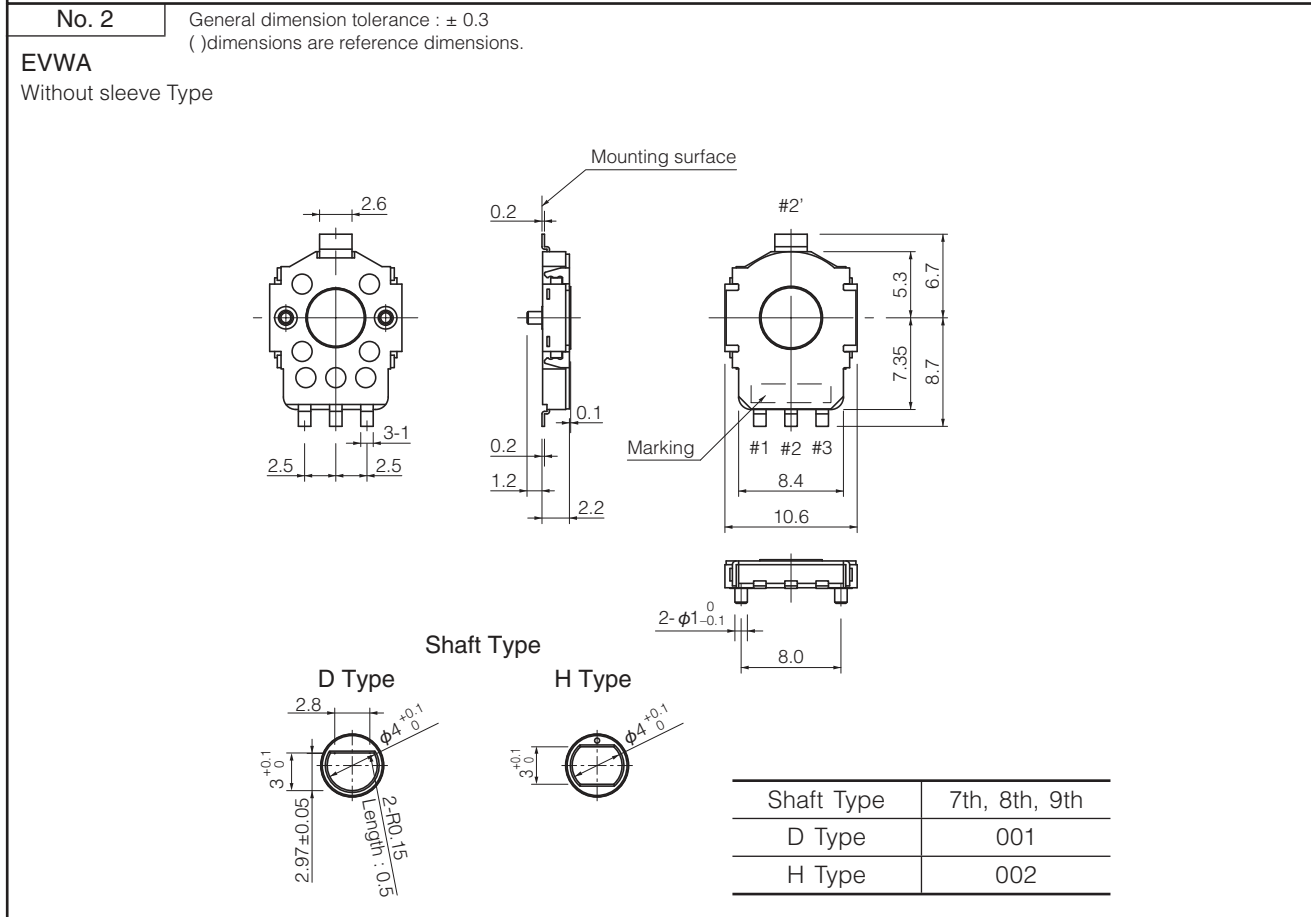
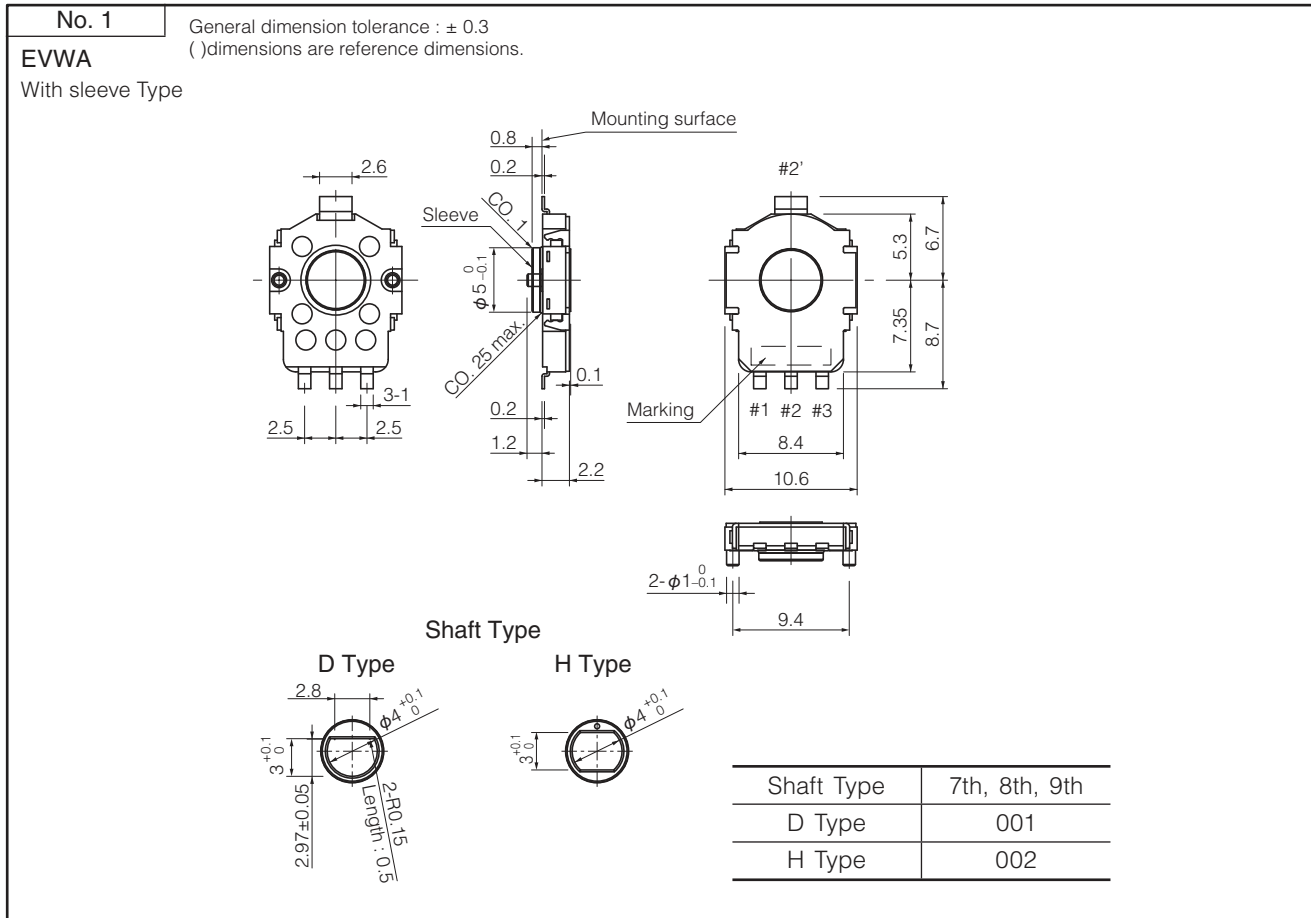

Design and specifications are each subject to change without notice. Ask factory for the current technical specifications before purchase and/or use.
Should a safety concern arise regarding this product, please be sure to contact us immediately.

