

# NOTES: UNLESS OTHERWISE SPECIFIED.

- 1) PART NUMBER CHANGES AND/OR DESIGN CHANGES AFFECTING ITEM INTERCHANGEABILITY REQUIRE PRIOR ELCON APPROVAL AND AUTHORIZATION BY REVISION TO THIS DRAWING.
- 2) ITEMS PROVIDED TO THIS SPECIFICATION TO BE PERMANENTLY IDENTIFIED WITH THE FOLLOWING MINIMUM INFORMATION: PART NUMBER, DATE CODE AND MFG. I.D., CUST. PART NO. 46186A00 & REV. LEVEL 00.
- 3) UNLESS OTHERWISE SPECIFIED, DIMENSIONS ARE IN INCHES. TOLERANCES ARE ANGLES  $\sim \pm 5^\circ$  FRACTIONS  $\sim \pm 1/32$  DECIMALS .XXX  $\sim \pm .005$  AND DECIMALS .XX  $\sim \pm .01$
4. MATERIAL: HOUSING  $\sim$  POLYESTER, 30% G.F., UL 94V-0, GRAY  
 SOCKET BODY  $\sim$  ZINC OR EQUIVALENT.  
 SOCKET ACTIVE ELEMENT  $\sim$  BeCu  
 WIRE  $\sim$  COPPER, #6 AWG, 7/150/36 STRANDING.  
 NEW ENGLAND WIRE #7X150/36TC OR APPRV. EQUIV.  
 TERMINAL  $\sim$  #10, 6 AWG, AMP STYLE #321298 OR EQUIV.  
 SLEEVING  $\sim$  MARKEL "CONFORM-A-SLEEVE" OR EQUIV.
5. FINISH: SOCKET BODY  $\sim$  SILVER PER QQ-S-365, .0002 MIN. OVER  
 NICKEL PER MIL-C-26074, .00004 MIN.  
 SOCKET ACTIVE ELEMENT  $\sim$  SILVER PLATE PER QQ-S-365,  
 .0002 MIN. OVER NICKEL PER  
 QQ-N-290, .00004 MIN.  
 WIRE  $\sim$  TIN COATED

ⓑ

APPROVAL	SF 22MAY06																			
ECO NO.	RELEASED																			
REVISION LETTER	A																			
SHEET NUMBER																				

DRFT. GRZYB.	DATE		P.O. Box 1885 Fremont, California 94538	
	6.28.90			
	CHK.			-
	APPVD.			-
	APPVD.			-
	ACAD FILE NO.			6648216
BACKUP DISK	-	TITLE CUSTOMER USE DRAWING CONNECTOR, SOCKET, BLADE TYPE (2), PD62		
	FSCM NO.	DWG. NO.	SHEET	
	85901	C-6643216	1 OF 3	

6. PERFORMANCE REQUIREMENTS:

CONTACT INSERTION FORCE ~ 4 LBS. MAX. WITH 14 CONTACT ELEMENTS ENGAGED  
 USING A .064 MIN. THICK STEEL BLADE,  
 WITH SURFACE FINISH OF 2-4 MICROINCHES.

ⓑ

CONTACT WITHDRAWAL FORCE ~ 1 LB. MIN WITH 14 CONTACT ELEMENTS ENGAGED  
 USING A .060 MAX. THICK STEEL BLADE,  
 WITH SURFACE FINISH OF 2-4 MICROINCHES.

ⓑ

DURABILITY ~ 50 CYCLES MIN.

CONTACT FLOAT ~ VERTICAL .022 MIN. & HORIZONTAL .015 MIN.

WIRE STRENGTH ~ 100 LBS. MIN. PULL TEST.

WIRE RETENTION FORCE ~ BODY/WIRE/LUG 100 LBS. PULL TEST.

INSERTION TEST BLADE ~ .928 MIN. (SEE DETAIL A).

CONTACT DEFLECTION (14 CONTACT ELEMENTS) ~  $\leq .004$

ELECTRICAL (22° ± 3° C)

CONTACT CURRENT RATING ~ 125A AT 30° C MAX. TEMP. RISE.

CONNECTOR VOLTAGE DROP ~ 125A WITH .060 MAX. THICK COPPER BLADE,  
 SILVER PLATED, .0002 (14 CONTACT ELEMENTS)

V1 = 10.6 mV MAX. V2 = 28 mV MAX.

(SEE DETAIL B)

CONTACT RESISTANCE ~ TBD

CONTACT ELEMENT RATING ~ 12.5A MAX. (SEE DETAIL B).

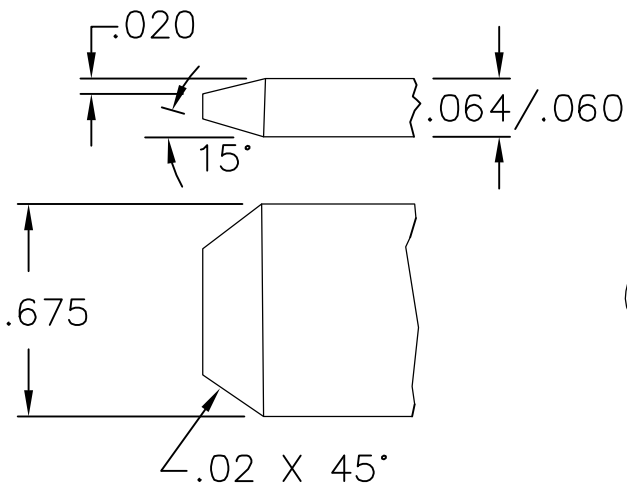

DETAIL A

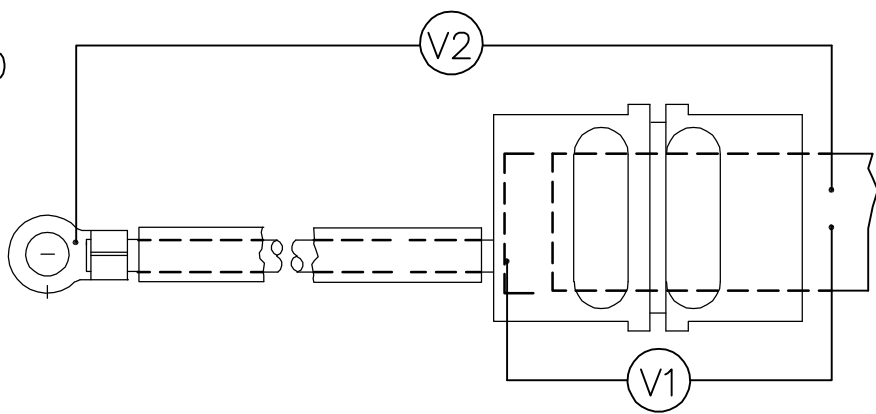

DETAIL B

REVISION: A	DRFT. GRZYB.	DATE 22MAY06	 P.O. Box 1885 Fremont, California 94538	
	CHK. -	-		
	APPVD. -	-	TITLE CUSTOMER USE DRAWING CONNECTOR, SOCKET, BLADE TYPE (2), PD62	
	APPVD. -	-		
	ACAD FILE NO. 6648216	FSCM NO. 85901	DWG. NO. C-6643216	SHEET 2 OF 3
	BACKUP DISK -	-	-	-

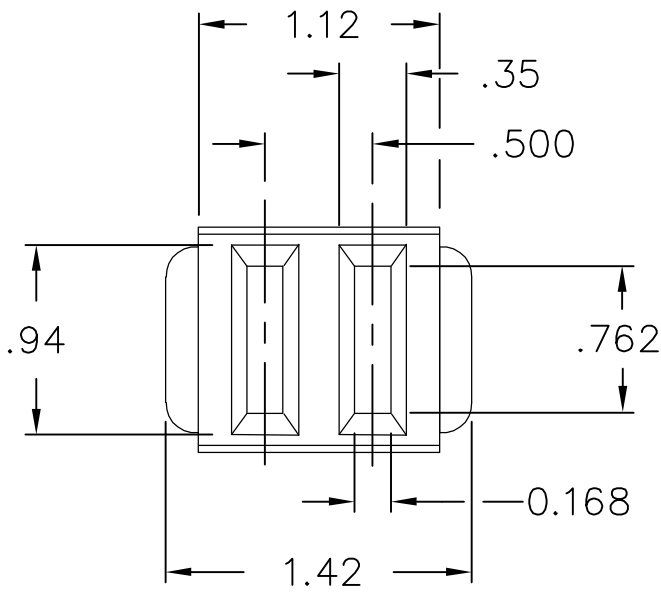

← VERTICAL DIRECTION →

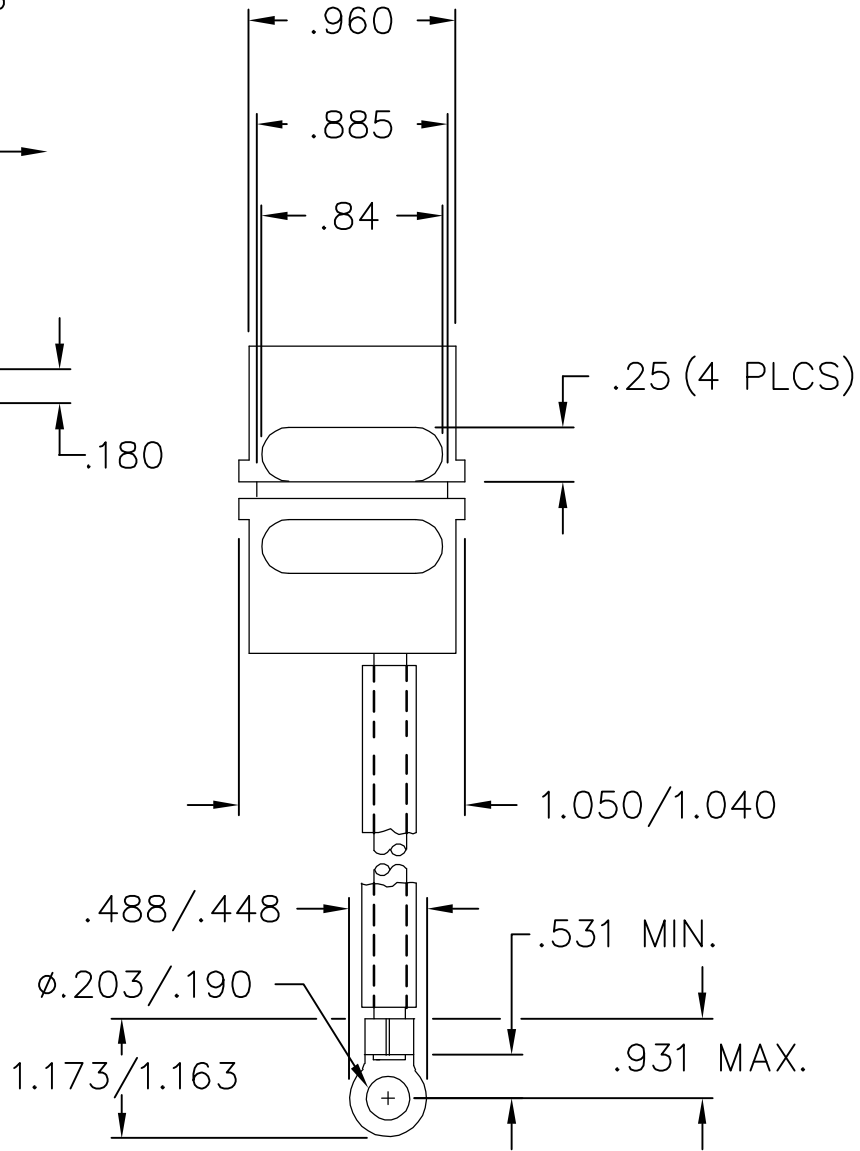
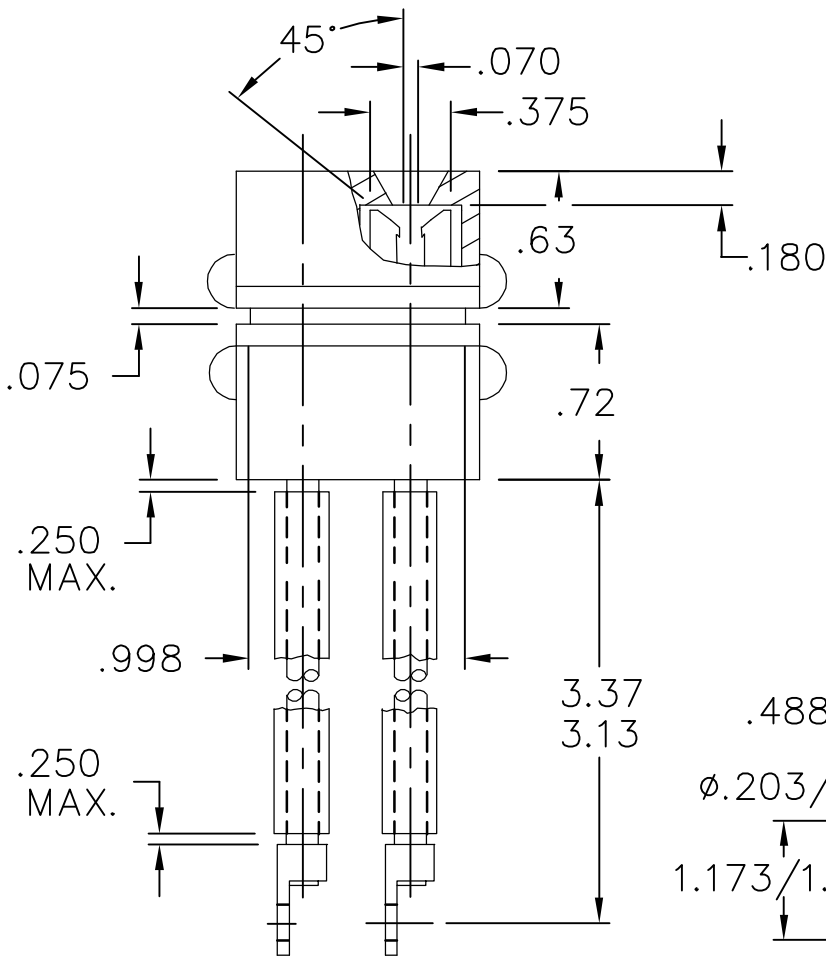

DRFT. GRZYB.	DATE 22MAY06
CHK. -	-
APPVD. -	-
APPVD. -	-
ACAD FILE NO. 6648216	
BACKUP DISK -	



P.O. Box 1885  
Fremont, California  
94538

TITLE CUSTOMER USE DRAWING  
CONNECTOR, SOCKET, BLADE  
TYPE (2), PD62

FSCM NO. 85901	DWG. NO. C-6643216	SHEET 3 OF 3
-------------------	-----------------------	-----------------

REVISION: A