

Features

- High power density up to 120W
- Open-frame packaging
- 100°C base plate operation
- Water washable
- Outputs from 2.5V to 15V
- 1500V isolation
- Positive or negative enable logic

Description

QBS single output dc-dc converters provide up to 120 watts of output power in an industry-standard, quarter-brick footprint. The QBS converters feature open-frame packaging, along with planar magnetics to provide maximum useable power with minimal thermal constraints. The QBS is especially suited to telecom, networking, and industrial applications, and is fully compatible with production board washing processes.

Technical Specifications

Input	
Voltage Range	18 - 36 VDC
24 VDC Nominal	18 - 36 VDC
48 VDC Nominal	36 - 75 VDC
Input Reverse Voltage Protection	Shunt Diode

Output	
Setpoint Accuracy	± 1%
Line Regulation V_{in} Min. - V_{in} Max., I_{out} Rated	0.2% V_{out}
Load Regulation I_{out} Min. - I_{out} Max., V_{in} Nom.	0.5% V_{out}
Remote Sense Headroom	0.5 VDC
Minimum Output Current	10 % I_{out} Rated
Dynamic Regulation, Loadstep	25% I_{out}
Pk Deviation	4% V_{out}
Settling Time	500 m s
Voltage Trim Range	± 10%
Short Circuit And Overcurrent Protection	Shutdown
Current Limit Threshold Range, % of I_{out} Rated	110 - 140%
Short Circuit Current Limit	200% I_{out} OVP Trip
Range	115 - 140% V_{out} Nom.
UVP Trip Range	70 - 90% V_{out} Nom.
OVP/UVP Type	Latching

General	
Turn-On Time	30 ms
Remote Shutdown	Positive or Negative Logic
Remote Shutdown Reference	V_{in} Negative
Switching Frequency	400 kHz
Isolation	
Input - Output	1500 VDC
Input - Case	1050 VDC
Output - Case	1050 VDC
Temperature Coefficient	0.02 ppm/°C
Case Temperature	
Operating Range	-40°C To +100°C
Storage Range	-40°C To +125°C
Thermal Shutdown Range	105°C To 115°C
Vibration, 3 Axes, 5 Min Each	5 g, 10 - 55 Hz
MTBF† (Bellcore TR-NWT-000332)	2.5 X 10 ⁶ hrs
Safety	UL, cUL, TUV
Weight (Approx.)	1.7 oz

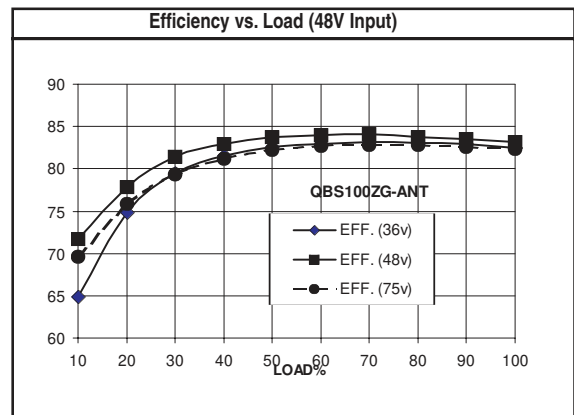

Notes
† MTBF predictions may vary slightly from model to model.
Specifications typically at 25°C, normal line, and full load, unless otherwise stated.
Soldering Conditions: I/O pins, 260°C, ten seconds; fully compatible with commercial wave-soldering equipment.
Safety: Agency approvals may vary from model to model. Please consult factory for specific model information.
Units are water-washable and fully compatible with commercial spray or immersion post wave-solder washing equipment.

Model Selection

MODEL	INPUT VOLTAGE (VOLTS)	INPUT VOLTAGE RANGE (VOLTS)	MAXIMUM INPUT CURRENT (AMPS)*	OUTPUT VOLTAGE (VOLTS)	RATED OUTPUT CURRENT (AMPS)	RIPPLE & NOISE pk-pk (mV)	TYPICAL EFFICIENCY**
QBS038YD-A	24	18 - 36	2.90	2.5	15.00	100	76%
QBS050YE-A	24	18 - 36	3.50	3.3	15.00	100	80%
QBS075YG-A	24	18 - 36	5.20	5	15.00	100	84%
QBS100YH-A	24	18 - 36	6.80	12	8.33	150	85%
QBS100YJ-A	24	18 - 36	6.80	15	6.67	150	85%
QBS038ZD-A	48	36 - 75	1.40	2.5	15.00	100	75%
QBS050ZE-A	48	36 - 75	1.70	3.3	15.00	100	78%
QBS075ZG-A	48	36 - 75	2.50	5	15.00	100	83%
QBS100ZH-A	48	36 - 75	3.30	12	8.33	150	86%
QBS120ZH-A	48	36 - 75	4.00	12	10.00	150	84%
QBS100ZJ-A	48	36 - 75	3.30	15	6.67	150	86%
QBS066ZE-A	48	36 - 75	2.50	3.3	20.0	100	80%
QBS100ZG-A	48	36 - 75	3.45	5	20.0	100	82%
QBS120ZJ-A	48	36 - 75	4.00	15	8.0	150	84%

NOTES:

- * Maximum input current at minimum input voltage, maximum rated output power.
- ** At nominal V_{in} , rated output.

Model numbers highlighted in yellow or shaded are not recommended for new designs.

Mechanical Drawing

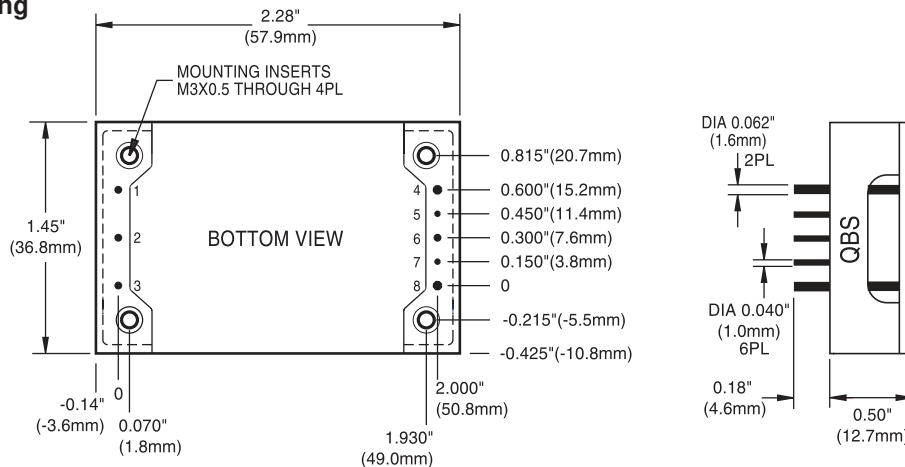

Thermal Impedance	
Natural Convection	10.1 °C/W
100 LFM	8.0 °C/W
200 LFM	5.4 °C/W
300 LFM	4.4 °C/W
400 LFM	3.4 °C/W

Note:
Thermal impedance data is dependent on many environmental factors. The exact thermal performance should be validated for specific application.

Pin	Function
1	- V_{in}
2	On/Off
3	+ V_{in}
4	- V_{out}
5	-Sense
6	Trim
7	+Sense
8	+ V_{out}

Tolerances	
Inches:	(Millimeters)
.XX ± 0.020	.X ± 0.5
.XXX ± .010	.XX ± 0.25
Pin:	
± 0.002	± 0.05
(Dimensions as listed unless otherwise specified.)	

NUCLEAR AND MEDICAL APPLICATIONS - Power-One products are not authorized for use as critical components in life support systems, equipment used in hazardous environments, or nuclear control systems without the express written consent of the respective divisional president of Power-One, Inc.

TECHNICAL REVISIONS - The appearance of products, including safety agency certifications pictured on labels, may change depending on the date manufactured. Specifications are subject to change without notice.