

E5 Features

- Quick, simple assembly, and disassembly
- Rugged screw-together housing
- Positive latching connector
- Accepts .010 in. axial shaft play
- 32 to 5,000 cycles per revolution (CPR)
- 128 to 20,000 pulses per revolution (PPR)
- 2 channel quadrature TTL squarewave outputs
- Optional index (3rd channel)
- Mounting compatibility with HEDS-5500



E5 Product Description

The E5 Series rotary encoder has a rugged glass-filled polymer enclosure with either a 5-pin or 10-pin latching connector. This optical incremental encoder is designed to easily mount to and dismount from an existing motor shaft to provide digital feedback information.



The internal components consist of a mylar disk mounted to a precision machined aluminum hub and an encoder module. The module contains a highly collimated solid-state light source and monolithic phased array sensor, which together provide a system extremely tolerant to mechanical misalignment.

The single-ended output version (S-option) is typically used with cables of 10 feet or less. For longer cable lengths, the differential output version (D-option) is recommended.

Attachment of the base to a surface may be accomplished by utilizing several machine screw bolt circle options. Positioning of the base to the centerline of a shaft is ensured by using a centering tool (sold separately). The cover is securely attached to the base with two 4-40 flat head screws to provide a resilient package protecting the internal components.

A secure connection to the E5 Series encoder is made through a 5-pin (single-ended versions) or 10-pin (differential versions) latching connector. The mating connectors are available from US Digital with several cable options and lengths.

BROADCOM/AVAGO REPLACEMENTS:

US Digital's E5 encoder may be used as a replacement for Avago HEDL-5500, HEDL-5600

(<https://www.usdigital.com/support/resources/reference/compatibility-guides/avago-compatibility-hedl-5xxx/>).

Mechanical Drawings

E5 Single-Ended Optical Kit Encoder (Default)

RELEASE DATE: 1/7/2020

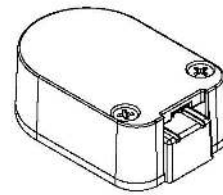
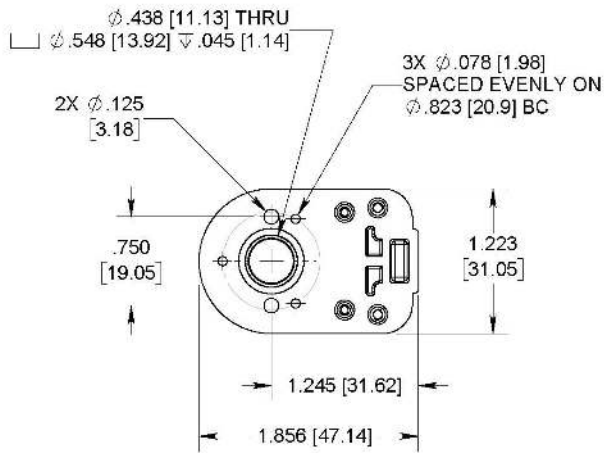
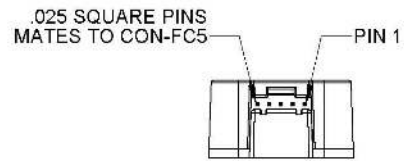
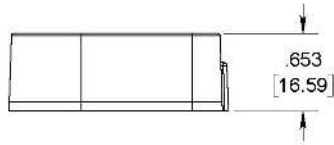

US DIGITAL 1400 NE 136th Avenue
Vancouver, Washington 98684, USA

info@usdigital.com
www.usdigital.com

Local: 360.260.2468
Toll-free: 800.736.0194

UNITS: INCHES [MM]
METRIC SHOWN FOR REFERENCE ONLY

E5 Optical Kit Encoder Base & Cover Options

E-OPTION COVER
(EXTENSION FOR SHAFT
LENGTHS UP TO .750 [19.05])

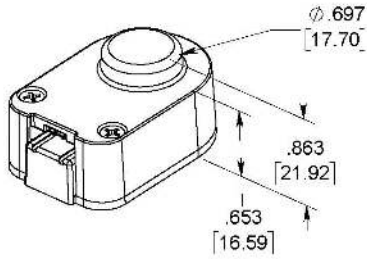

H-OPTION COVER
(COVER HOLE FOR SHAFT
LENGTHS OVER .750 [19.05])

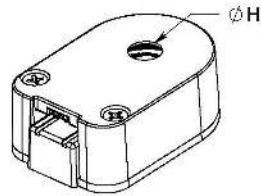

H = .295 [7.49] FOR SHAFT SIZES $\leq \phi .250$ [6.35]
H = .438 [11.13] FOR SHAFT SIZES $> \phi .250$ [6.35]

3-OPTION BASE
(LARGER MOUNTING HOLES)

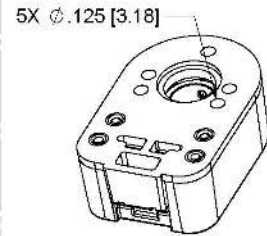

RELEASE DATE: 1/7/2020

A-OPTION BASE
(ALIGNMENT BOSS)

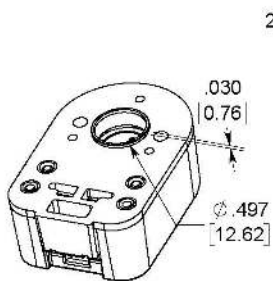

G-OPTION BASE
(1.812" MOUNTING)

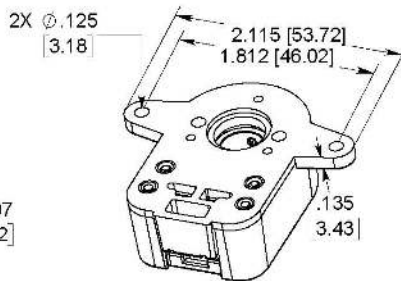

R-OPTION BASE
(ROTATIONAL MOUNTING)

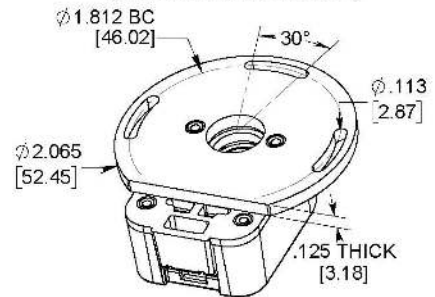

REQUIRES ADDITIONAL .125 [3.18] SHAFT LENGTH

US DIGITAL 1400 NE 136th Avenue
Vancouver, Washington 98684, USA

info@usdigital.com
www.usdigital.com

Local: 360.260.2468
Toll-free: 800.736.0194

UNITS: INCHES [MM]
METRIC SHOWN FOR REFERENCE ONLY

E5 Differential Optical Kit Encoder (Default)

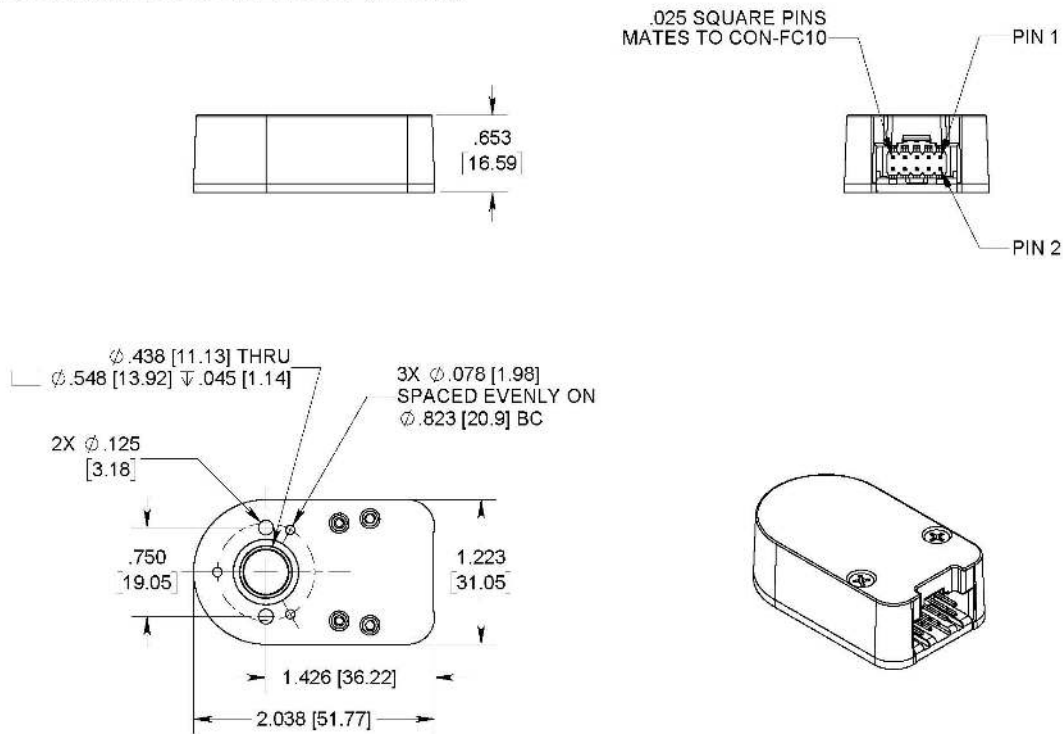

RELEASE DATE: 1/7/2020

US DIGITAL
1400 NE 136th Avenue
Vancouver, Washington 98684, USA

info@usdigital.com
www.usdigital.com

Local: 360.260.2468
Toll-free: 800.736.0194

UNITS: INCHES [MM]
METRIC SHOWN FOR REFERENCE ONLY

Specifications

ENVIRONMENTAL

Parameter	Value	Units
Operating Temperature, CPR < 2000	-40 to 100	C
Operating Temperature, CPR ≥ 2000	-25 to 100	C
Vibration (5Hz to 2kHz)	20	G
Electrostatic Discharge		
Single-ended (-S version), IEC 61000-4-2	± 4	kV
Differential (-D, -L version), Human Body Model	± 2	

MECHANICAL



E5 OPTICAL KIT ENCODER

PARAMETER	VALUE	UNITS
Max. Shaft Axial Play	±0.010	in.
Max. Shaft Runout	0.004 T.I.R.	in.
Max. Acceleration	250000	rad/sec ²
For CPR < 2000 Max. RPM (1) (300 kHz) e.x. CPR=1250, max. rpm=14400 e.x. CPR=100, max. rpm=60000	minimum value of $((18 \times 10^6) / \text{CPR})$ and (60000)	rpm
For CPR ≥ 2000 and < 4000 Max. RPM (1) (360 kHz)	minimum value of $((21.6 \times 10^6) / \text{CPR})$ and (60000)	rpm
For CPR ≥ 4000 Max. RPM (1) (720 kHz)	minimum value of $((43.2 \times 10^6) / \text{CPR})$ and (60000)	rpm
Typical Product Weight Single-ended (S-option) Differential (D-option, L-option)	0.82 0.91	oz.
Codewheel Moment of Inertia	8.0×10^{-6}	oz-in-s ²
Hub Set Screw	#4-48	
Hex Wrench Size	0.050	in.
Encoder Base Plate Thickness	0.135	in.
3 Mounting Screw Size	#0-80	
2 Mounting Screw Size	#2-56 or #4-40	
3 Screw Bolt Circle Diameter	0.823 ± 0.005	in.
2 Screw Bolt Circle Diameter	0.750 ± 0.005	in.
Required Shaft Length (2) With E-option (2) With H-option (2)	0.445 to 0.570 0.445 to 0.750 > 0.445	in.
Index Alignment to Hub Set Screw	180 Typical	degrees
Technical Bulletin TB1001 - Shaft and Bore Tolerances		Download https://www.usdigital.com/media/yyvb4qsy/tb_1001.pdf

(1) 60000 rpm is the maximum rpm due to mechanical considerations. The maximum RPM due to the module's maximum frequency response is dependent upon the module's resolution (CPR). For resolutions of 32 to 1999 CPR the frequency response is 300 kHz, 2000 to 3999 CPR the frequency response is 360 kHz and 4000 CPR and greater the frequency response is 720 kHz.

(2) Add 0.125" to the required shaft length when using **R**-option.

TORQUE SPECIFICATIONS

PARAMETER	VALUE	TORQUE
Hub Set Screw	2-3	in-lbs
Cover Screw	2-4	in-lbs
Base Mounting Screw (#0-80)	1-2	in-lbs
Base Mounting Screw (#2-56)	2-3	in-lbs
Base Mounting Screw (#4-40)	4-6	in-lbs
Adapter Plate Mounting Surface (#2-56 screws)	2-3	in-lbs
Adapter Plate Mounting Surface (#4-40 screws)	4-6	in-lbs
Module Mounting Screw	3.5-4	in-lbs

PHASE RELATIONSHIP

SINGLE-ENDED (S) / DIFFERENTIAL (D) OPTION:

A leads B for clockwise shaft rotation, and B leads A for counterclockwise rotation as viewed from the cover side of the encoder.

BROADCOM/AVAGO COMPATIBLE PIN-OUT (L) OPTION:

B leads A for clockwise shaft rotation, and A leads B for counterclockwise rotation as viewed from the cover side of the encoder.

SINGLE-ENDED ELECTRICAL

- Specifications apply over the entire operating temperature range.
- Typical values are specified at $V_{cc} = 5.0V_{dc}$ and $25^{\circ}C$.
- For complete details, see the EM1 (<https://www.usdigital.com/products/encoders/incremental/modules/em1/>) or EM2 (<https://www.usdigital.com/products/encoders/incremental/modules/em2/>) product pages.

PARAMETER	MIN.	TYP.	MAX.	UNITS	CONDITIONS
Supply Voltage	4.5	5.0	5.5	V	
Supply Current		27	33	mA	CPR < 500, no load
		54	62	mA	CPR ≥ 500 and < 2000, no load
		72	85	mA	CPR ≥ 2000, no load
Low-level Output			0.5	V	I _{OL} = 8mA max., CPR < 2000
			0.5	V	I _{OL} = 5mA max., CPR ≥ 2000
		0.25		V	no load, CPR ≥ 2000
High-level Output	2.0			V	I _{OH} = -8mA max. and CPR < 2000
	2.0			V	I _{OH} = -5mA max. and CPR ≥ 2000
	4.8			V	no load and CPR < 2000
	3.5			V	no load and CPR ≥ 2000
Output Current Per Channel	-8		8	mA	CPR < 2000
	-5		5	mA	CPR ≥ 2000
Output Rise Time		110		nS	CPR < 2000
		50		nS	CPR ≥ 2000, ± 5mA load
Output Fall Time		100		nS	CPR < 2000
		50		nS	CPR ≥ 2000, ± 5mA load

DIFFERENTIAL ELECTRICAL

- Specifications apply over the entire operating temperature range.
- Typical values are specified at V_{CC} = 5.0Vdc and 25°C.
- For complete details, see the EM1 (<https://www.usdigital.com/products/encoders/incremental/modules/em1/>) or EM2 (<https://www.usdigital.com/products/encoders/incremental/modules/em2/>) product pages.

PARAMETER	MIN.	TYP.	MAX.	UNITS	CONDITIONS
Supply Voltage	4.5	5.0	5.5	V	
Supply Current		29	36	mA	CPR < 500, no load
		56	65	mA	CPR ≥ 500 and < 2000, no load
		74	88	mA	CPR ≥ 2000, no load
Low-level Output		0.2	0.4	V	I _{OL} = 20mA max.
High-level Output	2.4	3.4		V	I _{OH} = -20mA max.
Differential Output Rise/Fall Time			15	nS	

PIN-OUTS

5-PIN SINGLE-ENDED (1)		10-PIN DIFFERENTIAL, STANDARD (2)		10-PIN DIFFERENTIAL, L-OPTION (2,3)	
Pin	Description	Pin	Description	Pin	Description
1	Ground	1	Ground	1	No Connection
2	Index	2	Ground	2	+5VDC power
3	A channel	3	Index-	3	Ground
4	+5VDC power	4	Index+	4	No connection
5	B channel	5	A- channel	5	A- channel
		6	A+ channel	6	A+ channel
		7	+5VDC power	7	B- channel
		8	+5VDC power	8	B+ channel
		9	B- channel	9	Index-
		10	B+ channel	10	Index+

(1) 5-pin single-ended mating connector is CON-FC5 (<https://www.usdigital.com/products/accessories/connectors/con-fc5/>).

(2) 10-pin differential mating connector is CON-FC10 (<https://www.usdigital.com/products/accessories/connectors/con-fc10/>).

(3) Broadcom / Avago compatible version.

ACCESSORIES

1. Centering Tool

Part #: CTOOL - (Shaft Diameter)

Description: This reusable tool provides a simple method for accurately centering the **E5** base onto the shaft.

It is recommended for the following situations:

- When using mounting screws smaller than #4-40.
- When the position of the mounting holes is in question.
- When using the 3-hole mounting pattern.
- When using the **T**-option transfer adhesive.

Instructions: When mounting the encoder base, slide the centering tool down the shaft until it slips into the centering hole of the encoder base. Tighten mounting screws, then remove the centering tool.

2. Hex Tool

Depending on the order quantity and packaging option, either a hex driver or hex wrench is included.

Part #: HEXD-050

Description: Hex driver, 0.050" flat-to-flat for #3-48 or #4-48 set screws. Only included with **-B** or **-1** packaging options.

Part #: HEXW-050

Description: Hex wrench, .050" flat-to-flat for #3-48 or #4-48 set screws. Only included with **-2** or **-3** packaging options.

3. Spacer Tool

A spacer tool is included for all packaging options.

Part #: SPACER-E5**4. Screws****Part #: SCREW-080-250-PH**

Description: Pan Head, Phillips #0-80 UNF x 1/4"

Use: Base Mounting

Quantity Required: 3

Screws are not included

Part #: SCREW-256-250-PH

Description: Pan Head, Phillips #2-56 UNC x 1/4"

Use: Base Mounting

Quantity Required: 2

Screws are not included

Part #: SCREW-440-250-PH

Description: Pan Head, Phillips #4-40 UNC x 1/4"

Use: Base Mounting

Quantity Required: 2

Screws are not included

Part #: SCREW-440-500-PH

Description: Pan Head, Phillips #4-40 UNC x 1/2"

Use: Module Mounting

Quantity Required: 2

Screws are included

Part #: SCREW-440-625-FH

Description: Flat Head, Phillips 4-40 UNC x 5/8"

Use: Cover Mounting

Quantity Required: 2

Screws are included

Part #: SCREW-448-063-SS

Description: Socket Head Set Screw, 4-48 UNC x 1/16"

Use: Hub/Disk Mounting for 5/16" - 10mm Bore

Quantity Required: 1

Screw is included

Part #: SCREW-448-125-SS

Description: Socket Head Set Screw, 4-48 UNC x 1/8"

Use: Hub/Disk Mounting for 2mm - 1/4" Bore

Quantity Required: 1

Screw is included

OUTPUT WAVEFORMS

SINGLE-ENDED

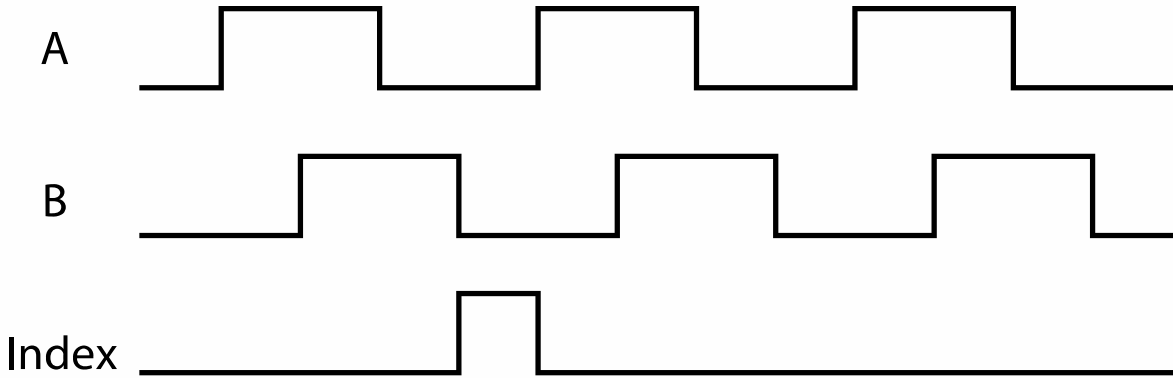

DIFFERENTIAL

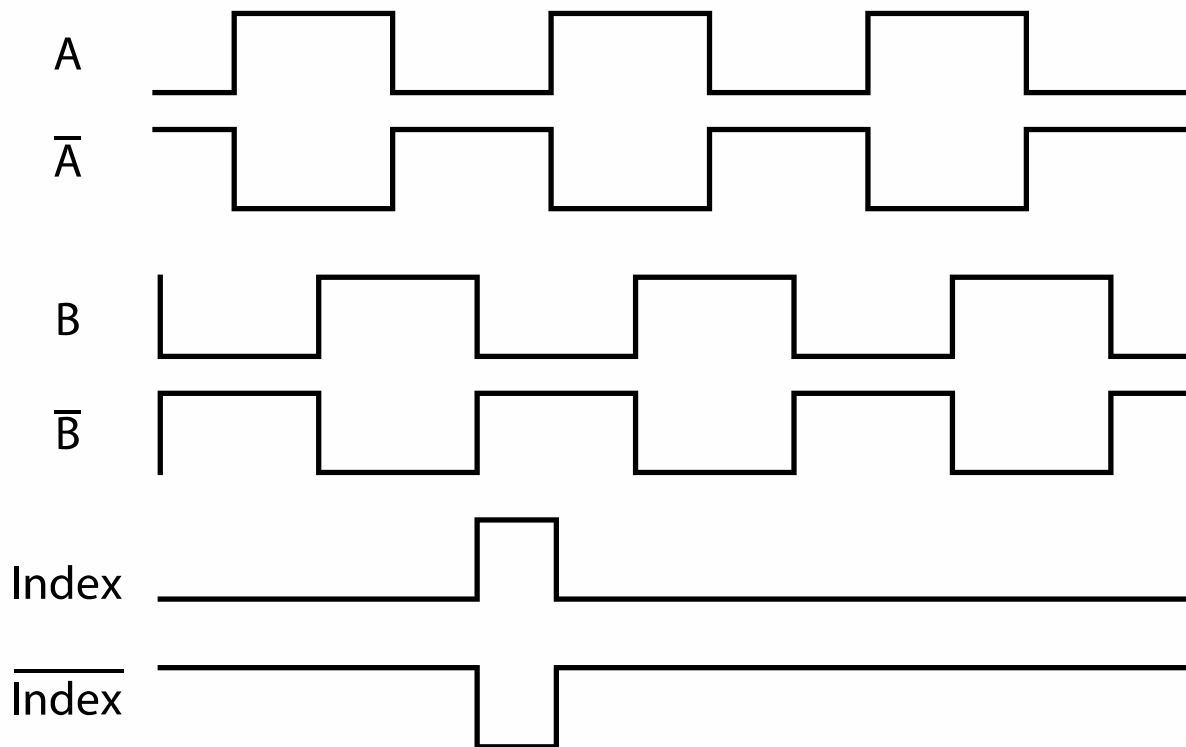

PRODUCT CHANGE NOTIFICATIONS

Title	Date	Description	Download
E2, E5 Packaging - PCN 7190	8/31/2021	As part of our ongoing continuous improvement efforts, US Digital is implementing a change to the individual packaging options of our E2 and E5 kit encoders. It is important to note that this change will not affect the bulk packaging option, also known as our "B" packaging option.	<p>Download</p> <p>https://www.usdigital.com/media/ynclhhlff/e2-e5-packaging-pcn-7190.pdf</p>
Update to 1" and 2" Disks - PCN 6232	5/24/2018	<p>This notice is to inform our customers of a minor disk design modification that is being implemented for standard 1" and 2" disks. This is a continuation of a change that was implemented for our index disks in 2015.</p> <p>We are revising the text on the disk, adding the US Digital logo and a line that is used internally by our manufacturing group.</p> <p>The change does not effect the quadrature or index tracks; therefore, it has no impact on form, fit, or function.</p>	<p>Download</p> <p>https://www.usdigital.com/media/hnsbgrmg/disk-update-pcn-6232.pdf</p>

<p>HUBDISK-1 Packaging Change Notification - PCN 6297</p>	<p>4/30/2018</p>	<p>As part of our ongoing continuous improvement efforts, US Digital is implementing a change to the packaging of our 1-inch Hubdisk assemblies.</p>	<p>Download (https://www.usdigital.com/media/oetpzqhe/pcn-6297-hubdisk-1-packaging.pdf)</p>
		<p>We are replacing the current plastic tube packaging with a 25-count plastic tray. The tray is a two-piece design with a snap-on lid and anti-static coated for ESD-sensitive environments. This change is designed to enhance the ease of handling for our customers, easy removal of the individual hubdisk, and protection against potential damage due to long-term storage of hubdisk assemblies.</p>	
		<p>This change does not affect form, fit, or function of the final product.</p>	
<p>Hub Set Screw Production Change - PCN 5367</p>	<p>7/20/2015</p>	<p>As part of our ongoing continuous improvement efforts, US Digital is implementing a change related to the production of our 5/16" (.313), 8mm (.315), 3/8" (.375), and 10mm (.394) HUBDISK assemblies. We are adding a low-strength threadlocker to the set screw during our assembly process to assist in securing the set screw in the hub during transportation. This will aid in the set screw retention of these specific hub sizes; ensuring the retention is sufficient and avoid the potential of them backing out of the hub assembly during transit.</p>	<p>Download (https://www.usdigital.com/media/ctrc03di/hub-set-screw-pcn-5367.pdf)</p>
		<p>This change does not affect form, fit, or function.</p>	



EM1 & EM2 Update - PCN 4199	1/14/2014	Based on our continuous process improvement program, US Digital is changing the current marking method for our EM1 and EM2 encoder modules to a serialization method. This change will allow for each module to have a unique code; the current marking method is based on a date code system that includes all encoder modules produced within a specific week/year. The serialization system will be based on a hexadecimal system.	Download (https://www.usdigital.com/media/eyffpwwk/pcn-em1-em2-pm-pcn-4199.pdf)
EM1 LED Die - PCN 1016	2/7/2013	As part of US Digital's continual assurance of supply strategy, we have qualified additional sources for our LED die used in our EM1 encoder module, which in turn impacts all of the following products: EM1, E2, E3, E5, E6, H1, H15, H3, H5, H6, HB5M, HB6M, HD25, PE, S1, S2, S5, S6, T5 and T6 The device specification will remain the same, i.e. there will be no change to form, fit, or function of the product(s) as specified by US Digital. The appropriate quality and reliability testing have been performed on representative products to ensure normal parametric distribution, consistent with US Digital's quality and reliability standards.	Download (https://www.usdigital.com/media/hygpmtx3/em1-led-die-pcn-1016.pdf)

E5 Insert Overmold - PCN 1008	8/23/2011	In an effort to enhance the robustness of our E5 encoder; the four threaded inserts pressed into the base are being replaced with similarly threaded nuts that will be insert-molded into the encoder base. This change in process will retain the insert with much greater strength.	Download (https://www.usdigital.com/support/resources/product-change-notifications/pcn-1008-e5-insert-overmold/)
E5 Laser Marking - PCN 1009	8/23/2011	The primary purpose of this change is to create a more durable and longer-lasting solution compared to the previous stick-on-label solution. The E5 encoder covers will now have the US Digital logo, part number, lot code, and pin-outs laser marked onto the top surface.	Download (https://www.usdigital.com/support/resources/product-change-notifications/pcn-1009-e5-laser-marking/)
E5 Mold Update - PCN 1007	8/23/2011	The plastic E5 base and covers have been redesigned for improved moldability and aesthetics. Design changes are primarily alteration of surface drafts, additional or increased corner radii, and additional coring out of thick regions. This update was carefully done to preserve the size and shape of the encoder. The new parts are dimensionally equivalent and will fit within the envelope of the previous parts. Only the E-option covers and the G-option bases have features with dimensional changes.	Download (https://www.usdigital.com/media/zrkecu3p/e5-mold-update-pcn-1007.pdf)

Notes

- Cables and connectors are not included and must be ordered separately.
- US Digital® warrants its products against defects in materials and workmanship for two years. See complete warranty (<https://www.usdigital.com/company/warranty>) for details.