



Figure 1. Physical Photo of AHV30V18KVR5MAW

FEATURES

Regulated and stable output voltage: $<\pm 1\%$ @ $-20 \sim 65^\circ\text{C}$

High efficiency: 60% @ $18\text{kV}0.5\text{mA}$

Proportional monitoring voltage: $V_{\text{MON}} = V_{\text{OUT}} \div 1000$

Reverse input voltage protection up to 40V

Fully shield

APPLICATIONS

This power module, AHV30V18KVR5MAW, is designed for achieving DC-DC conversion from low voltage to high voltage. High voltage power supply is widely used in industry, agriculture, national defense, scientific research and other fields including: X-ray machine high voltage power supply, laser high voltage power supply, spectral analysis high voltage power supply, nondestructive inspection high voltage power supply, semiconductor manufacturing equipment high voltage power supply, capillary electrophoresis high voltage power supply, nondestructive detection high voltage power supply, particles injection high

voltage power supply in semiconductor technology, physical vapor phase deposition high voltage power supply, nanolithography high voltage power supply. They are widely applied in ion beam deposition, ion beam assisted deposition, electron beam evaporation, electron beam welding, ion source, DC reactive magnetron sputtering, glass / fabric coating, glow discharge, microwave treatment high voltage capacitance test, CRT monitor test, high voltage cable fault test (PD testing), TWT test, and H-POT test. Particle accelerator, free electron laser, neutron source, cyclotron accelerator, capacitor and inductance pulse generator, Marx high voltage pulse generator, and capacitor charger. Microwave heating, radio frequency amplification, nanotechnology application, electrostatic technology application, electrospinning preparation of nanofiber, high voltage power supply for nuclear power and other products.

DESCRIPTION

AHV30V18KVR5MAW converts an input DC voltage of 27V to 30V, to an output voltage of 18kV with high



efficiency. It allows monitoring the output voltage by measuring the voltage of an output voltage monitor port: multiplying the value 1000 times equals the output voltage. The monitoring output voltage uses shielding wires. The core is the positive and the shield is the negative. The whole converter is shielded by a heavy duty metal enclosure, which blocks incoming and outgoing EMIs. This feature is particularly important for noise intensive environment.

Draw a clear distinction between input lead and output lead: input 27V ~ 30V (red lead), output ground (blue lead), and

output high-tension cable (thick brown lead).

SAFETY PRECAUTIONS

The internal protection circuit is provided in the high voltage power supply, but the high voltage short circuit shall be avoided.

Make sure the circuit is insulated perfectly, especially between the high voltage output and the surroundings so as to avoid electronic shock.

SPECIFICATIONS

Table 1. Characteristics

T_A = 25°C, unless otherwise noted

Parameter	Symbol	Condition	Min.	Typ.	Max.	Unit/Note
Input Voltage Operating Range	V _{IN}		27	30	32	V
Maximum Input Voltage	V _{INMAX}			44		V
Maximum Reverse Input Voltage	V _{INRVMAX}			-44		V
Quiescent Input Current	I _{INQQ}	I _{OUT} = 0mA	75	80	85	mA
Full Load Input Current	I _{INFLD}	I _{OUT} = 0.5mA	400	450	500	mA
Start-up Overshoot at Output	V _{OVST}	I _{OUT} = 0 ~ 0.5mA			25	V
Input Ripple Current	I _{INRP}	I _{OUT} = 0 ~ 0.5mA			50	mA
Input Voltage Regulation Ratio	ΔV _{OUT} /ΔV _{IN}	V _{IN} = 27V ~ 32V		≤0.05		%
Output Voltage	V _{OUT}	I _{OUT} = 0 ~ 0.5mA	17820	18000	18180	V
Maximum Output Current	I _{OUTMAX}	V _{IN} = 27V to 32V			0.5	mA
Maximum allowable Over-ride Voltage at the Output Voltage					23	KV
Operating Temperature Rang	T _{opr}		-20		65	°C
Monitor Voltage Out Impedance	Z _{VMON}			1		MΩ
Monitor Voltage Attenuation Ratio	V _{OUT} /V _{MON}	V _{OUT} = 0 ~ 18kV	998	1000	1020	
Monitor Voltage	V _{MON}	V _{OUT} = 0 ~ 18kV	0		18	V
Instantaneous Short Circuit Current	I _{SC}			<500		mA
Output Voltage noise				≤0.5		%
Full Load Efficiency	η			≥60		%
Temperature Coefficient	TCV _O	-20 ~ 65°C		<0.01		%/°C
Output Voltage Temperature Stability		-20 ~ 65°C		<±1		%
Load regulation rate		I _{OUT} = 0 ~ 0.5mA		≤0.05		%
Storage Temperature Range	T _{stg}		-55		100	°C



Weight				310		g
				0.68		lbs
				10.9		Oz

THE CONNECTION DIAGRAM OF MODULE'S PERIPHERAL CIRCUIT

The leads colors in the figure below are identical with those in the physical AHV30V18KVR5MAW.

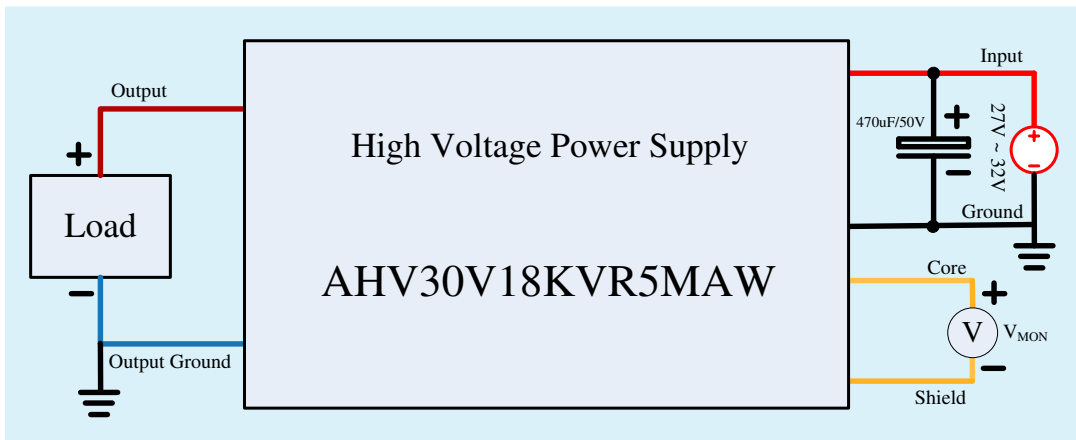

Figure 2. External Connection

DIMENSIONS

I. Dimension of the leads.

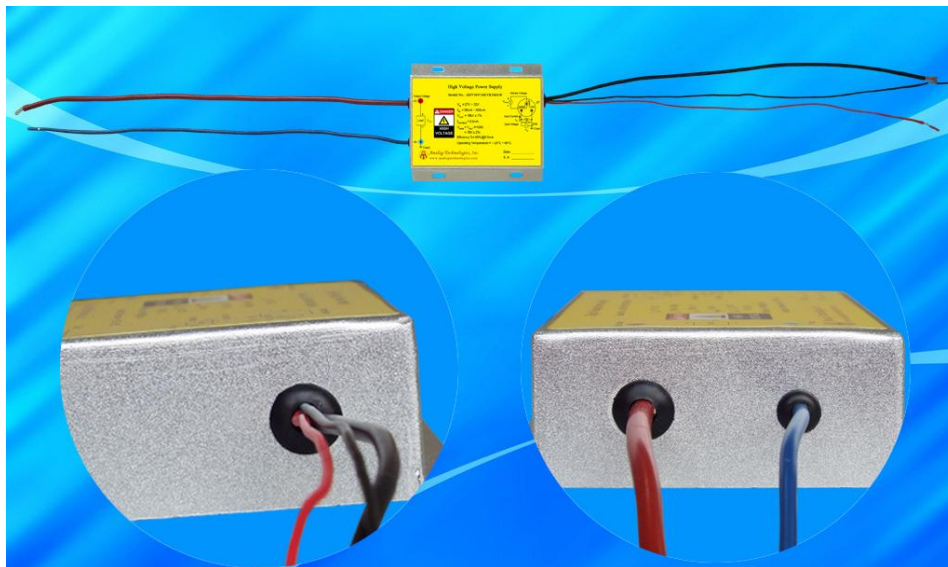

Figure 3. Leads of AHV30V18KVR5MAW



Leads	Diameter (mm)	Length (mm)
Thick brown lead	4.5	30
Blue	3.0	30
Red and black	1.5	30
Shield	3.0	30

NAMING INSTRUCTIONS

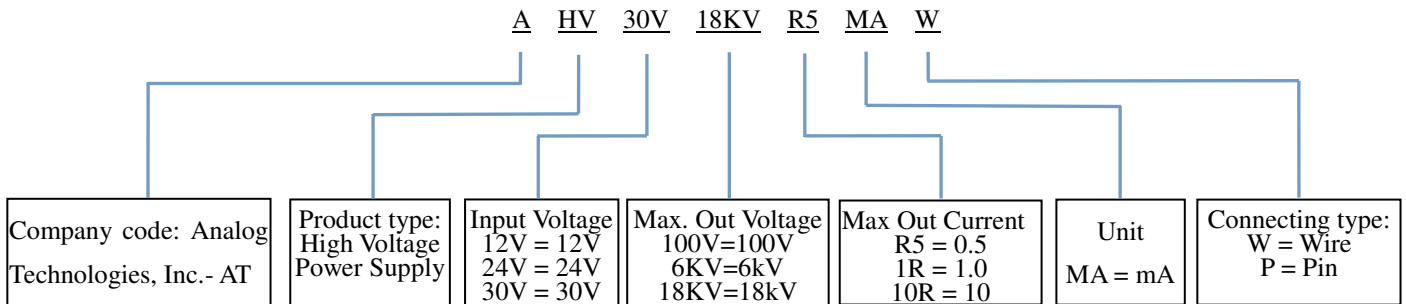

Figure 4. Naming Rules of AHV30V18KVR5MAW

II. Dimension of AHV30V18KVR5MAW.

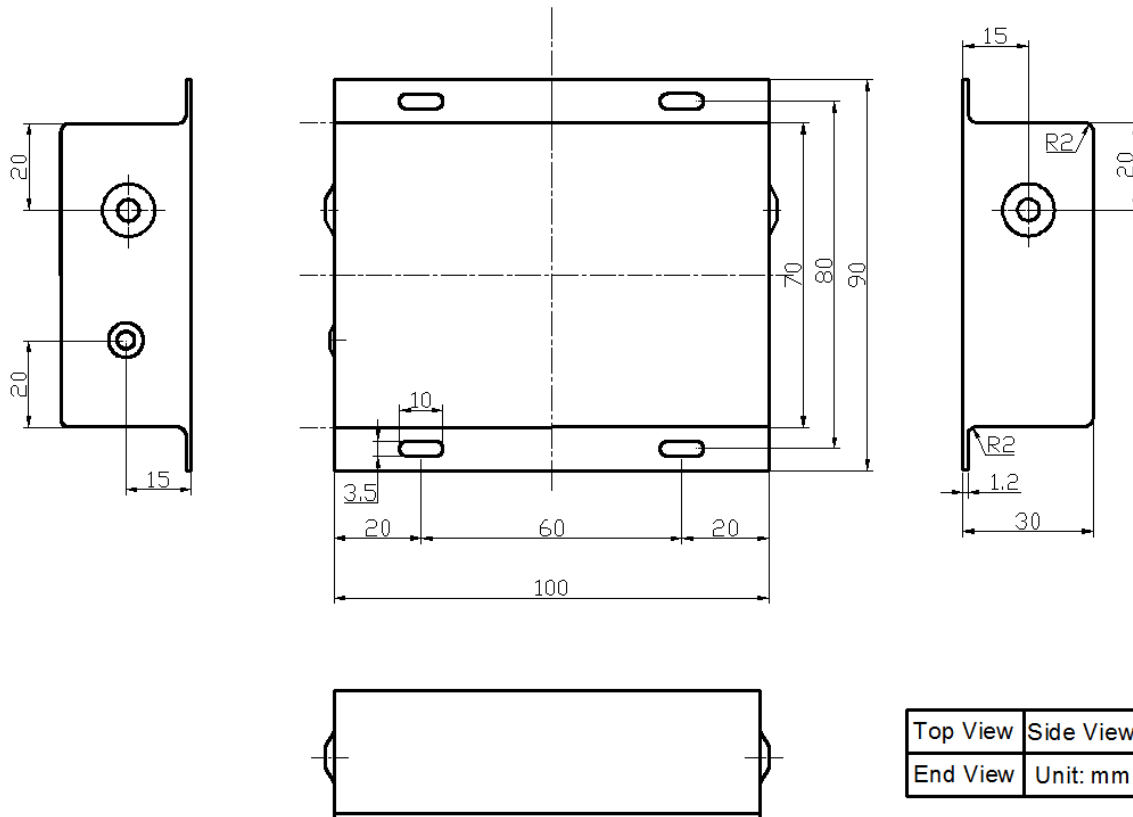

Figure 5. Dimensions for AHV30V18KVR5MAW



PRICES

Quantity	1~9pcs	10~49pcs	50~99pcs	≥100
AHV30V18KVR5MAW	\$398	\$388	\$378	\$368

NOTICE

- ATI warrants performance of its products for one year to the specifications applicable at the time of sale, except for those being damaged by excessive abuse. Products found not meeting the specifications within one year from the date of sale can be exchanged free of charge.
- ATI reserves the right to make changes to its products or to discontinue any product or service without notice, and advise customers to obtain the latest version of relevant information to verify, before placing orders, that information being relied on is current and complete.
- All products are sold subject to the terms and conditions of sale supplied at the time of order acknowledgment, including those pertaining to warranty, patent infringement, and limitation of liability. Testing and other quality control techniques are utilized to the extent ATI deems necessary to support this warranty. Specific testing of all parameters of each device is not necessarily performed, except those mandated by government requirements.
- Customers are responsible for their applications using ATI components. In order to minimize risks associated with the customers' applications, adequate design and operating safeguards must be provided by the customers to minimize inherent or procedural hazards. ATI assumes no liability for applications assistance or customer product design.
- ATI does not warrant or represent that any license, either express or implied, is granted under any patent right, copyright, mask work right, or other intellectual property right of ATI covering or relating to any combination, machine, or process in which such products or services might be or are used. ATI's publication of information regarding any third party's products or services does not constitute ATI's approval, warranty or endorsement thereof.
- IP (Intellectual Property) Ownership: ATI retains the ownership of full rights for special technologies and/or techniques embedded in its products, the designs for mechanics, optics, plus all modifications, improvements, and inventions made by ATI for its products and/or projects.