

Multi-Channel PWM Power Drivers for LED Applications

Check for Samples: [DRV9812](#) [DRV9822](#)

FEATURES

- **Four Independent Synchronized Buck, Boost, or Two Buck-Boost PWM Controlled Power Stages**
- **High-Efficiency Power Stage (up to 96%) with Low $R_{DS(on)}$ MOSFETs (80 m Ω at $T_J = 25^\circ\text{C}$)**
- **Operating Supply Voltage up to 50 V**
- **DRV9812 (Pad down): up to 2.5A Continuous Output Current**
- **DRV9822 (pad up): up to 5A Continuous Output Current**
- **PWM Operating Frequency up to 1 MHz**
- **Integrated Self-Protection Circuits**
- **Programmable Cycle-by-Cycle Current Limit Protection**
- **Two-Stage Thermal Protection**
- **Independent Supply Pin for Each Channel**
- **Intelligent Gate Drive and Cross Conduction Prevention**

APPLICATIONS

- **Multi-Channel Buck, Boost, or Buck-Boost Power Stages**
- **LED Drivers**

DESCRIPTION

The DRV9812/22 are wide input voltage (up to 50V) synchronous multi-channel PWM power stages for LED applications. They can be configured as buck, boost, or buck-boost topology depending on application requirements and can drive 4 independent LED strings with up to 15 power LEDs in series per string. They can also provide DC, sine wave, or any other kind of desired current to drive LEDs based on PWM control algorithm from external MCU controller.

Because of the integrated low $R_{DS(on)}$ MOSFETs and intelligent gate drive design, the efficiency of the DRV9812/22 can be as high as 96%. They have all the protections integrated on-chip, safeguarding the device against a wide range of fault conditions such as short-circuit protection, overcurrent protection, undervoltage protection, and two-stage thermal protection. A programmable overcurrent detector allows adjustable cycle-by-cycle current limit to meet different power requirements.

The DRV9812/22 have unique independent supply pin for each channel, which make them possible to support multiple outputs with different power supply voltage requirements or mixed converter topologies.

Simplified Application Diagram

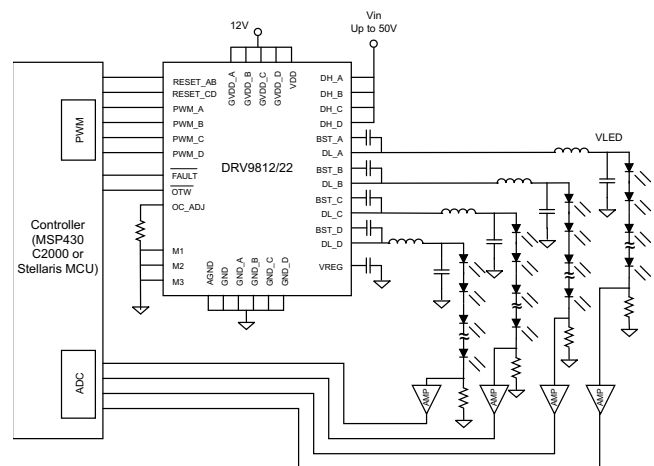
PRODUCT PREVIEW

Please be aware that an important notice concerning availability, standard warranty, and use in critical applications of Texas Instruments semiconductor products and disclaimers thereto appears at the end of this data sheet.