



**ANATECH ELECTRONICS INC**  
RF & Microwave Filters & Products

# DC-825 MHz / 865-2700 MHz Cavity Notch Filter

**Part Number: AE845N2245**



## Electrical Specifications

**Notch Center Frequency:** 845 MHz  
**Notch Frequency range:** 835-855 MHz  
**Notch Rejection:**  $\geq 40$ dB  
**Passband low side of Notch:** DC-825 MHz  
**Passband High side of Notch:** 865-2700 MHz  
**Insertion loss in Passband:**  $\leq 0.75$  dB  
**Return Loss in Passband:**  $\geq 14$  dB  
**Input/output Impedance:** 50 Ohms  
**Power Handling:**  $\leq 25$  Watts

## Mechanical

**Mounting Method:** Threaded Holes  
**Connector Type:** SMA(F)  
**Dimensions:** 258 X 85 X 59.5 mm.  
**Dimensions:** 10.15 X 3.35 X 2.34 in.

## Environmental

**Operating Temperature:**  $-20^{\circ}\text{C}$  to  $+70^{\circ}\text{C}$   
**Storage Temperature:**  $-40^{\circ}\text{C}$  to  $+85^{\circ}\text{C}$   
**Shock:** 20 G. 11ms  
**Vibration:** 20 G. 5 to 200Hz

## Outline Drawing:

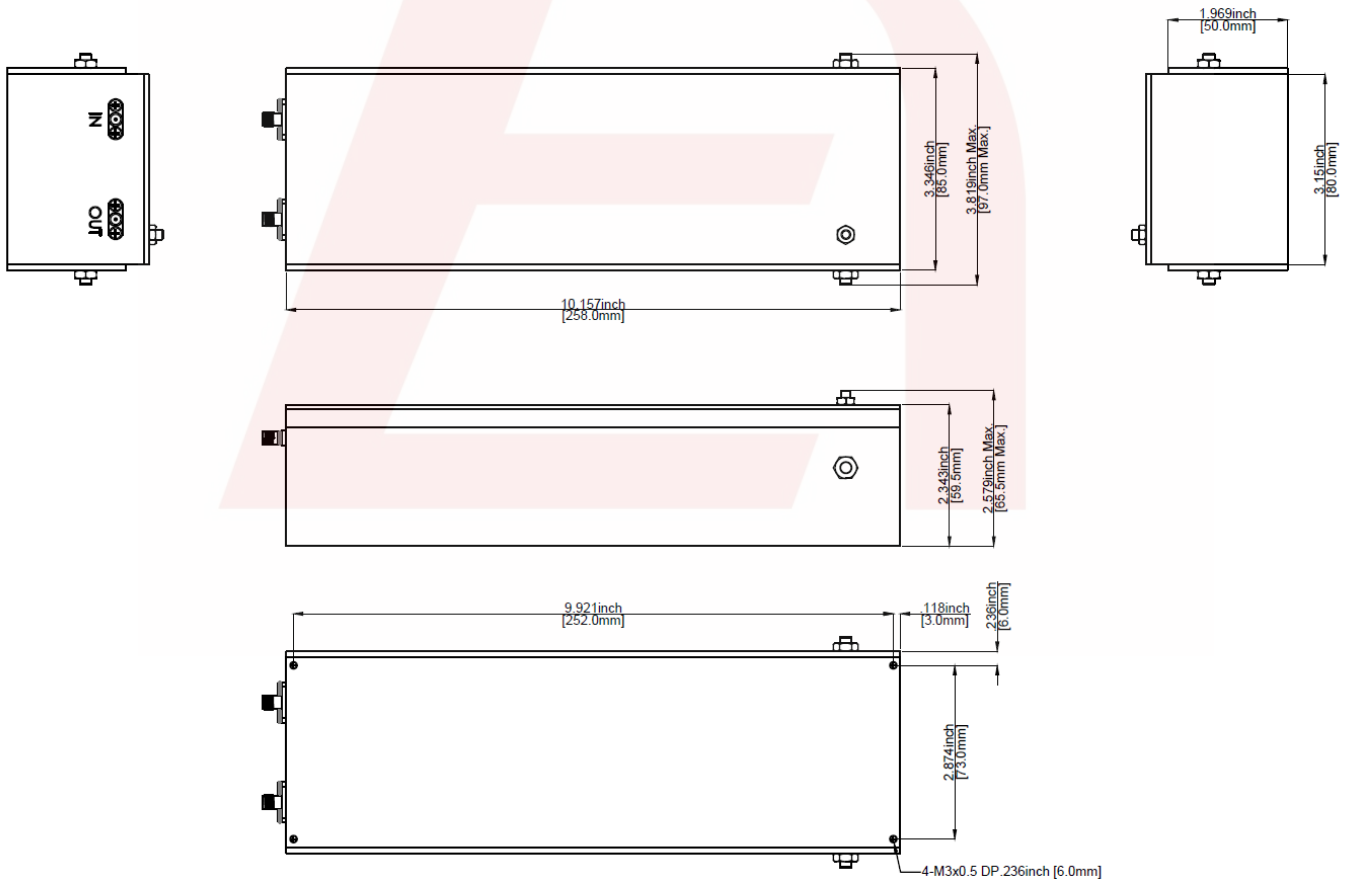

Tolerance:  $\pm 0.01$  inches [ $\pm 0.3$ mm]

Angles:  $\pm 1$  Deg.

\*Tolerance as shown unless otherwise specified in the datasheet electrical specification tables above.

\*When max dimensions are called out the above tolerances do not apply as long as it is under the max call out.

DS-N2245-02112020-Rev0

**70 Outwater Lane Phone: (973) 772-4242**  
**Garfield, NJ 07026 Fax : (973) 321-3941**

**Email: [sales@anatechelectronics.com](mailto:sales@anatechelectronics.com)**  
**Web: [www.anatechelectronics.com](http://www.anatechelectronics.com)**



**Simulation Plot:**

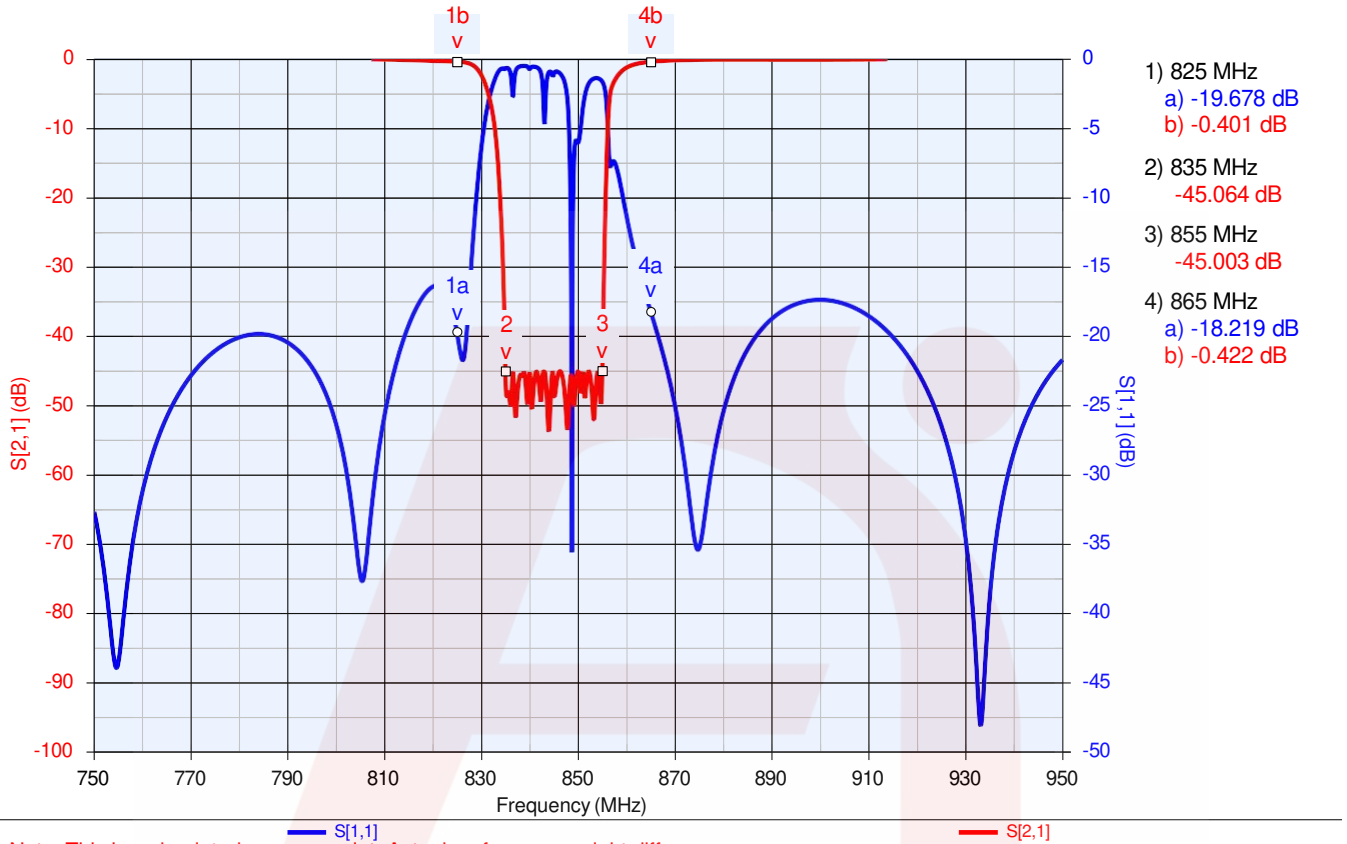

Note: This is a simulated response plot. Actual performance might differ.