

Industrial 3D-Scan Line module

VLM-650-30 Series



FEATURES:

- Industrial 3D-Scan Red Line Laser.
- High contrast Gaussian line profile.
- Line thickness <math><1.2\text{mm}</math> (60° type) at Working Range 50mm ~ 400mm.
- High Laser line accuracy : 4/1000(<math><1.6\text{mm}</math> @400mm).
- This module has integrated quartz cylindrical lens, collimating lens, laser diode, and APC driver circuit.
- Advanced APC circuit to provide maximum stable laser power output.
- Dimensions : $\text{Ø } 10 \times 27.1 \text{ mm}$ ($\text{Ø } 0.394" \times 1.067"$).
- Wavelength : 650 nm
- Laser power output : less than 1mW.
- Fan Angle : 60° or 90°
- 5 VDC operation.
- Connection type: Lead wire
- Built-in Laser Emissions indicator (LED)

APPLICATIONS:

- Specifically optimized for Industrial 3D scanner.
- High accuracy Red Straight Line Laser, Line-width optimize at short distance (50~400mm), for Industrial high-precision barcode reader, leveling, alignment, adjusting, measuring and targeting device
- Wood processing.
- Metal processing.
- Stone processing.
- Textile industry.
- Food industry.
- Automotive industry.
- Medical science.

VLM-650-30 Series

OUTLINE DIMENSIONS (UNITS: mm)

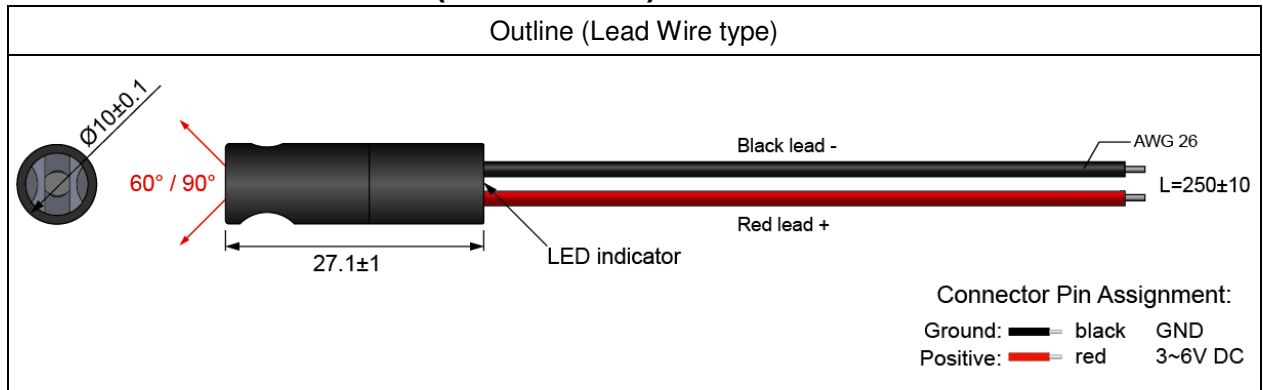

SPECIFICATIONS

SPECIFICATIONS		VLM-650-30 LPT10(60°)	VLM-650-30 LPT10(90°)	VLM-650-30 LPT30(60°)	VLM-650-30 LPT30(90°)
1	Fan Angle	60°	90°	60°	90°
2	Dimensions	Ø10 x 27.1 mm (Ø0.413" x 1.066")			
3	Operating Voltage	3~6V			
4	Operating Current	Less than 40 mA		Less than 60 mA	
5	Optical power*	Less than 5mW		Less than 20mW	
6	Laser power output**	Less than 0.39mW		Less than 1mW	
7	Laser class	Class 1M		Class 2M	
8	Wavelength	635~665nm			
9	Mode of operation	Auto Power Control (APC)			
10	Exit Aperture Protection	Glass Window with AR Coating			
11	Emissions Indicator	Red LED Indicator			
12	Lens Material	Aspherical Plastic + Glass (Rod lens)			
13	Laser line accuracy	4/1000(Less than 1.6mm @400mm)			
14	Beam alignment	Less than 3°			
15	Line thickness (13.5%)	Less than 1.2mm	Less than 1.5mm	Less than 1.2mm	Less than 1.5mm
16	Output power Stability(25°C)	Total Fluctuation <5%			
17	Modulation	Continuous wave (CW), Switching up to 1KHz			
18	Line Intensity profile	Gaussian Line			
19	Working Range	50mm~400mm			
20	Operating temp. range***	+15°C ~+40°C			

VLM-650-30 Series

21	Storage temp. range	-20°C ~+65°C
22	Housing Material	Aluminum with Black Anodized
23	Potential of housing	Insulated
24	Electrostatic discharge (ESD)	30KV
25	Moisture sensitivity level (MSL)	Level 1 - acc to JEDEC J-STD-020E.
26	Wire type	1007-26AWG
27	Cable length	250±10mm
28	Application	Precision 3D scanner
29	Suggestion work distance	20~60 cm / 8"~24"

* Optical power is total power output measured at the aperture of the laser.

** According to FDA 1040.10 & IEC 60825-1 regulations, laser power output is measured by 7mm aperture stop from a 10 cm distance of the laser.

*** Operation temperature means within this temperature range, the laser spot/line will not be affected to change the spot size/line width. It can still work over this range, but the laser spot size or laser line width will be larger.

ORDER CODE

Order Code	Wavelength	Optical power*	Laser power output**	Laser Class	Connection Type
VLM-650-30 LPT10(60°)	650 nm	Less than 5mW	Less than 0.39mW	Class 1M	Lead Wire
VLM-650-30 LPT10(90°)	650 nm	Less than 5mW	Less than 0.39mW	Class 1M	Lead Wire
VLM-650-30 LPT30(60°)	650 nm	Less than 20mW	Less than 1mW	Class 2M	Lead Wire
VLM-650-30 LPT30(90°)	650 nm	Less than 20mW	Less than 1mW	Class 2M	Lead Wire

* Optical power is total power output measured at the aperture of the laser.

** According to FDA 1040.10 & IEC 60825-1 regulations, laser power output is measured by 7mm aperture stop from a 10 cm distance of the laser.

SAFETY LABEL

CLASS I LASER PRODUCT

