

LEDiL

PRODUCT RELEASE

## REBECCA – Let your true colours shine

Meet LEDiL's new REBECCA, an innovative hybrid optical solution designed to provide perfect colour mixing with a range of high power multi-chip LEDs. REBECCA is an excellent choice for high quality stage, retail and architectural lighting applications for both RGBW and tuneable CCT light sources.

REBECCA's combination of a mixing chamber and TIR optics with LEDiL's proprietary RZ-surfaces provides a smooth beam with excellent colour uniformity.

### TYPICAL APPLICATIONS

- Architectural lighting
- Stage lighting
- Retail lighting



CA13949\_REBECCA-RGB

## TECHNICAL SPECIFICATIONS

- Diameter 42 mm
- Height 29.9 mm
- Typical FWHM  $\approx 20^\circ$
- Optimized for colour mixing, consists of mixing chamber and TIR lens with RZ-surface
- Qualified for Cree XM-L RGBW and Osram Ostar Stage LEDs and Luxeon Z 4-up clusters

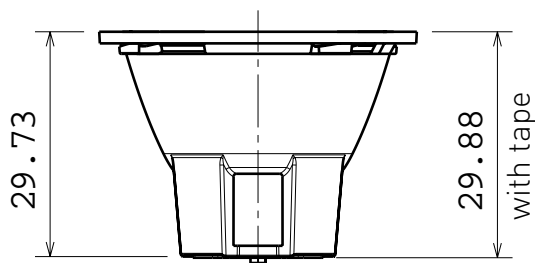

Front view

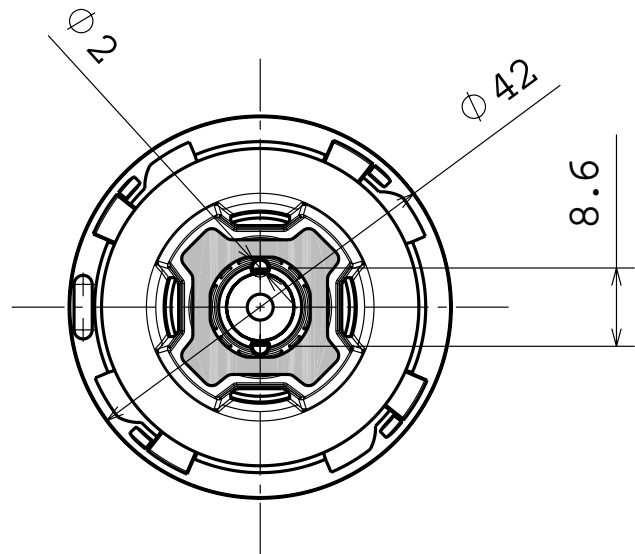

Bottom view



### REBECCA-RGB beam with Cree XM-L RGB LED

A smooth beam with excellent colour uniformity achieved with REBECCA's combination of mixing chamber and TIR optics with LEDiL's proprietary RZ-surfaces.

## ORDERING INFORMATION

CA13949\_REBECCA-RGB

Consult [www.ledil.com](http://www.ledil.com) for ordering codes and latest product specifications, which may vary by LED