

Copying of this document and giving it to others and the use or communication of the contents thereof, are forbidden without express authority. Offenders are liable to the payment of damages. All rights are reserved in the event of the grant of a patent or the registration of the utility model or design.

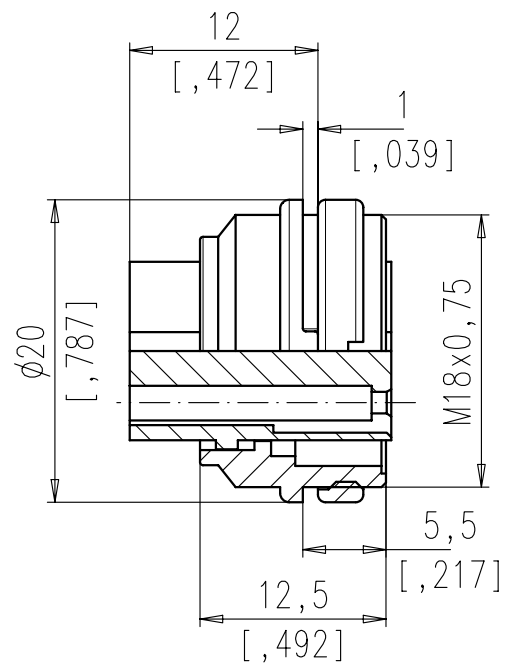

Montageausschnitt  
Panel Cutout

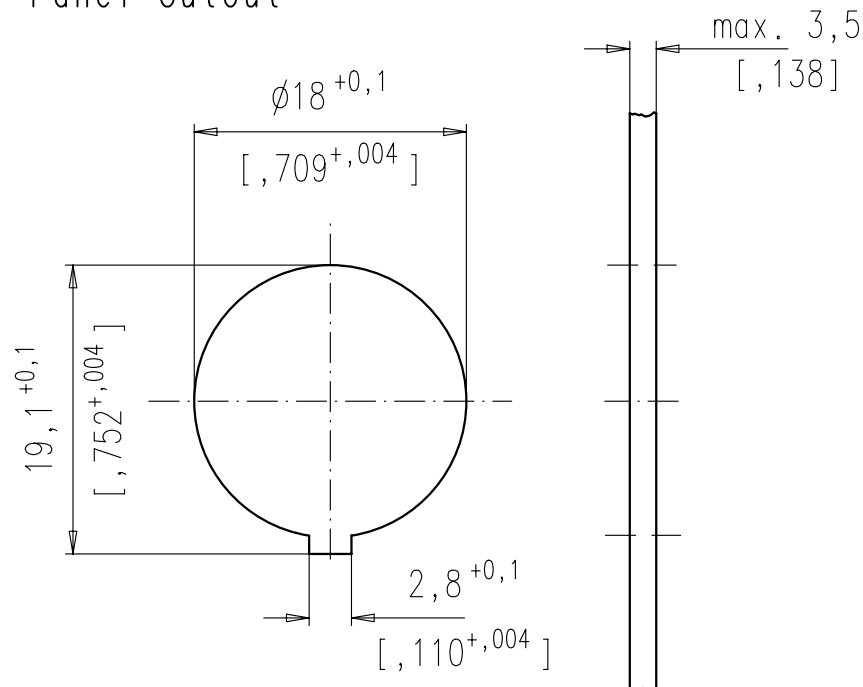

	14	T 3653 150 U
	12	T 3638 150 U
	8 IEC	T 3507 150 U
	7 IEC	T 3487 150 U
	7	T 3478 150 U
	6	T 3403 150 U
	5	T 3363 150 U
	5 IEC	T 3359 150 U
	4	T 3303 150 U
	3	T 3263 150 U
SYMBOL symbol	POLZAHL number of contacts	TYP-NUMBER-CRIMP type-number-crimp

Polzahl number of contacts	Norm standard	3	4	5	5	6	7	7	8	12	14	
Kontaktanordnung nach DIN contact arrangement acc. to DIN		41524 60130-9	- 60130-9	-	41524 60130-9	45322 60130-9	-	45329 60130-9	45326 60130-9	-	-	
Kontaktanordnung nach IEC contact arrangement acc. to IEC												
Bemessungsspannung rated voltage	IEC 60664-1	300V =		100V =		300V =		100V =		150V =		
Bemessungsspannung rated voltage	UL 1977	250V										
Bemessungs-Stoßspannung rated impulse withstand voltage	IEC 60664-1	1500V		1200V		1500V		1200V				
Verschmutzungsgrad pollution degree	IEC 60664-1	1										
Überspannungskategorie installation category	IEC 60664-1	I										
Isolierstoffgruppe insulation group	IEC 60664-1	II, 400 ≤ CTI < 600										
Strombelastbarkeit current rating	IEC 60512-5-2 Test 5b UL 1977	5A / +40°C / +104°F						3A / +40°C / +104°F				
Isolationswiderstand insulation resistance	IEC 60512-3-1 Test 3a	>10 <sup>10</sup> Ω										
Durchgangswiderstand contact resistance	IEC 60512-2-1 Test 2a	< 5m Ω										
Prüfklasse climatic category	IEC 60068-1	40 / 100 / 56										
Temperaturbereich temperatur range	IEC 60068-1	-40°C ... +100°C -40°F ... +212°F										
IP-Schutzart IP-degree	IEC 60529	IP 40										
Steck- und Ziehkraft Insertion and withdrawal forces	IEC 60512-13-2 Test 13b	25N 90.oz	30N 110.oz	35N 125.oz	50N 180.oz	55N 200.oz	60N 220.oz	50N 180.oz				
Mechanische Lebensdauer mechanical operation	IEC 60512-9-1 Test 9a	silber/silver ≥ 500 Steckzyklen/mating cycles gold/gold ≥ 1000 Steckzyklen/mating cycles										
Werkstoff Gehäuse housing material		Überwurfmutter Messing, Zugentlastung Zink-Druckguß, Oberfläche vernickelt coupling ring brass, strain relief, die cast, nickel plated										
Werkstoff Kontaktträger dielectric material		Thermoplast thermoplastic										
Kontaktoberfläche contact plating		versilbert/vergoldet silver plated/gold plated										
Anschlussstechnik termination technique		crimpen crimp										
Anschlussquerschnitt wire gauge		crimp: 2-6 pol(ausschließlich/excluding 5S): 0,09-1,00mm <sup>2</sup> / 28-18 AWG crimp 5S, 7, 7S, 8 pol: 0,09-0,75mm <sup>2</sup> / 28-20 AWG										
Brennbarkeit flammability		UL 94 V0										
Verriegelung locking system	IEC 60130-9	schrauben: Anziehdrehmoment 0,7Nm metal screw coupling: tightening torque 0,7Nm										

Diese Steckverbinder dürfen betriebsmäßig nicht unter Spannung betätigt werden. Metallene Gehäuseteile sind sicher mit dem Schutzleitersystem zu verbinden.  
Do not connect or disconnect under load. Metal housing parts shall be securely incorporated to protected ground.

Crimpkontakte bitte separat bestellen, Details siehe M-N 02 015 00XX (X) oder Katalog C091 A/B/D Seite 44  
please order crimp contacts separately, details see M-N 02 015 00XX (X) or catalog C091 A/B/D page 44

Gewicht (errechnet)/ Calc WT:	9	Zul. Abw./Tolerances:		Maßstab/Scale	2:1	A3	
Prüfmaß/Test dimension		DIN/ISO	13715	CUSTOMER DRAWING			
Teileindex Part index number		04	Datum/Date	Name	Gerätedose Female receptacle		
		Gez. Drawn	29.09.	Meuser			
		Gep. Checked					
02	200700144	25.06.08	CI	Amphenol-Tuchel Electronics GmbH			
01	200400530	29.09.04	Me	M GA T 3XXX 150			
Index	Änderung/Description	Datum/Date	Name	Ers. f./Similar to:			
				Blatt/Sheet 1 1 Bl.			

Weitergabe sowie Vervielfältigung dieser Unterlage, Verwertung und Mitteilung ihres Inhalts nicht gestattet, soweit nicht ausdrücklich zugestanden. Zuwiderhandlungen verpflichten zu Schadenersatz. Alle Rechte für den Fall der Patenterteilung oder Gebrauchsmuster-Eintragung vorbehalten.