



# MIC841/842

## Comparator with 1.25% Reference and Adjustable Hysteresis

### General Description

The MIC841 and MIC842 are micropower, precision voltage comparators with an on-chip voltage reference.

Both devices are intended for voltage monitoring applications. External resistors are used to set the voltage monitor threshold. When the threshold is crossed, the outputs switch polarity.

The MIC842 incorporates a voltage reference and comparator with fixed internal hysteresis; two external resistors are used to set the switching threshold voltage. The MIC841 provides a similar function with user adjustable hysteresis; this part requires three external resistors to set the upper and lower thresholds (the difference between the threshold voltages being the hysteresis voltage).

Both the MIC841 and MIC842 are available with push-pull or open-drain output stage. The push-pull output stage is configured either active high or active low; the open-drain output stage is only configured active low.

Supply current is extremely low (1.5µA, typical), making it ideal for portable applications.

The MIC841/2 is supplied in Micrel's Teeny™ 5-pin SC-70, 6-pin 1.6mm × 1.6mm Thin DFN (MIC841), and 4-pin 1.2mm × 1.6mm Thin DFN (MIC842) packages.

Datasheets and support documentation are available on Micrel's web site at: [www.micrel.com](http://www.micrel.com).

### Features

- 1.5V to 5.5V operating range
- 1.5µA typical supply current
- ±1.25% voltage threshold accuracy
- 10nA maximum input leakage current overtemperature
- 10µs propagation delay
- Externally adjustable hysteresis (MIC841)
- Internal 20mV hysteresis (MIC842)
- Output options
  - Push-pull, active high
  - Push-pull, active low
  - Open drain, active low
- Open drain output can be pulled to 6V regardless of V<sub>DD</sub>
- Immune to brief input transients
- Teeny 5-pin SC-70 package
- 6-pin 1.6mm × 1.6mm TDFN (MIC841)
- 4-pin 1.2mm × 1.6mm TDFN (MIC842)

### Applications

- Smart phones
- PDAs
- Precision battery monitoring
- Battery chargers

### Typical Application

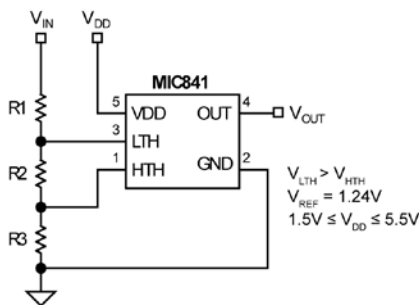

Threshold Detection with Adjustable Hysteresis

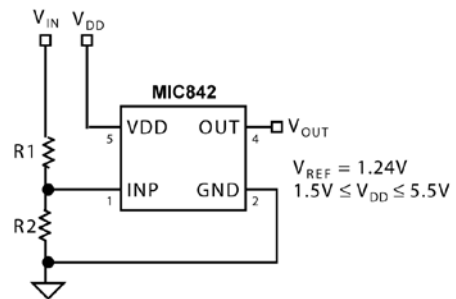

Threshold Detector with Internal Fixed Hysteresis

Teeny is a trademark of Micrel, Inc.

Micrel Inc. • 2180 Fortune Drive • San Jose, CA 95131 • USA • tel +1 (408) 944-0800 • fax + 1 (408) 474-1000 • <http://www.micrel.com>

## Ordering Information

Part Number	Marking	Hysteresis Adjustment	Output Stage	Output Function	Temperature Range	Pb-Free	Package
MIC841HBC5	B13	External	Push Pull	Active Low	-40°C to +85°C		SC-70-5
MIC841LBC5	B14	External	Push Pull	Active High	-40°C to +85°C		SC-70-5
MIC841NBC5	B15	External	Open Drain	Active Low	-40°C to +85°C		SC-70-5
MIC842HBC5	B16	Internal	Push Pull	Active Low	-40°C to +85°C		SC-70-5
MIC842LBC5	B17	Internal	Push Pull	Active High	-40°C to +85°C		SC-70-5
MIC842NBC5	B18	Internal	Open Drain	Active Low	-40°C to +85°C		SC-70-5
MIC841HYC5	<u>B</u> 13	External	Push Pull	Active Low	-40°C to +85°C	✓	SC-70-5
MIC841HYMT	BH	External	Push Pull	Active Low	-40°C to +85°C	✓	1.6mm × 1.6mm TDFN
MIC841LYC5	<u>B</u> 14	External	Push Pull	Active High	-40°C to +85°C	✓	SC-70-5
MIC841LYMT	BL	External	Push Pull	Active High	-40°C to +85°C	✓	1.6mm × 1.6mm TDFN
MIC841NYC5	<u>B</u> 15	External	Open Drain	Active Low	-40°C to +85°C	✓	SC-70-5
MIC841NYMT	BN	External	Open Drain	Active Low	-40°C to +85°C	✓	1.6mm × 1.6mm TDFN
MIC842HYC5	<u>B</u> 16	Internal	Push Pull	Active Low	-40°C to +85°C	✓	SC-70-5
MIC842HYMT	HB	Internal	Push Pull	Active Low	-40°C to +85°C	✓	1.2mm × 1.6mm TDFN
MIC842LYC5	<u>B</u> 17	Internal	Push Pull	Active High	-40°C to +85°C	✓	SC-70-5
MIC842LYMT	HL	Internal	Push Pull	Active High	-40°C to +85°C	✓	1.2mm × 1.6mm TDFN
MIC842NYC5	<u>B</u> 18	Internal	Open Drain	Active Low	-40°C to +85°C	✓	SC-70-5
MIC842NYMT	HN	Internal	Open Drain	Active Low	-40°C to +85°C	✓	1.2mm × 1.6mm TDFN

## Pin Configurations

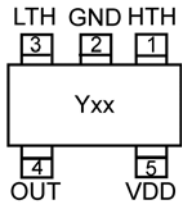

**MIC841**  
SC-70-5 (CS)  
(Top View)

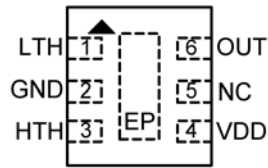

**MIC841**  
6-Pin 1.6mm x 1.6mm TDFN (MT)  
(Top View)

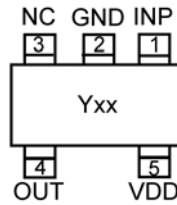

**MIC842**  
SC-70-5 (CS)  
(Top View)

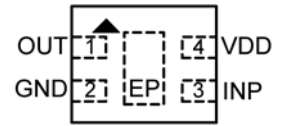

**MIC842**  
4-Pin 1.2mm x 1.6mm TDFN (MT)  
(Top View)

## MIC841 Pin Description

Pin Number SC-70	Pin Number TDFN	Pin Name	Pin Function
1	3	HTH	High Threshold Input. HTH and LTH monitor external voltages.
2	2	GND	Ground.
3	1	LTH	Low Threshold Input. LTH and HTH monitor external voltages.
4	6	OUT	("H" Version) Active-Low Push-Pull Output. OUT asserts low when $V_{LTH} < V_{REF}$ . OUT remains low until $V_{HTH} > V_{REF}$ .
		OUT	("L" Version) Active-High Push-Pull Output. OUT asserts high when $V_{LTH} < V_{REF}$ . OUT remains high until $V_{HTH} > V_{REF}$ .
		OUT	("N" Version) Active-Low, Open-Drain Output. OUT asserts low when $V_{LTH} < V_{REF}$ . OUT remains low until $V_{HTH} > V_{REF}$ .
5	4	VDD	Power Supply Input
–	5	NC	No Connect. Not internally connected
–	EP	ePad	Heatsink Pad. Connect to GND for best thermal performance.

## MIC842 Pin Description

Pin Number SC-70	Pin Number TDFN	Pin Name	Pin Function
1	3	INP	Threshold Input. INP monitors an external voltage.
2	2	GND	Ground
3	–	NC	No Connect. Not internally connected.
4	1	OUT	("H" Version) Active-Low, Push-Pull Output. OUT asserts low when $V_{INP} < V_{REF}$ . OUT remains low until $V_{INP} > (V_{REF} + V_{HYST})$ .
		OUT	("L" Version) Active-High, Push-Pull Output. OUT asserts high when $V_{INP} < V_{REF}$ . OUT remains high until $V_{INP} > (V_{REF} + V_{HYST})$ .
		OUT	("N" Version) Active-Low, Open-Drain Output. OUT asserts low when $V_{INP} < V_{REF}$ . OUT remains low until $V_{INP} > (V_{REF} + V_{HYST})$ .
5	4	VDD	Power Supply Input
–	EP	ePad	Heatsink Pad. Connect to GND for best thermal performance.

**Absolute Maximum Ratings<sup>(1)</sup>**

Supply Voltage ( $V_{DD}$ )	–0.3V to +7V
Input Voltage ( $V_{INP}$ , $V_{LTH}$ , $V_{LTL}$ )	+7V
Output Current ( $I_{OUT}$ )	±20mA
Storage Temperature ( $T_S$ )	–65°C to +150°C
Junction Temperature ( $T_J$ )	+150°C
ESD Rating <sup>(3)</sup>	1kV

**Operating Ratings<sup>(2)</sup>**

Supply Voltage ( $V_{DD}$ )	+1.5V to +5.5V
Input Voltage ( $V_{INP}$ , $V_{LTH}$ , $V_{LTL}$ )	0V to 6V
$V_{OUT}$ ('H' and 'L' versions)	$V_{DD}$
$V_{OUT}$ ('N' version)	6V
Ambient Temperature Range ( $T_A$ )	–40°C to +85°C
Package Thermal Resistance	
SC-70-5 ( $\theta_{JA}$ )	256.5°C/W
6-pin 1.6mm × 1.6mm TDFN	92°C/W
4-pin 1.2mm × 1.6mm TDFN	173°C/W

**Electrical Characteristics<sup>(4)</sup>**

1.5V ≤  $V_{DD}$  ≤ 5.5V;  $T_A$  = +25°C, **bold** values indicate –40°C ≤  $T_A$  ≤ +85°C, unless noted.

Symbol	Parameter	Condition	Min.	Typ.	Max.	Units
$I_{DD}$	Supply Current	Output not asserted		1.5	<b>3</b>	μA
$I_{INP}$	Input Leakage Current			0.005	<b>10</b>	nA
$V_{REF}$	Reference Voltage	0°C to 85°C	<b>1.225</b>	1.240	<b>1.256</b>	V
		–40°C to 85°C	<b>1.219</b>	1.240	<b>1.261</b>	
$V_{HYST}$	Hysteresis Voltage <sup>(5)</sup>	MIC842 only	<b>8</b>	20	<b>35</b>	mV
$t_D$	Propagation Delay	$V_{INP} = 1.352V$ to 1.128V		12	<b>50</b>	μs
		$V_{INP} = 1.143V$ to 1.367V		8	<b>50</b>	
$V_{OUT}^{(6)}$	Output Voltage-Low	$I_{SINK} = 1.6mA$ , $V_{DD} \geq 1.6V$		0.05	<b>0.3</b>	V
		$I_{SINK} = 100\mu A$ , $V_{DD} \geq 1.2V$		0.005	<b>0.4</b>	
	Output Voltage-High	$I_{SOURCE} = 500\mu A$ , $V_{DD} \geq 1.6V$			0.99 $V_{DD}$	V
		$I_{SOURCE} = 50\mu A$ , $V_{DD} \geq 1.2V$			0.99 $V_{DD}$	

**Notes:**

- Exceeding the absolute maximum rating may damage the device.
- The device is not guaranteed to function outside its operating rating.
- Devices are ESD sensitive. Handling precautions recommended. Human body model, 1.5kΩ in series with 100pF.
- Specification for packaged product only.
- $V_{HTH} = V_{REF} + V_{HYST}$ .
- $V_{DD}$  operating range is 1.5V to 5.5V. Output is guaranteed to be de-asserted down to  $V_{DD} = 1.2V$ .

## Block Diagrams<sup>(7)</sup>

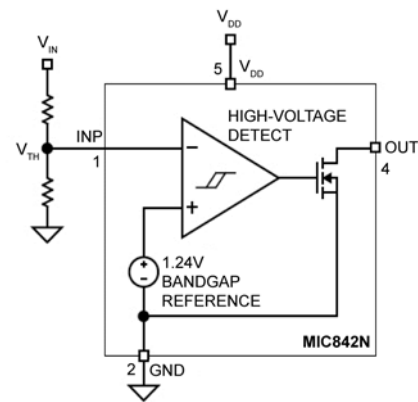
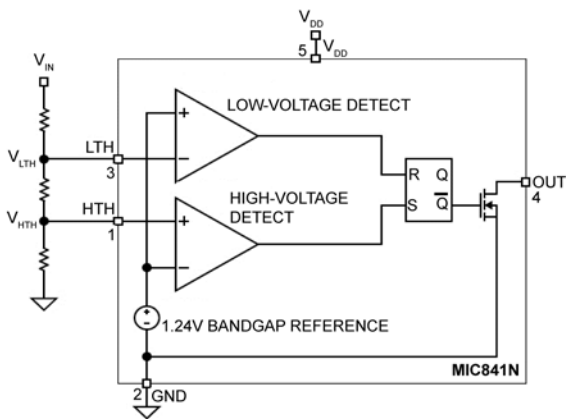
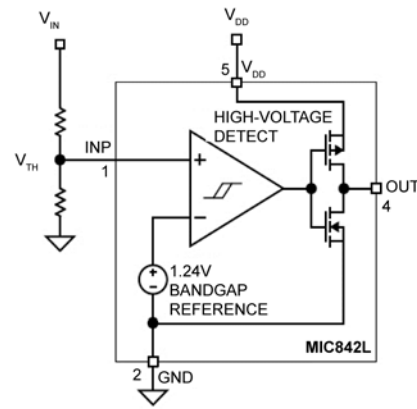
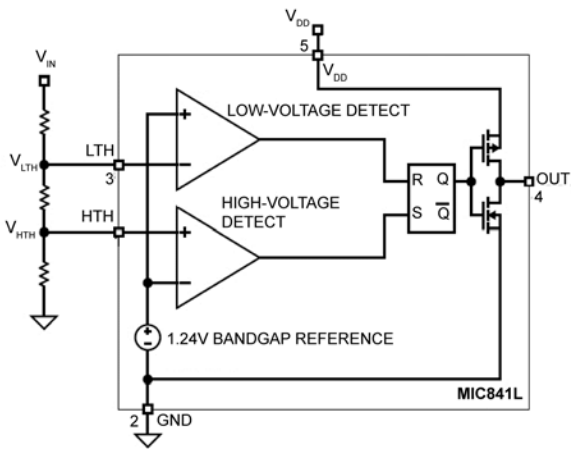
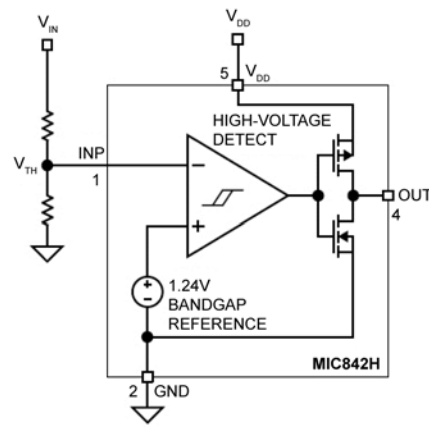
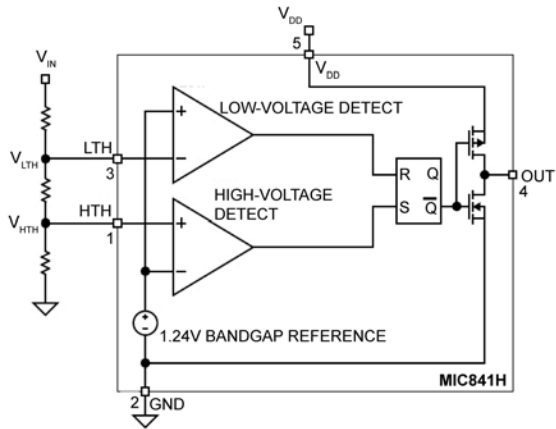

**Note:**

7. SC-70 package pin numbers shown.

## Application Information

### Output

The MIC841N and MIC842N outputs are an open-drain MOSFET, so most applications will require a pull-up resistor. The value of the resistor should not be too large or leakage effects may dominate. 470kΩ is the maximum recommended value. Note that the output of “N” version may be pulled up as high as 6V regardless of the ICs supply voltage. The “H” and “L” versions of the MIC841 and MIC842 have a push-pull output stage, with a diode clamped to VDD. Thus, the maximum output voltage of the “H” and “L” versions is V<sub>DD</sub> (see [Electrical Characteristics](#)).

When working with large resistors on the input to the devices, a small amount of leakage current can cause voltage offsets that degrade system accuracy. The maximum recommended total resistance from V<sub>IN</sub> to ground is 3MΩ. The accuracy of the resistors can be chosen based upon the accuracy required by the system. The inputs may be subjected to voltages as high as 6V steady-state without adverse effects of any kind regardless of the ICs supply voltage. This applies even if the supply voltage is zero. This permits the situation in which the IC’s supply is turned off, but voltage is still present on the inputs (see [Electrical Characteristics](#)).

### Programming the MIC841 Thresholds

The low-voltage threshold is calculated using Equation 1:

$$V_{IN(LO)} = V_{REF} \left( \frac{R1 + R2 + R3}{R2 + R3} \right) \quad \text{Eq. 1}$$

The high-voltage threshold is calculated using Equation 2:

$$V_{IN(HI)} = V_{REF} \left( \frac{R1 + R2 + R3}{R3} \right) \quad \text{Eq. 2}$$

Where, for both equations:

$$V_{REF} = 1.240V$$

In order to provide the additional criteria needed to solve for the resistor values, the resistors can be selected such that they have a given total value, that is, R<sub>1</sub> + R<sub>2</sub> + R<sub>3</sub> = R<sub>TOTAL</sub>. A value such as 1MΩ for R<sub>TOTAL</sub> is a reasonable value because it draws minimum current but has no significant effect on accuracy.

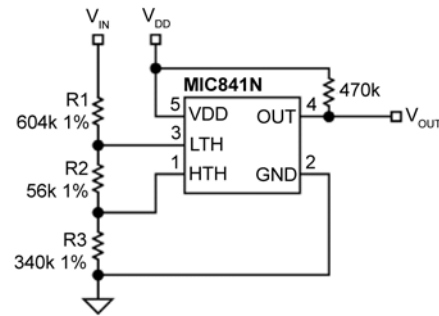

Figure 1. MIC841 Example Circuit

Once the desired trip points are determined, set the V<sub>IN(HI)</sub> threshold first.

For example, use a total of 1MΩ = R<sub>1</sub> + R<sub>2</sub> + R<sub>3</sub>. For a typical single-cell lithium ion battery, 3.6V is a good “high threshold” because at 3.6V the battery is moderately charged. Solving for R<sub>3</sub>:

$$V_{IN(HI)} = 3.6V = 1.24V \left( \frac{1M\Omega}{R3} \right) \quad \text{Eq. 3}$$

Where:

$$R3 = 344k\Omega$$

Once R<sub>3</sub> is determined, the equation for V<sub>IN(LO)</sub> can be used to determine R<sub>2</sub>. A single lithium-ion cell, for example, should not be discharged below 2.5V. Many applications limit the drain to 3.1V.

Using 3.1V for the  $V_{IN(LO)}$  threshold allows calculation of the two remaining resistor values:

$$V_{IN(LO)} = 3.1V = 1.24V \left( \frac{1M\Omega}{R2 + 344k\Omega} \right) \quad \text{Eq. 4}$$

Where:

$$R2 = 56k\Omega$$

$$R1 = 1M\Omega - R2 - R3$$

$$R1 = 600k\Omega$$

The accuracy of the resistors can be chosen based upon the accuracy required by the system.

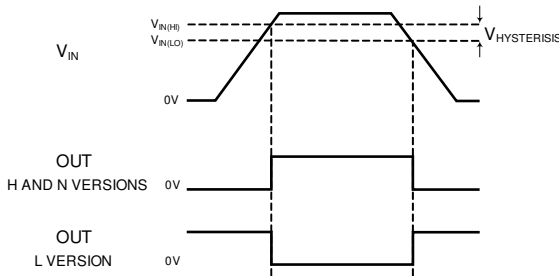

Figure 2. Output Response and Hysteresis

### Programming the MIC842 Thresholds

The voltage threshold is calculated using Equation 5:

$$V_{IN(LO)} = V_{REF} \left( \frac{R1 + R2}{R2} \right) \quad \text{Eq. 5}$$

Where:

$$V_{REF} = 1.240V$$

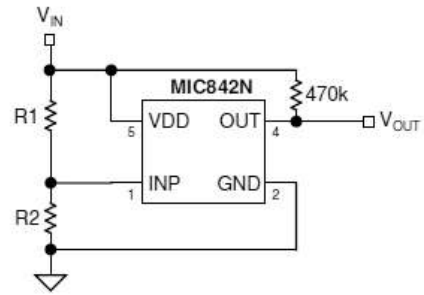

Figure 3. MIC842 Example Circuit

In order to provide the additional criteria needed to solve for the resistor values, the resistors can be selected such that they have a given total value, that is,  $R1 + R2 = R_{TOTAL}$ . A value such as  $1M\Omega$  for  $R_{TOTAL}$  is a reasonable value because it draws minimum current but has no significant effect on accuracy.

### Input Transients

The MIC841/2 is inherently immune to very short negative-going “glitches.” Very brief transients may exceed the  $V_{IN(LO)}$  threshold without tripping the output.

As shown in Figure 4, the narrower the transient, the deeper the threshold overdrive that will be ignored by the MIC841/2. The graph represents the typical allowable transient duration for a given amount of threshold overdrive that will not generate an output.

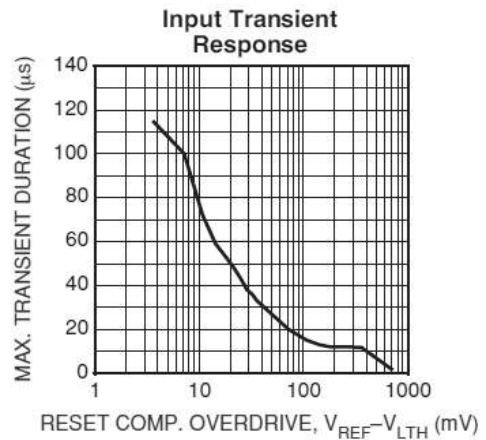
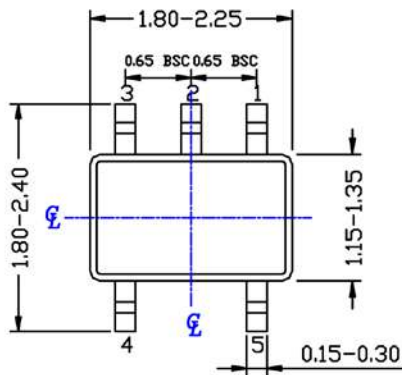
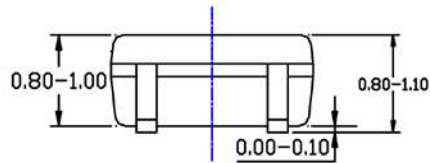

Figure 4. Input Transient Response

**Package Information<sup>(8)</sup> and Recommended Landing Patterns**



TOP VIEW



SIDE VIEW

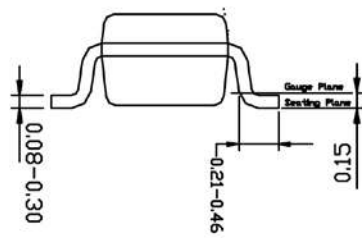

END VIEW

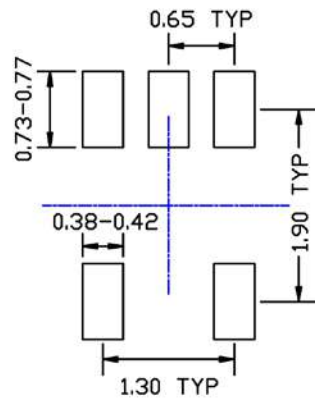

RECOMMENDED LAND PATTERN

**NOTE:**

1. ALL DIMENSIONS ARE IN MILLIMETERS.
2. DIMENSIONS ARE INCLUSIVE OF PLATING.
3. DIMENSIONS ARE EXCLUSIVE OF MOLD FLASH & METAL BURR.

**5-Pin SC-70 (C5)**

**Note:**

8. Package information is correct as of the publication date. For updates and most current information, go to [www.micrel.com](http://www.micrel.com).



**Package Information<sup>(8)</sup> and Recommended Landing Patterns (Continued)**

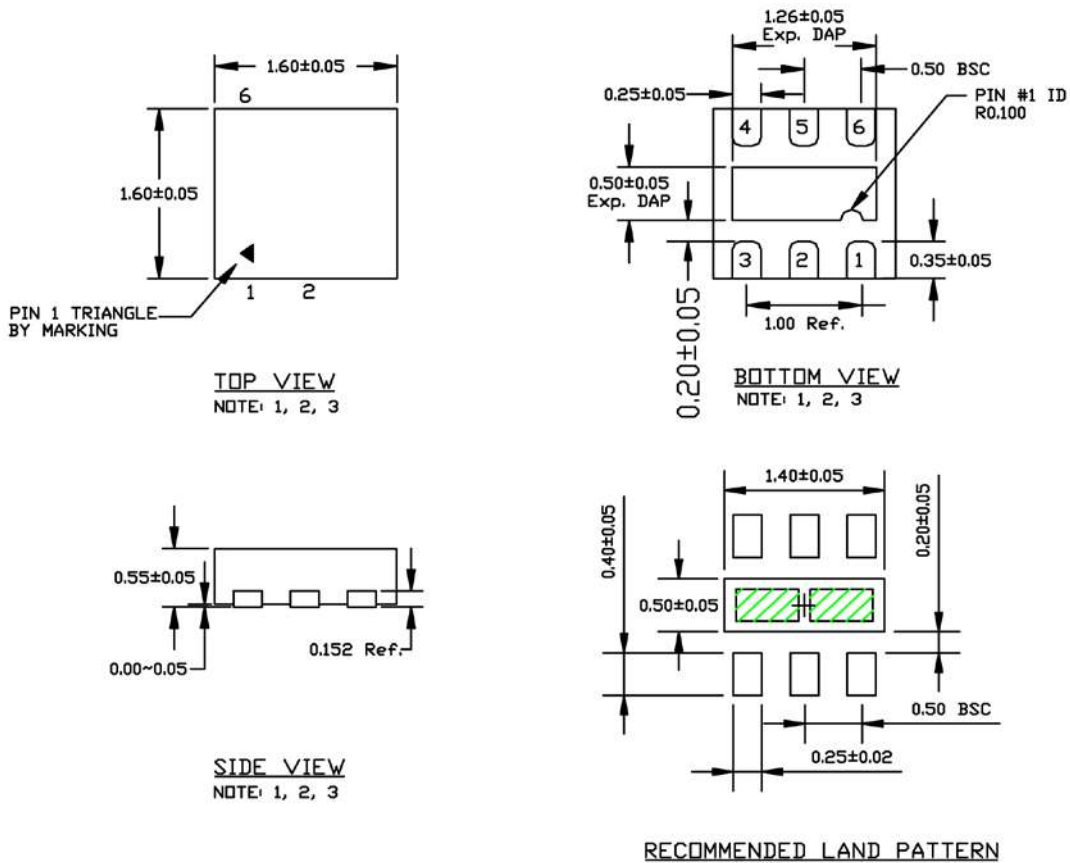

- NOTE:
1. MAX PACKAGE WARPAGE IS 0.05 MM
  2. MAX ALLOWABLE BURR IS 0.076MM IN ALL DIRECTIONS
  3. PIN #1 IS ON TOP WILL BE LASER MARKED
  4. GREEN SHADED AREA REPRESENT SOLDER STENCIL OPENING (OPTIONAL) FOR IMPROVED THERMAL PERFORMANCE. SIZE: 0.55x0.30MM

**6-Pin 1.6mm x 1.6mm TDFN (MT)**

**Package Information<sup>(8)</sup> and Recommended Landing Patterns (Continued)**

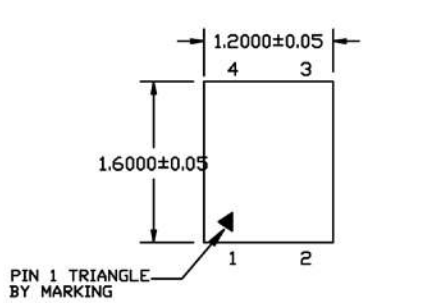

**TOP VIEW**

NOTE: 1, 2, 3

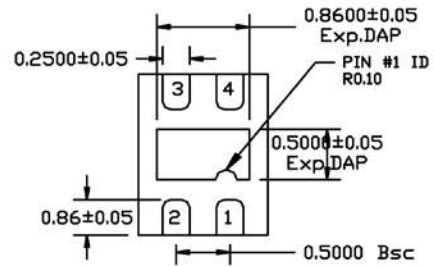

**BOTTOM VIEW**

NOTE: 1, 2, 3

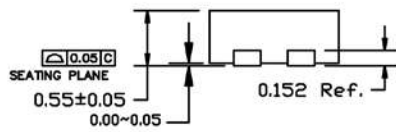

**SIDE VIEW**

NOTE: 1, 2, 3

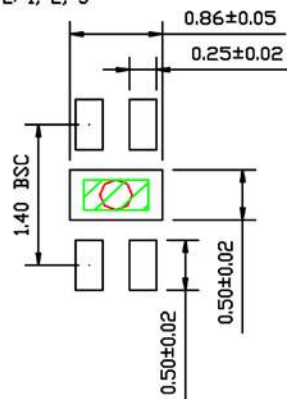

**RECOMMENDED LAND PATTERN**

NOTE: 4, 5

- NOTE:
1. MAX PACKAGE WARPAGE IS 0.05 MM
  2. MAX ALLOWABLE BURR IS 0.076MM IN ALL DIRECTIONS
  3. PIN #1 IS ON TOP WILL BE LASER MARKED
  4. SHADED AREA INDICATE SOLDER STENCIL OPENING (OPTIONAL) FOR IMPROVED THERMAL PERFORMANCE. 0.60 x 0.30MM RECOMMENDED SIZE.
  5. RED CIRCLE REPRESENTS THERMAL VIA & SHOULD BE CONNECTED TO GND FOR MAX PERFORMANCE. 0.30 - 0.35MM RECOMMENDED DIAMETER.

**4-Pin 1.2mm x 1.6mm TDFN (MT)**

---

**MICREL, INC. 2180 FORTUNE DRIVE SAN JOSE, CA 95131 USA**  
TEL +1 (408) 944-0800 FAX +1 (408) 474-1000 WEB <http://www.micrel.com>

Micrel makes no representations or warranties with respect to the accuracy or completeness of the information furnished in this data sheet. This information is not intended as a warranty and Micrel does not assume responsibility for its use. Micrel reserves the right to change circuitry, specifications and descriptions at any time without notice. No license, whether express, implied, arising by estoppel or otherwise, to any intellectual property rights is granted by this document. Except as provided in Micrel's terms and conditions of sale for such products, Micrel assumes no liability whatsoever, and Micrel disclaims any express or implied warranty relating to the sale and/or use of Micrel products including liability or warranties relating to fitness for a particular purpose, merchantability, or infringement of any patent, copyright or other intellectual property right.

Micrel Products are not designed or authorized for use as components in life support appliances, devices or systems where malfunction of a product can reasonably be expected to result in personal injury. Life support devices or systems are devices or systems that (a) are intended for surgical implant into the body or (b) support or sustain life, and whose failure to perform can be reasonably expected to result in a significant injury to the user. A Purchaser's use or sale of Micrel Products for use in life support appliances, devices or systems is a Purchaser's own risk and Purchaser agrees to fully indemnify Micrel for any damages resulting from such use or sale.

© 2012 Micrel, Incorporated.