

Coaxial

# Power Splitter/Combiner

2 Way-0° 50Ω 5 to 500 MHz

ZFSC-2-1+



Generic photo used for illustration purposes only  
CASE STYLE: K18

Connectors	Model
BNC	ZFSC-2-1+
SMA	ZFSC-2-1-S+
N-TYPE	ZFSC-2-1-N+
<b>BRACKET (OPTION "B")</b>	

**+RoHS Compliant**

The +Suffix identifies RoHS Compliance. See our web site for RoHS Compliance methodologies and qualifications

## Maximum Ratings

Operating Temperature	-55°C to 100°C
Storage Temperature	-55°C to 100°C
Power Input (as a splitter)	1W max.
Internal Dissipation	0.125W max.

Permanent damage may occur if any of these limits are exceeded.

## Coaxial Connections

SUM PORT	3
PORT 1	1
PORT 2	2

## Features

- wideband, 5 to 500 MHz
- low insertion loss, 0.3 dB typ.
- excellent isolation, 28 dB typ.
- excellent amplitude unbalance, 0.1 dB typ.
- good VSWR, 1.2:1 typ.
- rugged shielded case

## Applications

- VHF/UHF
- instrumentation
- communication systems

## Outline Drawing

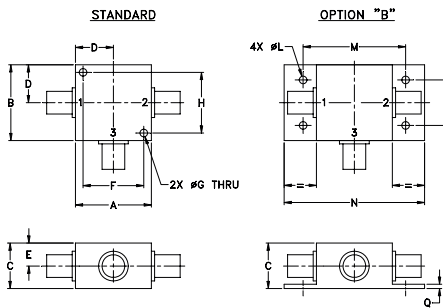

## Outline Dimensions (inch/mm)

A	B	C	D	E	F	G	H
1.25	1.25	.75	.63	.38	1.00	.125	1.000
31.75	31.75	19.05	16.00	9.65	25.40	3.18	25.40
J	K	L	M	N	P	Q	wt
--	--	.125	1.688	2.18	.75	.07	grams
--	--	3.18	42.88	55.37	19.05	1.78	70.0

For option B with N-type connectors, dimension "C" increases to 0.94 inches.

## Electrical Specifications

FREQ. RANGE (MHz)	ISOLATION (dB)						INSERTION LOSS (dB) ABOVE 3.0 dB						PHASE UNBALANCE (Degrees)			AMPLITUDE UNBALANCE (dB)		
	L		M		U		L		M		U		L	M	U	L	M	U
	Typ.	Min	Typ.	Min	Typ.	Min	Typ.	Max.	Typ.	Max.	Typ.	Max.	Max.	Max.	Max.	Max.	Max.	Max.
$f_L$ - $f_U$	30	25	28	20	25	20	0.2	0.5	0.3	0.6	0.6	0.8	2	4	4	0.15	0.15	0.30

L = low range [ $f_L$  to  $10 f_L$ ] M = mid range [ $10 f_L$  to  $f_U/2$ ] U = upper range [ $f_U/2$  to  $f_U$ ]

## Typical Performance Data

Frequency (MHz)	Total Loss <sup>1</sup> (dB)		Amplitude Unbalance (dB)	Isolation (dB)	Phase Unbalance (deg.)	VSWR S	VSWR 1	VSWR 2
	S-1	S-2						
20	3.17	3.17	0.00	38.54	0.08	1.02	1.05	1.05
35	3.18	3.19	0.00	37.55	0.05	1.03	1.04	1.05
80	3.23	3.23	0.00	35.20	0.01	1.05	1.05	1.05
140	3.27	3.28	0.01	32.86	0.01	1.07	1.06	1.06
170	3.29	3.30	0.01	31.68	0.03	1.09	1.06	1.06
200	3.31	3.32	0.01	30.89	0.05	1.10	1.07	1.07
225	3.33	3.34	0.02	30.37	0.09	1.11	1.07	1.07
250	3.33	3.35	0.02	29.60	0.08	1.12	1.08	1.08
290	3.35	3.38	0.03	28.75	0.13	1.14	1.09	1.09
330	3.38	3.41	0.03	28.01	0.17	1.15	1.09	1.10
370	3.39	3.43	0.04	27.35	0.21	1.17	1.10	1.11
410	3.41	3.46	0.05	26.80	0.25	1.19	1.11	1.12
450	3.43	3.48	0.05	26.31	0.30	1.21	1.12	1.13
475	3.44	3.50	0.06	26.09	0.32	1.22	1.13	1.14
500	3.46	3.52	0.06	25.83	0.34	1.23	1.13	1.14

1. Total Loss = Insertion Loss + 3dB splitter loss.

ZFSC-2-1-S+ TOTAL LOSS

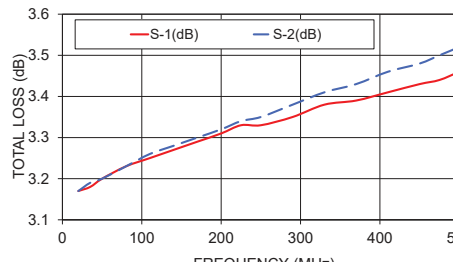

ZFSC-2-1-S+ VSWR

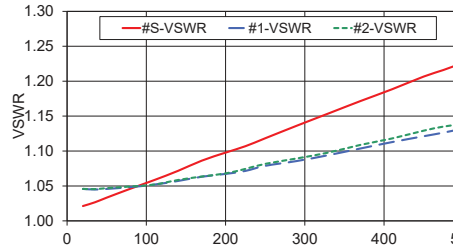

ZFSC-2-1-S+ ISOLATION

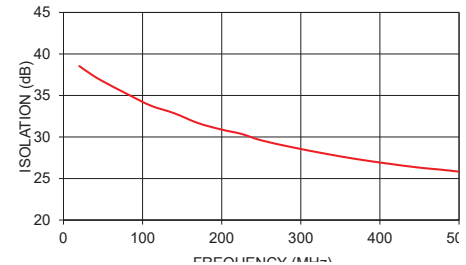

## electrical schematic



## Notes

- Performance and quality attributes and conditions not expressly stated in this specification document are intended to be excluded and do not form a part of this specification document.
- Electrical specifications and performance data contained in this specification document are based on Mini-Circuit's applicable established test performance criteria and measurement instructions.
- The parts covered by this specification document are subject to Mini-Circuits standard limited warranty and terms and conditions (collectively, "Standard Terms"); Purchasers of this part are entitled to the rights and benefits contained therein. For a full statement of the Standard Terms and the exclusive rights and remedies thereunder, please visit Mini-Circuits' website at [www.minicircuits.com/MCLStore/terms.jsp](http://www.minicircuits.com/MCLStore/terms.jsp)

