

INSULATED GATE BIPOLAR TRANSISTOR WITH ULTRAFAST SOFT RECOVERY DIODE

Features

- Low $V_{CE(on)}$ Trench IGBT Technology
- Low Switching Losses
- 5 μ s short circuit SOA
- Square RBSOA
- 100% of the parts tested for I_{LM} ①
- Positive $V_{CE(on)}$ Temperature Coefficient.
- Ultra Fast Soft Recovery Co-pak Diode
- Tighter Distribution of Parameters
- Lead-Free, RoHS Compliant
- Automotive Qualified *

Benefits

- High Efficiency in a Wide Range of Applications
- Suitable for a Wide Range of Switching Frequencies due to Low $V_{CE(ON)}$ and Low Switching Losses
- Rugged Transient Performance for Increased Reliability
- Excellent Current Sharing in Parallel Operation
- Low EMI

Applications

- Air Conditioning Compressor

n-channel

$V_{CES} = 600V$

$I_{C(Nominal)} = 24A$

$t_{SC} \geq 5\mu s, T_{J(max)} = 175^{\circ}C$

$V_{CE(on)} \text{ typ.} = 1.57V$

AUIRGB4062D1
TO-220AB

AUIRGS4062D1
D²Pak

AUIRGL4062D1
TO-262Pak

G	C	E
Gate	Collector	Emitter

Base Part Number	Package Type	Standard Pack		Orderable Part Number
		Form	Quantity	
AUIRGB4062D1	TO-220	Tube	50	AUIRGB4062D1
AUIRGL4062D1	TO-262	Tube	50	AUIRGL4062D1
AUIRGS4062D1	D² Pak	Tube	50	AUIRGS4062D1
		Tape and Reel Left	800	AUIRGS4062D1TRL
		Tape and Reel Right	800	AUIRGS4062D1TRR

Absolute Maximum Ratings

Stresses beyond those listed under "Absolute Maximum Ratings" may cause permanent damage to the device. These are stress ratings only; and functional operation of the device at these or any other condition beyond those indicated in the specifications is not implied. Exposure to absolute-maximum-rated conditions for extended periods may affect device reliability. The thermal resistance and power dissipation ratings are measured under board mounted and still air conditions. Ambient temperature (T_A) is 25°C, unless otherwise specified.

	Parameter	Max.	Units	
V_{CES}	Collector-to-Emitter Voltage	600	V	
$I_C @ T_C = 25^{\circ}C$	Continuous Collector Current	59	A	
$I_C @ T_C = 100^{\circ}C$	Continuous Collector Current	39		
$I_C (Nominal)$	Nominal Current	24		
I_{CM}	Pulse Collector Current $V_{GE} = 15V$	72		
I_{LM}	Clamped Inductive Load Current $V_{GE} = 20V$ ①	96		
$I_F @ T_C = 25^{\circ}C$	Diode Continuous Forward Current	59		
$I_F @ T_C = 100^{\circ}C$	Diode Continuous Forward Current	39		
I_{FM}	Maximum Repetitive Forward Current ②	96		
V_{GE}	Continuous Gate-to-Emitter Voltage	± 20		V
	Transient Gate-to-Emitter Voltage	± 30		
$P_D @ T_C = 25^{\circ}C$	Maximum Power Dissipation	246	W	
$P_D @ T_C = 100^{\circ}C$	Maximum Power Dissipation	123		
T_J	Operating Junction and	-55 to +175	°C	
T_{STG}	Storage Temperature Range			
	Soldering Temperature, for 10 sec.	300 (0.063 in.(1.6mm) from case)		
	Mounting Torque, 6-32 or M3 Screw	10 lbf·in (1.1 N·m)		

Thermal Resistance

	Parameter	Min.	Typ.	Max.	Units
$R_{\theta JC}$ (IGBT)	Thermal Resistance Junction-to-Case (IGBT) ③	—	—	0.61	°C/W
$R_{\theta JC}$ (Diode)	Thermal Resistance Junction-to-Case (Diode) ③	—	—	1.2	
$R_{\theta CS}$	Thermal Resistance, Case-to-Sink (flat, greased surface)	—	0.50	—	
$R_{\theta JA}$	Thermal Resistance, Junction-to-Ambient (typical socket mount)	—	62	—	

* Qualification standards can be found at www.infineon.com

Electrical Characteristics @ T_J = 25°C (unless otherwise specified)

	Parameter	Min.	Typ.	Max.	Units	Conditions
V _{(BR)CES}	Collector-to-Emitter Breakdown Voltage	600	—	—	V	V _{GE} = 0V, I _C = 100μA ^③
ΔV _{(BR)CES} /ΔT _J	Temperature Coeff. of Breakdown Voltage	—	0.3	—	V/°C	V _{GE} = 0V, I _C = 10mA (25°C-175°C)
V _{CE(on)}	Collector-to-Emitter Saturation Voltage	—	1.57	1.77	V	I _C = 24A, V _{GE} = 15V, T _J = 25°C
		—	1.87	—		I _C = 24A, V _{GE} = 15V, T _J = 150°C
		—	1.94	—		I _C = 24A, V _{GE} = 15V, T _J = 175°C
V _{GE(th)}	Gate Threshold Voltage	4.0	—	6.5	V	V _{CE} = V _{GE} , I _C = 700μA
ΔV _{GE(th)} /ΔT _J	Threshold Voltage temp. coefficient	—	-17	—	mV/°C	V _{CE} = V _{GE} , I _C = 1.0mA (25°C-175°C)
g _{fe}	Forward Transconductance	—	12	—	S	V _{CE} = 50V, I _C = 24A, PW = 20μs
I _{CES}	Collector-to-Emitter Leakage Current	—	1.0	25	μA	V _{GE} = 0V, V _{CE} = 600V
		—	3.5	—	mA	V _{GE} = 0V, V _{CE} = 600V, T _J = 175°C
V _{FM}	Diode Forward Voltage Drop	—	1.57	—	V	I _F = 24A
		—	1.40	—		I _F = 19A
		—	1.47	—		I _F = 24A, T _J = 175°C
I _{GES}	Gate-to-Emitter Leakage Current	—	—	±100	nA	V _{GE} = ±20V, V _{CE} = 0V

Switching Characteristics @ T_J = 25°C (unless otherwise specified)

	Parameter	Min.	Typ.	Max.	Units	Conditions
Q _g	Total Gate Charge (turn-on)	—	51	77	nC	I _C = 24A
Q _{ge}	Gate-to-Emitter Charge (turn-on)	—	14	21		V _{GE} = 15V
Q _{gc}	Gate-to-Collector Charge (turn-on)	—	21	32		V _{CC} = 400V
E _{on}	Turn-On Switching Loss	—	532	754	μJ	I _C = 24A, V _{CC} = 400V, V _{GE} = +15V, R _G = 10Ω, L = 210μH, T _J = 25°C
E _{off}	Turn-Off Switching Loss	—	311	526		
E _{total}	Total Switching Loss	—	843	1280		
t _{d(on)}	Turn-On delay time	—	19	36	ns	Energy losses include tail & diode reverse recovery
t _r	Rise time	—	24	41		
t _{d(off)}	Turn-Off delay time	—	90	109		
t _f	Fall time	—	23	40		
E _{on}	Turn-On Switching Loss	—	726	—	μJ	I _C = 24A, V _{CC} = 400V, V _{GE} = +15V, R _G = 10Ω, L = 210μH, T _J = 175°C ^③
E _{off}	Turn-Off Switching Loss	—	549	—		
E _{total}	Total Switching Loss	—	1275	—		
t _{d(on)}	Turn-On delay time	—	12	—	ns	Energy losses include tail & diode reverse recovery
t _r	Rise time	—	23	—		
t _{d(off)}	Turn-Off delay time	—	92	—		
t _f	Fall time	—	84	—		
C _{ies}	Input Capacitance	—	1487	—	pF	V _{GE} = 0V V _{CC} = 30V f = 1.0Mhz
C _{oes}	Output Capacitance	—	118	—		
C _{res}	Reverse Transfer Capacitance	—	44	—		
RBSOA	Reverse Bias Safe Operating Area	FULL SQUARE				T _J = 175°C, I _C = 96A V _{CC} = 480V, V _p ≤ 600V R _g = 10Ω, V _{GE} = +20V to 0V
SCSOA	Short Circuit Safe Operating Area	5	—	—	μs	V _{CC} = 400V, V _p ≤ 600V R _g = 10Ω, V _{GE} = +15V to 0V
E _{rec}	Reverse Recovery Energy of the Diode	—	773	—	μJ	T _J = 175°C
t _{rr}	Diode Reverse Recovery Time	—	102	—	ns	V _{CC} = 400V, I _F = 24A, V _{GE} = 15V,
I _{rr}	Peak Reverse Recovery Current	—	32	—	A	R _G = 10Ω, L = 210μH

Notes:

- ① V_{CC} = 80% (V_{CES}), V_{GE} = 20V, L = 210μH, R_G = 50Ω.
- ② Pulse width limited by max. junction temperature.
- ③ R_θ is measured at T_J of approximately 90°C.
- ④ Maximum limits are based on statistical sample size characterization.

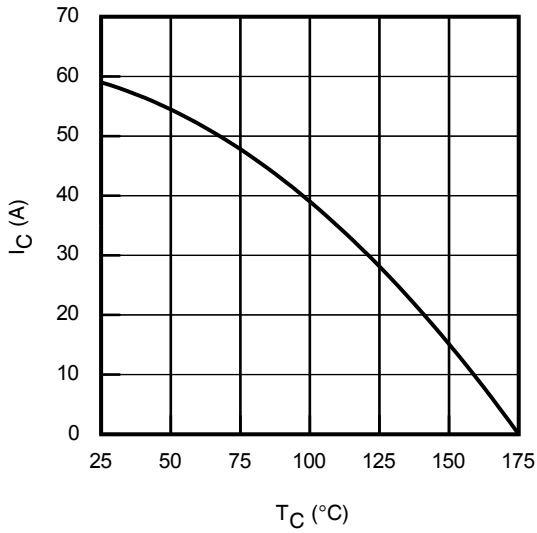

Fig. 1 - Maximum DC Collector Current vs. Case Temperature

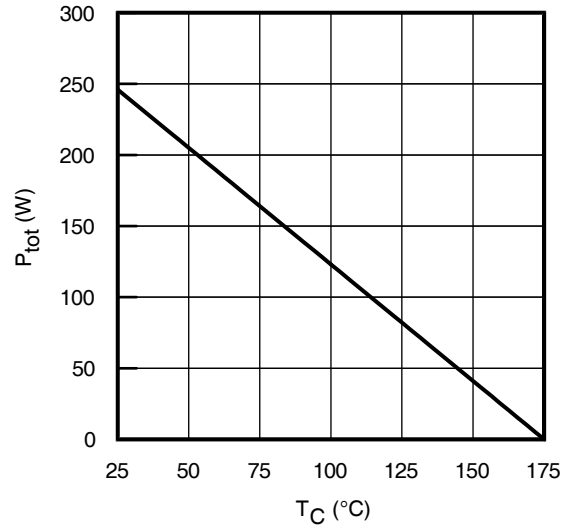

Fig. 2 - Power Dissipation vs. Case Temperature

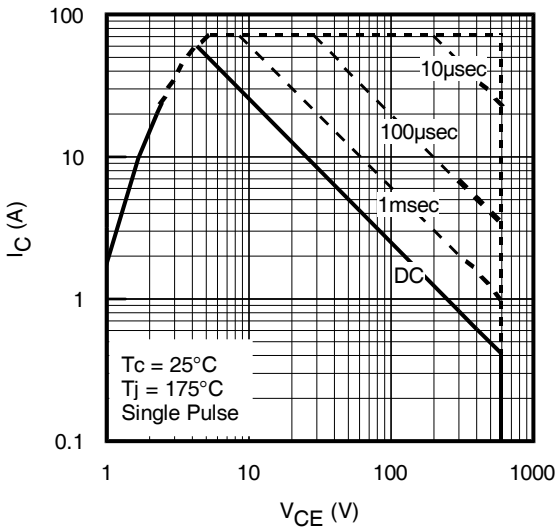

Fig. 3 - Forward SOA

$T_C = 25^\circ\text{C}$, $T_J \leq 175^\circ\text{C}$; $V_{GE} = 15\text{V}$

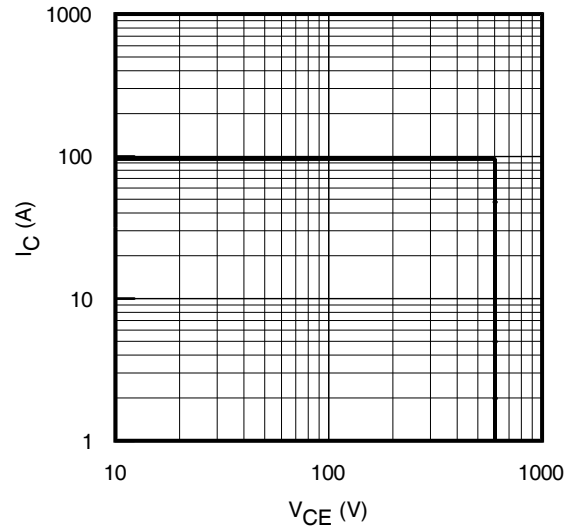

Fig. 4 - Reverse Bias SOA

$T_J = 175^\circ\text{C}$; $V_{GE} = 20\text{V}$

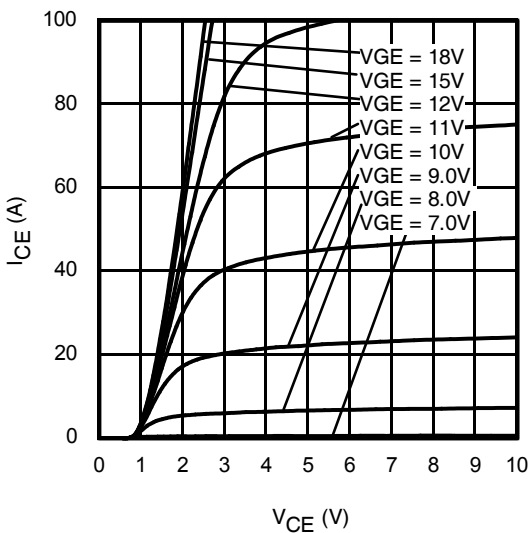

Fig. 5 - Typ. IGBT Output Characteristics

$T_J = -40^\circ\text{C}$; $t_p = 20\mu\text{s}$

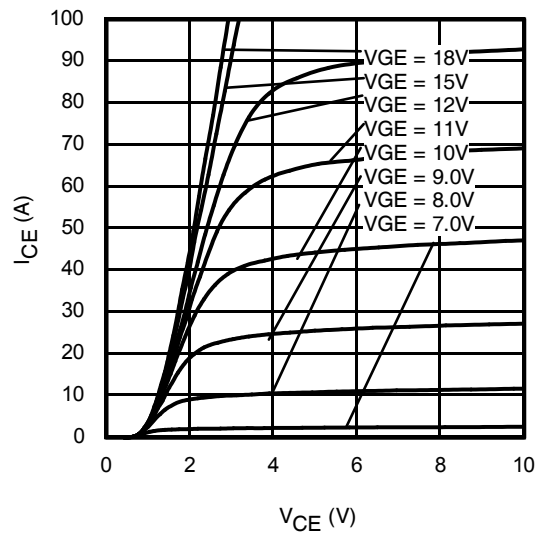

Fig. 6 - Typ. IGBT Output Characteristics

$T_J = 25^\circ\text{C}$; $t_p = 20\mu\text{s}$

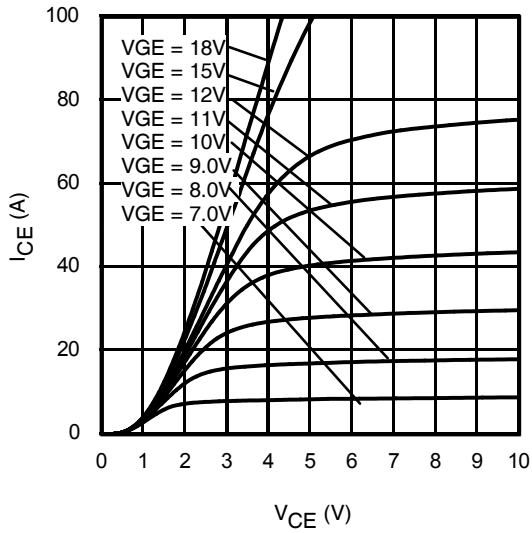

Fig. 7 - Typ. IGBT Output Characteristics
 $T_J = 175^\circ\text{C}$; $t_p = 20\mu\text{s}$

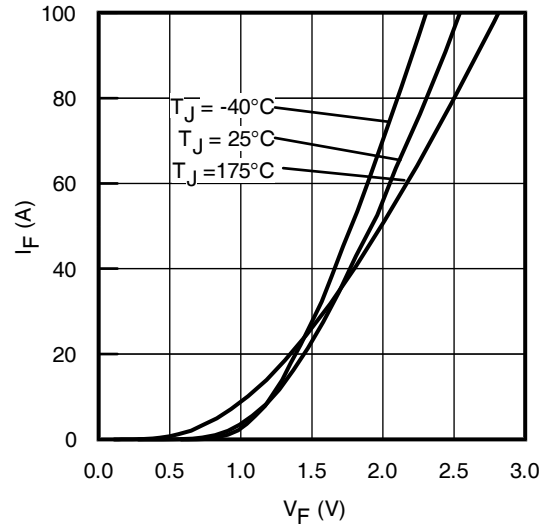

Fig. 8 - Typ. Diode Forward Characteristics
 $t_p = 20\mu\text{s}$

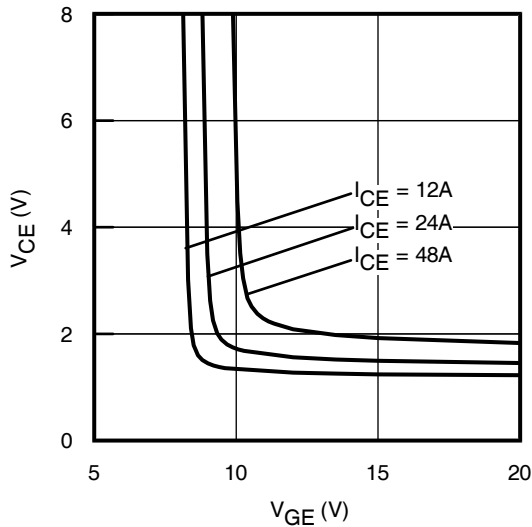

Fig. 9 - Typical V_{CE} vs. V_{GE}
 $T_J = -40^\circ\text{C}$

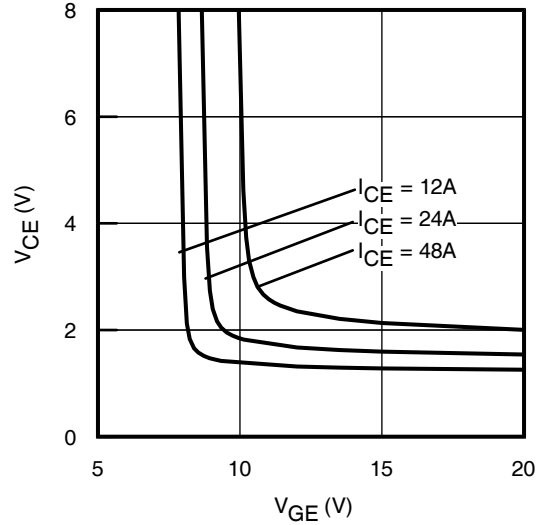

Fig. 10 - Typical V_{CE} vs. V_{GE}
 $T_J = 25^\circ\text{C}$

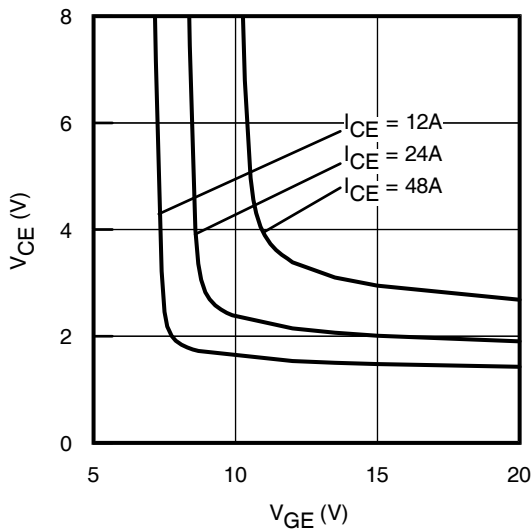

Fig. 11 - Typical V_{CE} vs. V_{GE}
 $T_J = 175^\circ\text{C}$

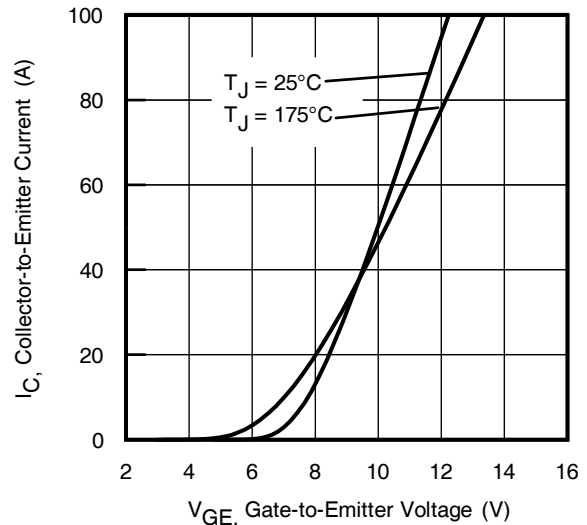
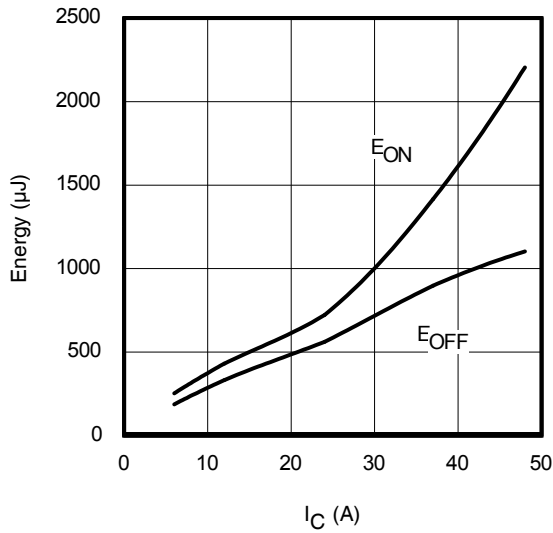
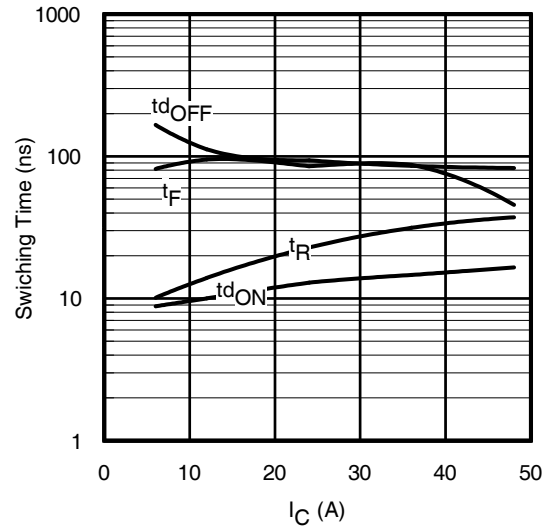
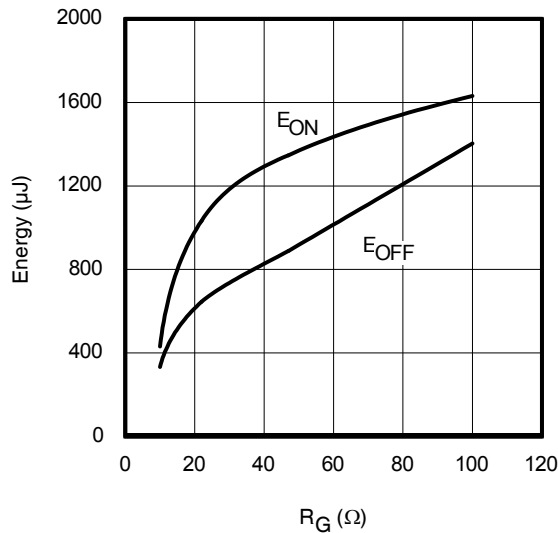
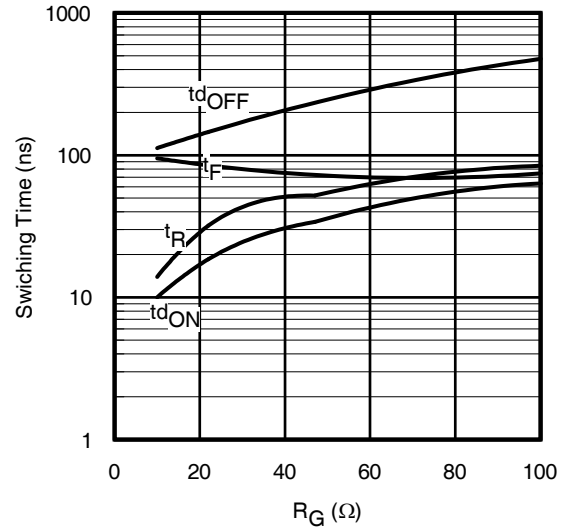
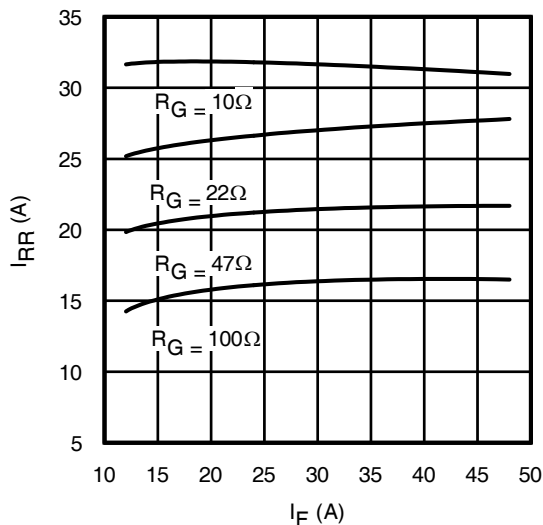
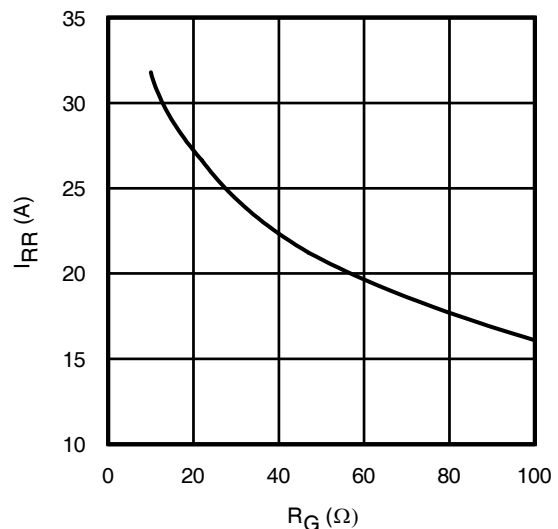

Fig. 12 - Typ. Transfer Characteristics
 $V_{CE} = 50\text{V}$; $t_p = 20\mu\text{s}$

Fig. 13 - Typ. Energy Loss vs. I_C
 $T_J = 175^\circ\text{C}; L = 210\mu\text{H}; V_{CE} = 400\text{V}, R_G = 10\Omega; V_{GE} = 15\text{V}$

Fig. 14 - Typ. Switching Time vs. I_C
 $T_J = 175^\circ\text{C}; L = 210\mu\text{H}; V_{CE} = 400\text{V}, R_G = 10\Omega; V_{GE} = 15\text{V}$

Fig. 15 - Typ. Energy Loss vs. R_G
 $T_J = 175^\circ\text{C}; L = 210\mu\text{H}; V_{CE} = 400\text{V}, I_{CE} = 24\text{A}; V_{GE} = 15\text{V}$

Fig. 16 - Typ. Switching Time vs. R_G
 $T_J = 175^\circ\text{C}; L = 210\mu\text{H}; V_{CE} = 400\text{V}, I_{CE} = 24\text{A}; V_{GE} = 15\text{V}$

Fig. 17 - Typ. Diode I_{RR} vs. I_F
 $T_J = 175^\circ\text{C}$

Fig. 18 - Typ. Diode I_{RR} vs. R_G
 $T_J = 175^\circ\text{C}$

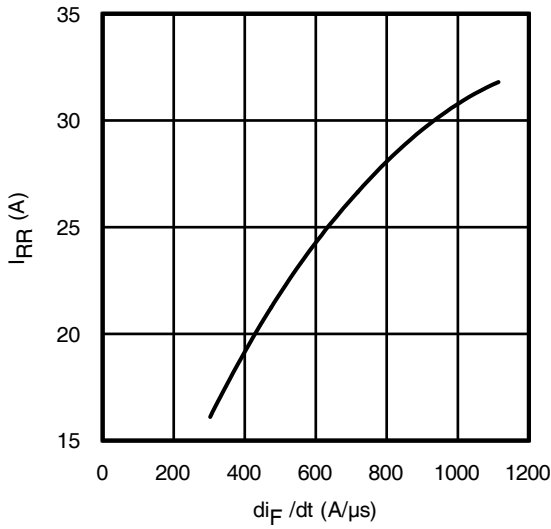

Fig. 19 - Typ. Diode I_{RR} vs. dI_F/dt
 $V_{CC} = 400V$; $V_{GE} = 15V$; $I_F = 24A$; $T_J = 175^\circ C$

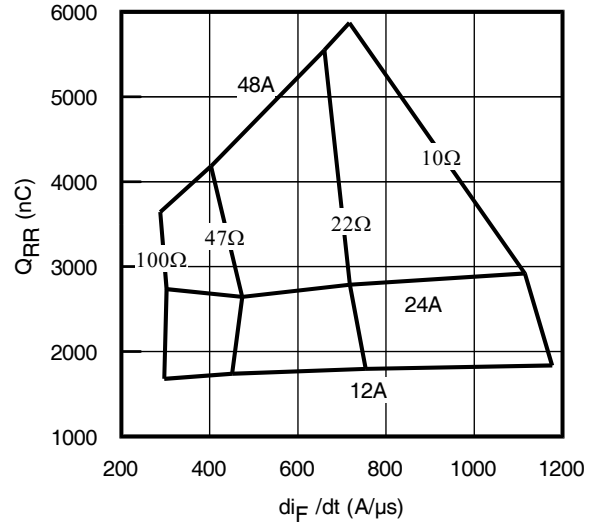

Fig. 20 - Typ. Diode Q_{RR} vs. dI_F/dt
 $V_{CC} = 400V$; $V_{GE} = 15V$; $T_J = 175^\circ C$

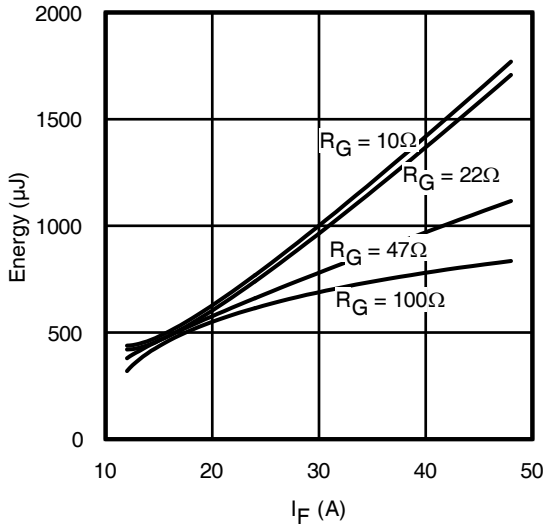

Fig. 21 - Typ. Diode E_{RR} vs. I_F
 $T_J = 175^\circ C$

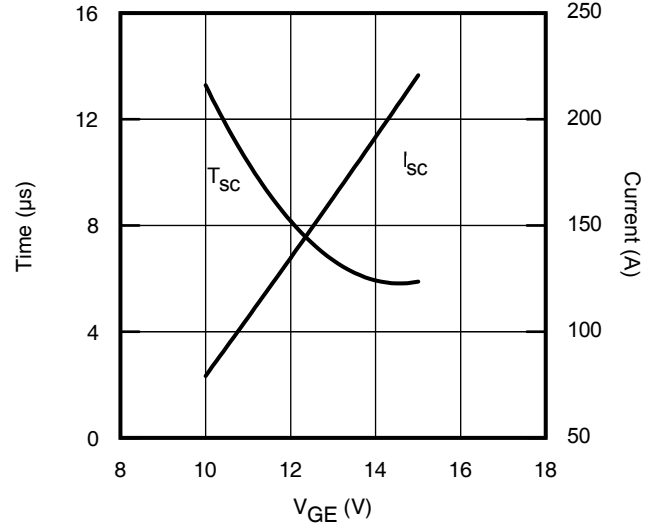

Fig. 22 - V_{GE} vs. Short Circuit Time
 $V_{CC} = 400V$; $T_C = 25^\circ C$

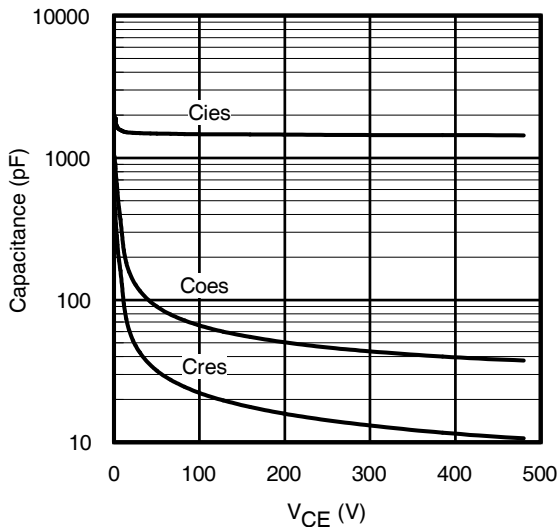

Fig. 23 - Typ. Capacitance vs. V_{CE}
 $V_{GE} = 0V$; $f = 1MHz$

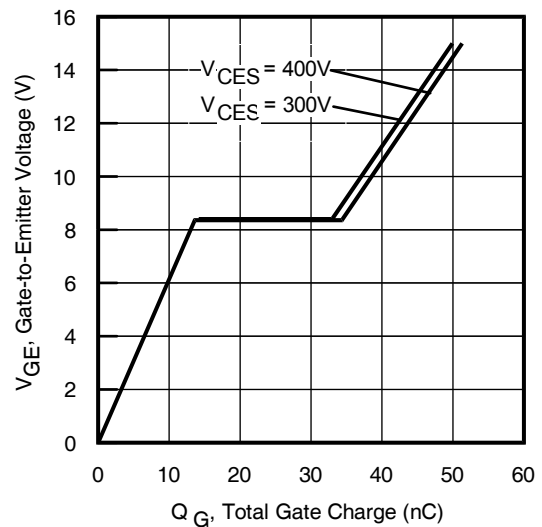
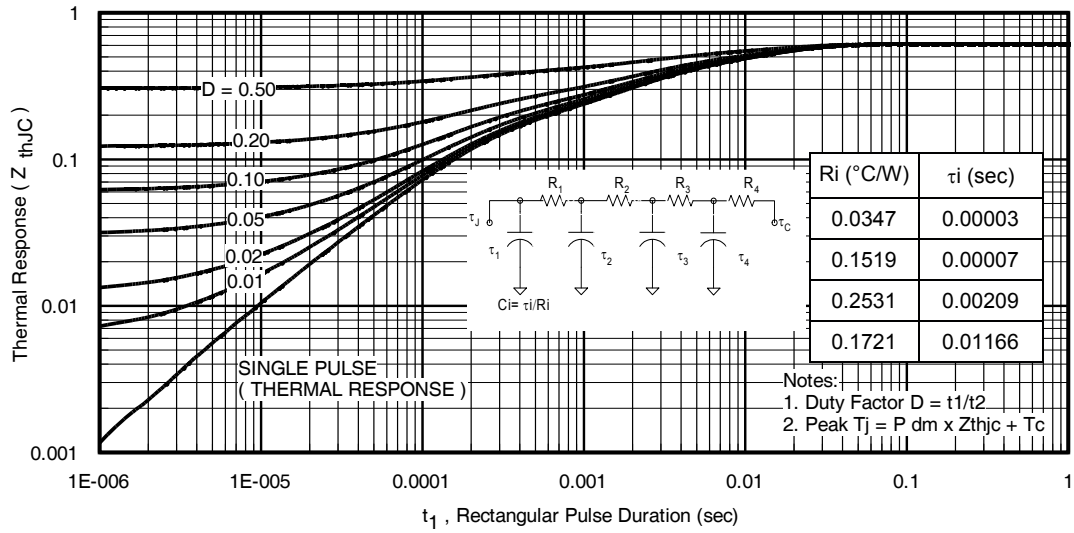
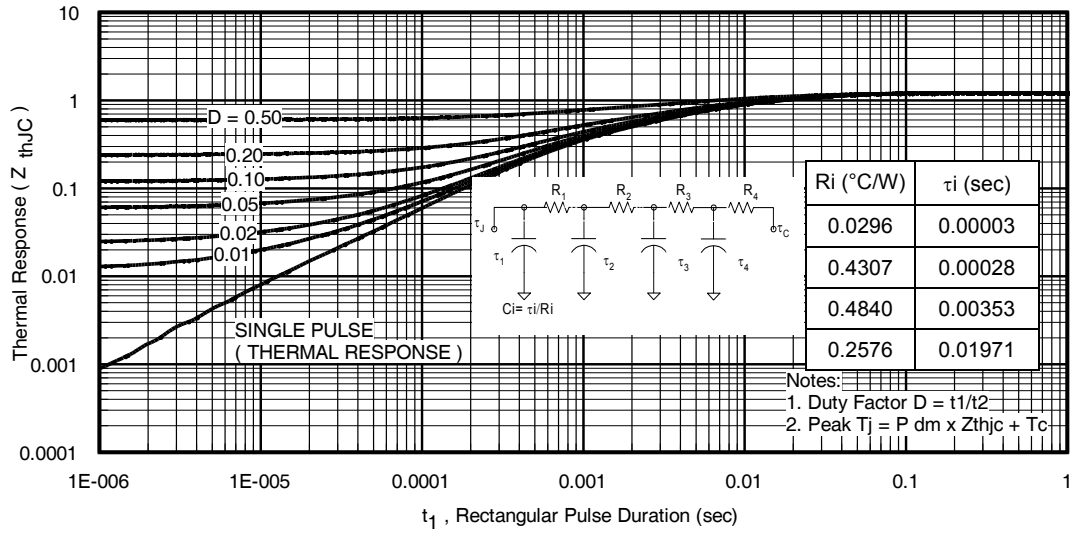
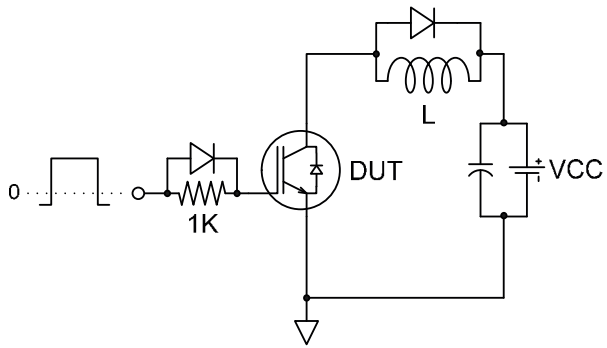
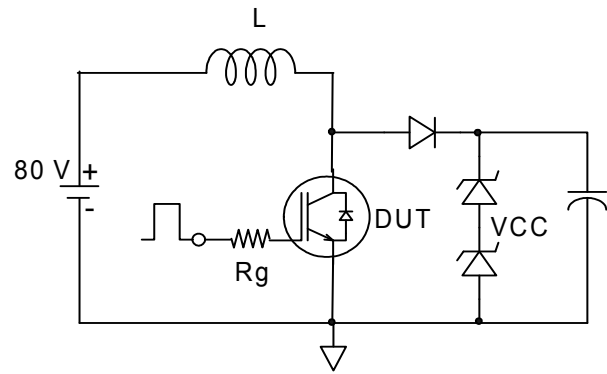
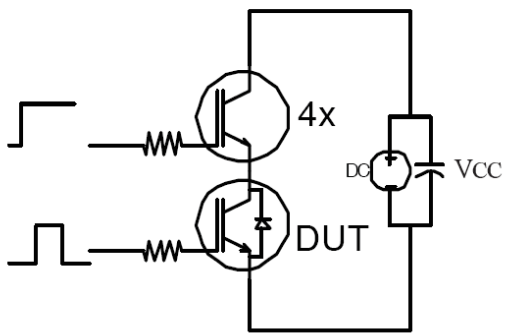
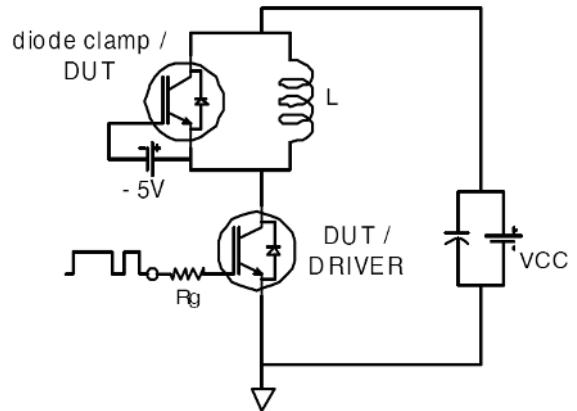
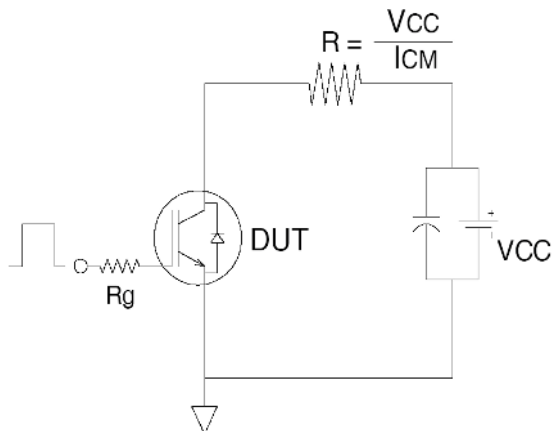

Fig. 24 - Typical Gate Charge vs. V_{GE}
 $I_{CE} = 24A$; $L = 585\mu H$

Fig 25. Maximum Transient Thermal Impedance, Junction-to-Case (IGBT)

Fig 26. Maximum Transient Thermal Impedance, Junction-to-Case (DIODE)

Fig.C.T.1 - Gate Charge Circuit (turn-off)

Fig.C.T.2 - RBSOA Circuit

Fig.C.T.3 - S.C. SOA Circuit

Fig.C.T.4 - Switching Loss Circuit

Fig.C.T.5 - Resistive Load Circuit

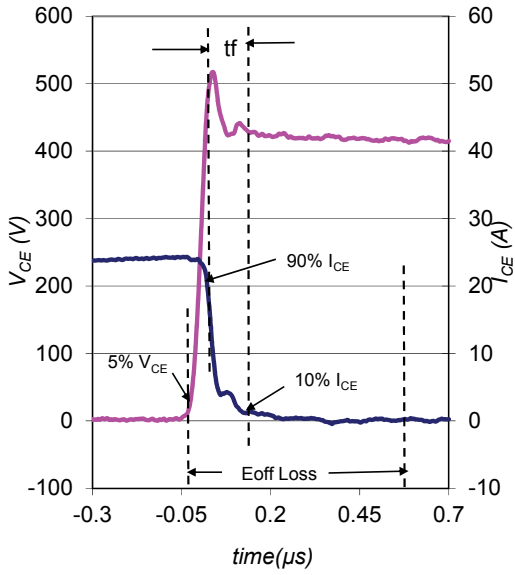

Fig. WF1 - Typ. Turn-off Loss Waveform
@ $T_J = 175^\circ\text{C}$ using Fig. CT.4

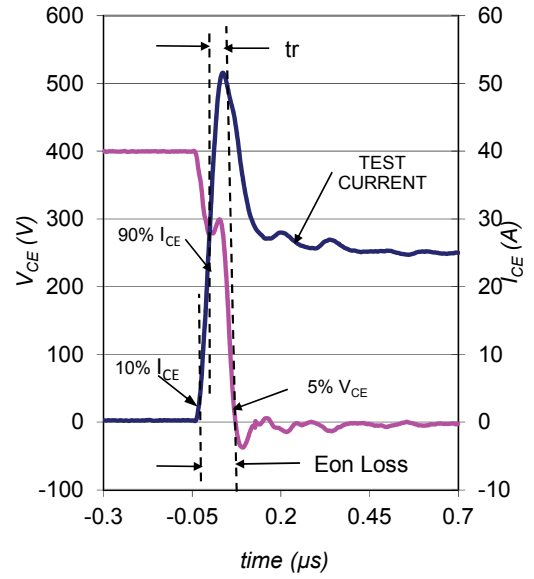

Fig. WF2 - Typ. Turn-on Loss Waveform
@ $T_J = 175^\circ\text{C}$ using Fig. CT.4

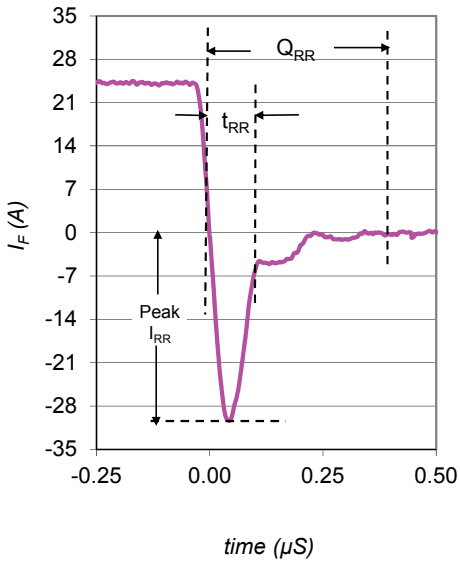

Fig. WF3 - Typ. Diode Recovery Waveform
@ $T_J = 175^\circ\text{C}$ using Fig. CT.4

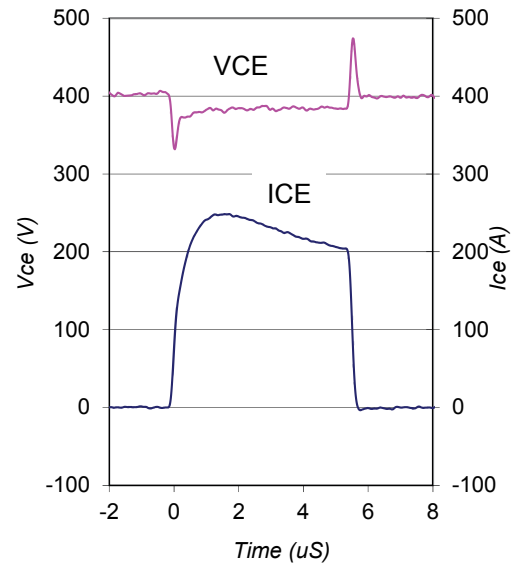
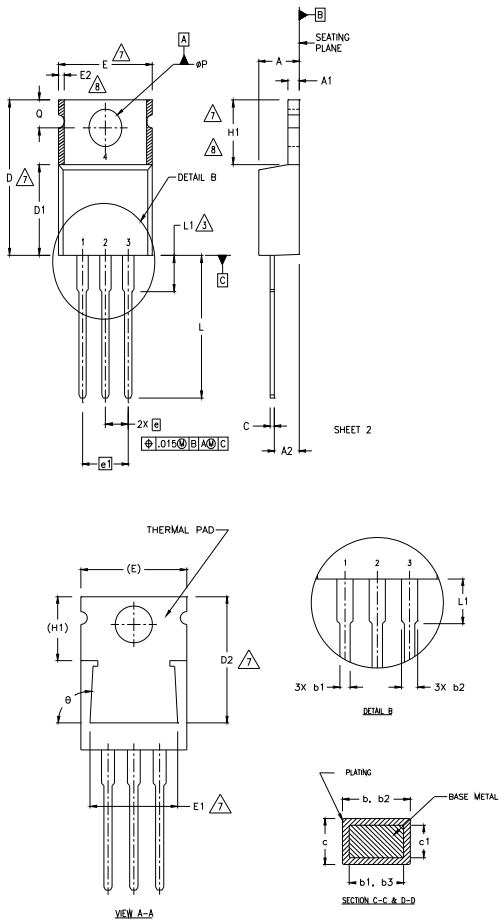

Fig. WF4 - Typ. S.C. Waveform
@ $T_J = 25^\circ\text{C}$ using Fig. CT.3

TO-220AB Package Outline

(Dimensions are shown in millimeters (inches))



NOTES:

- 1 DIMENSIONING AND TOLERANCING PER ASME Y14.5 M- 1994.
- 2 DIMENSIONS ARE SHOWN IN INCHES (MILLIMETERS).
- 3 LEAD DIMENSION AND FINISH UNCONTROLLED IN L1.
- 4 DIMENSION D & E DO NOT INCLUDE MOLD FLASH. MOLD FLASH SHALL NOT EXCEED .005" (0.127) PER SIDE. THESE DIMENSIONS ARE MEASURED AT THE OUTERMOST EXTREMES OF THE PLASTIC BODY.
- 5 DIMENSION b1 & c1 APPLY TO BASE METAL ONLY.
- 6 CONTROLLING DIMENSION : INCHES.
- 7 THERMAL PAD CONTOUR OPTIONAL WITHIN DIMENSIONS E,H1,D2 & E1
- 8 DIMENSION E2 X H1 DEFINE A ZONE WHERE STAMPING AND SINGULATION IRREGULARITIES ARE ALLOWED.

LEAD ASSIGNMENTS

HEFEET

- 1- GATE
- 2- DRAIN
- 3- SOURCE

ISBES_CoPACK

- 1- GATE
- 2- COLLECTOR
- 3- EMITTER

DIODES

- 1- ANODE/OPEN
- 2- CATHODE
- 3- ANODE

SYMBOL	DIMENSIONS				NOTES
	MILLIMETERS		INCHES		
	MIN.	MAX.	MIN.	MAX.	
A	3.56	4.82	.140	.190	
A1	0.51	1.40	.020	.055	
A2	2.04	2.92	.080	.115	
b	0.38	1.01	.015	.040	
b1	0.38	0.96	.015	.038	5
b2	1.15	1.77	.045	.070	
b3	1.15	1.73	.045	.068	
c	0.36	0.61	.014	.024	
c1	0.36	0.56	.014	.022	5
D	14.22	16.51	.560	.650	4
D1	8.38	9.02	.330	.355	
D2	12.19	12.88	.480	.507	7
E	9.66	10.66	.380	.420	4,7
E1	8.38	8.89	.330	.350	7
e	2.54 BSC		.100 BSC		
e1	5.08		.200 BSC		
H1	5.85	6.55	.230	.270	7,8
L	12.70	14.73	.500	.580	
L1	-	6.35	-	.250	3
øP	3.54	4.08	.139	.161	
Q	2.54	3.42	.100	.135	
ø	90°-93°		90°-93°		

TO-220AB Part Marking Information

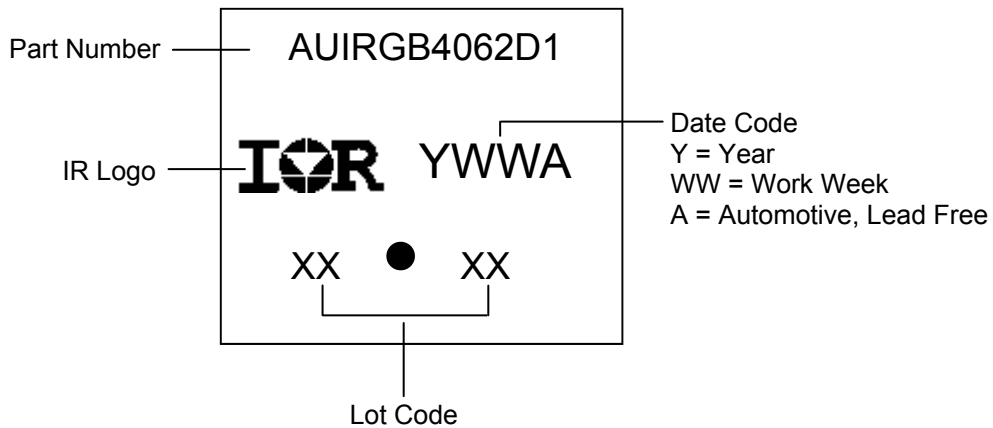

TO-220AC package is not recommended for Surface Mount Application.

D2 Pak (TO-263AB) Package Outline

(Dimensions are shown in millimeters (inches))

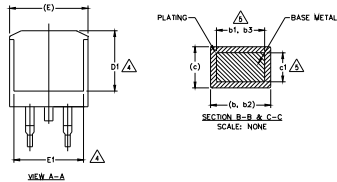
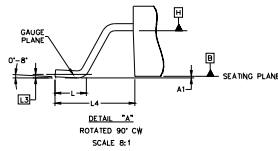
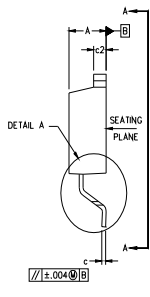
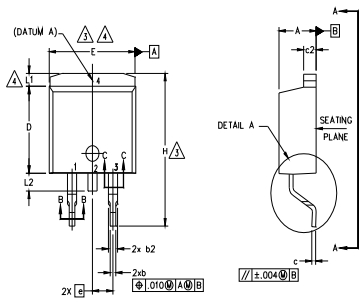

NOTES:

1. DIMENSIONING AND TOLERANCING PER ASME Y14.5M-1994
2. DIMENSIONS ARE SHOWN IN MILLIMETERS [INCHES].
3. DIMENSION D & E DO NOT INCLUDE MOLD FLASH. MOLD FLASH SHALL NOT EXCEED 0.127 [0.005"] PER SIDE. THESE DIMENSIONS ARE MEASURED AT THE OUTMOST EXTREMES OF THE PLASTIC BODY AT DATUM H.
4. THERMAL PAD CONTOUR OPTIONAL WITHIN DIMENSION E, L1, D1 & E1.
5. DIMENSION b1 AND c1 APPLY TO BASE METAL ONLY.
6. DATUM A & B TO BE DETERMINED AT DATUM PLANE H.
7. CONTROLLING DIMENSION: INCH.
8. OUTLINE CONFORMS TO JEDEC OUTLINE TO-263AB.

SYMBOL	DIMENSIONS				NOTES
	MILLIMETERS		INCHES		
	MIN.	MAX.	MIN.	MAX.	
A	4.06	4.83	.160	.190	
A1	0.00	0.254	.000	.010	
b	0.51	0.99	.020	.039	
b1	0.51	0.89	.020	.035	5
b2	1.14	1.78	.045	.070	
b3	1.14	1.73	.045	.068	5
c	0.38	0.74	.015	.029	
c1	0.38	0.58	.015	.023	5
c2	1.14	1.65	.045	.065	
D	8.38	9.65	.330	.380	3
D1	6.86	-	.270	-	4
E	9.65	10.67	.380	.420	3,4
E1	6.22	-	.245	-	4
e	2.54 BSC		.100 BSC		
H	14.61	15.88	.575	.625	
L	1.78	2.79	.070	.110	
L1	-	1.65	-	.066	4
L2	1.27	1.78	-	.070	
L3	0.25 BSC		.010 BSC		
L4	4.78	5.28	.188	.208	

LEAD ASSIGNMENTS

HEXFET

- 1.- GATE
- 2, 4.- DRAIN
- 3.- SOURCE

IGBTs, CoPACK

- 1.- GATE
- 2, 4.- COLLECTOR
- 3.- EMITTER

DIODES

- 1.- ANODE *
- 2, 4.- CATHODE
- 3.- ANODE

* PART DEPENDENT.

D2 Pak (TO-263AB) Part Marking Information

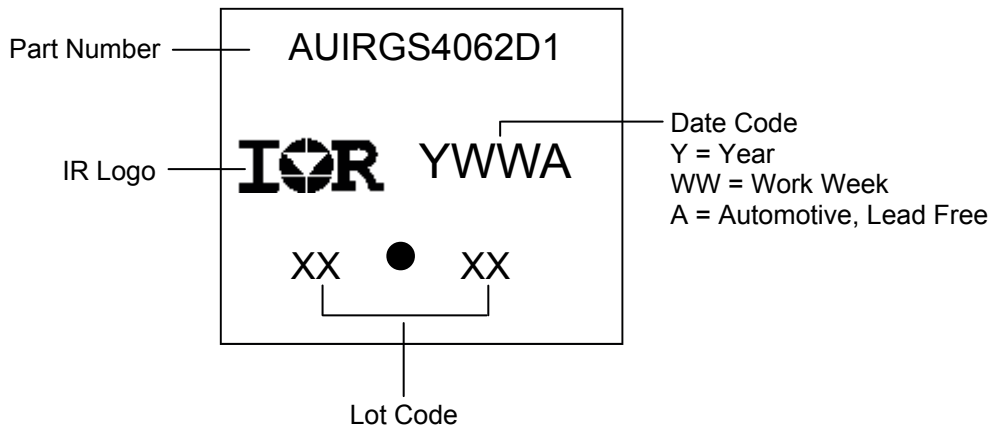

TO-262 Package Outline

(Dimensions are shown in millimeters (inches))

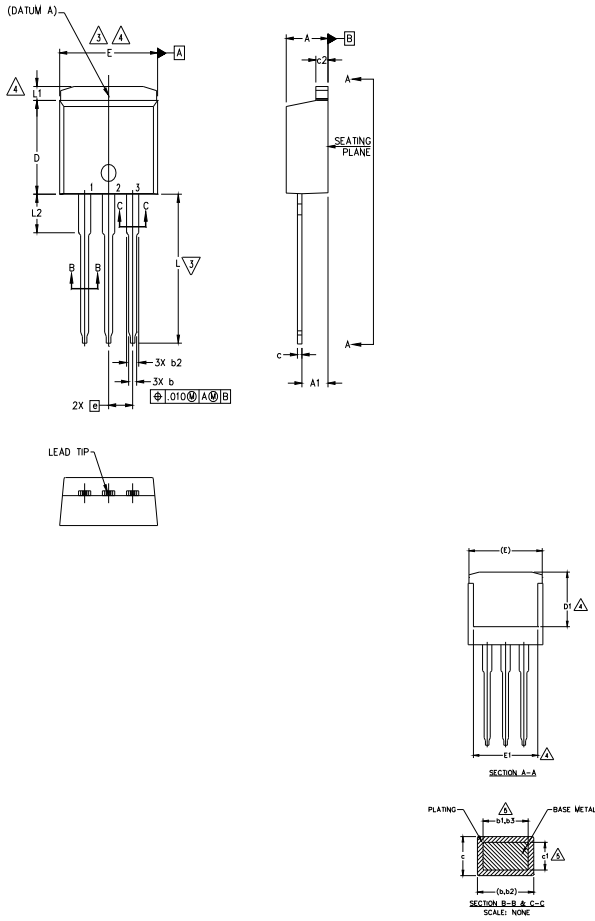

NOTES:

1. DIMENSIONING AND TOLERANCING PER ASME Y14.5M-1994
2. DIMENSIONS ARE SHOWN IN MILLIMETERS [INCHES].
3. DIMENSION D & E DO NOT INCLUDE MOLD FLASH. MOLD FLASH SHALL NOT EXCEED 0.127 [0.005"] PER SIDE. THESE DIMENSIONS ARE MEASURED AT THE OUTMOST EXTREMES OF THE PLASTIC BODY.
4. THERMAL PAD CONTOUR OPTIONAL WITHIN DIMENSION E, L1, D1 & E1.
5. DIMENSION b1 AND c1 APPLY TO BASE METAL ONLY.
6. CONTROLLING DIMENSION: INCH.
7. OUTLINE CONFORM TO JEDEC TO-262 EXCEPT A1(max.), b(min.) AND D1(min.) WHERE DIMENSIONS DERIVED THE ACTUAL PACKAGE OUTLINE.

SYMBOL	DIMENSIONS				NOTES
	MILLIMETERS		INCHES		
	MIN.	MAX.	MIN.	MAX.	
A	4.06	4.83	.160	.190	5
A1	2.03	3.02	.080	.119	
b	0.51	0.99	.020	.039	
b1	0.51	0.89	.020	.035	
b2	1.14	1.78	.045	.070	
b3	1.14	1.73	.045	.068	
c	0.38	0.74	.015	.029	
c1	0.38	0.58	.015	.023	
c2	1.14	1.65	.045	.065	
D	8.38	9.65	.330	.380	
D1	6.86	-	.270	-	4
E	9.65	10.67	.380	.420	3,4
E1	6.22	-	.245	-	4
e	2.54 BSC		.100 BSC		
L	13.46	14.10	.530	.555	4
L1	-	1.65	-	.065	
L2	3.56	3.71	.140	.146	

LEAD ASSIGNMENTS

HEXFET

- 1.- GATE
- 2.- DRAIN
- 3.- SOURCE
- 4.- DRAIN

IGBTs, CoPACK

- 1.- GATE
- 2.- COLLECTOR
- 3.- EMITTER
- 4.- COLLECTOR

TO-262 Part Marking Information

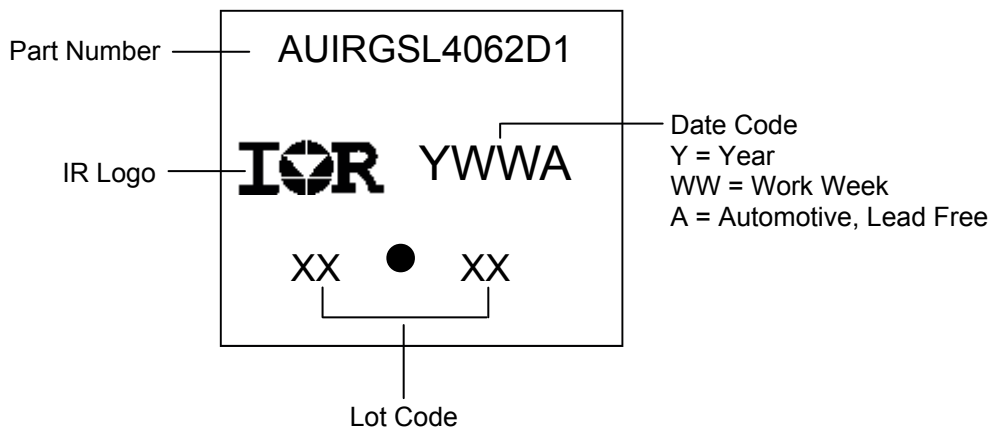

D2Pak Tape & Reel Information

(Dimensions are shown in millimeters (inches))

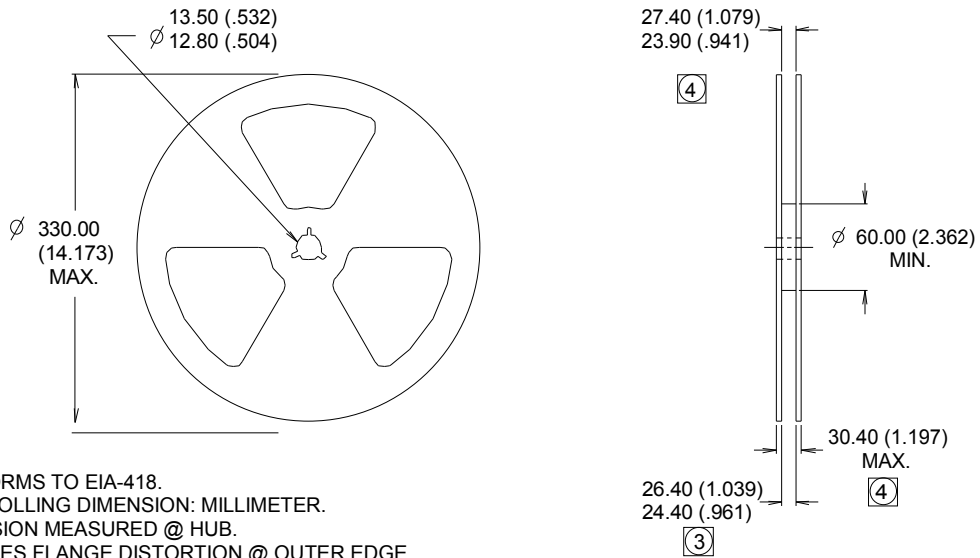
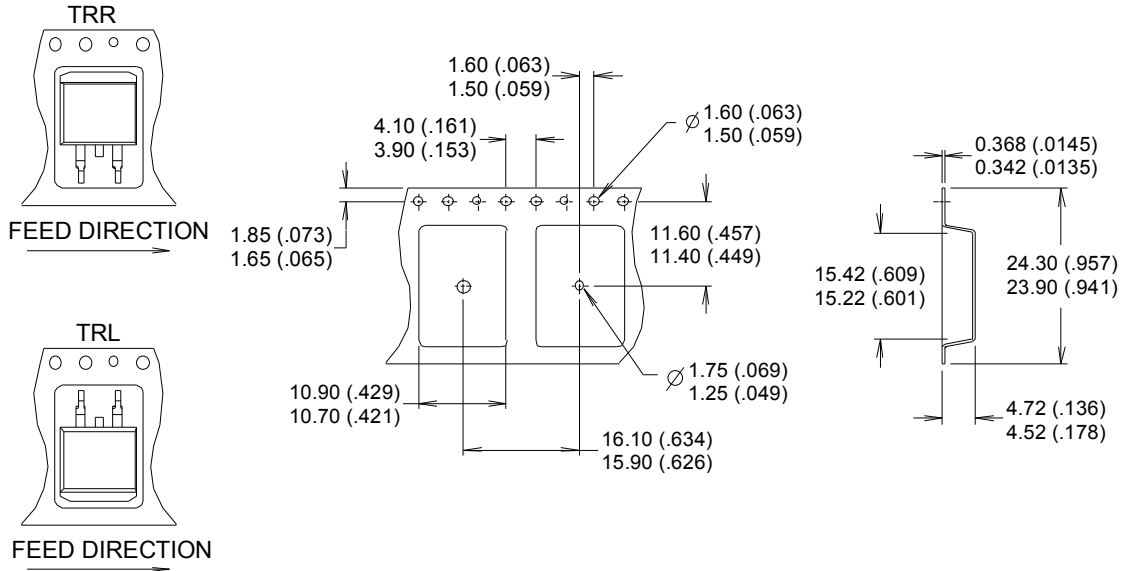

Qualification Information

Qualification Level		Automotive (per AEC-Q101)	
		This part number(s) passed Automotive qualification. Infineon's Industrial and Consumer qualification level is granted by extension of the higher Automotive level.	
Moisture Sensitivity Level		3L-TO-220	N/A
		3L-TO-262	
		3L-D2 PAK	MSL1
ESD	Machine Model	Class M4(+/- 700V) [†] AEC-Q101-002	
	Human Body Model	Class H1C(+/- 2000V) [†] AEC-Q101-001	
	Charged Device Model	Class C5 (+/- 2000V) [†] AEC-Q101-005	
RoHS Compliant		Yes	

† Highest passing voltage.

Revision History

Date	Comments
8/31/2017	<ul style="list-style-type: none"> Updated datasheet with corporate template Corrected part marking on pages 10,11, 12

Published by
Infineon Technologies AG
81726 München, Germany
© Infineon Technologies AG 2015
All Rights Reserved.
IMPORTANT NOTICE

The information given in this document shall in no event be regarded as a guarantee of conditions or characteristics ("Beschaffenheitsgarantie"). With respect to any examples, hints or any typical values stated herein and/or any information regarding the application of the product, Infineon Technologies hereby disclaims any and all warranties and liabilities of any kind, including without limitation warranties of non-infringement of intellectual property rights of any third party.

In addition, any information given in this document is subject to customer's compliance with its obligations stated in this document and any applicable legal requirements, norms and standards concerning customer's products and any use of the product of Infineon Technologies in customer's applications.

The data contained in this document is exclusively intended for technically trained staff. It is the responsibility of customer's technical departments to evaluate the suitability of the product for the intended application and the completeness of the product information given in this document with respect to such application.

For further information on the product, technology, delivery terms and conditions and prices please contact your nearest Infineon Technologies office (www.infineon.com).

WARNINGS

Due to technical requirements products may contain dangerous substances. For information on the types in question please contact your nearest Infineon Technologies office.

Except as otherwise explicitly approved by Infineon Technologies in a written document signed by authorized representatives of Infineon Technologies, Infineon Technologies' products may not be used in any applications where a failure of the product or any consequences of the use thereof can reasonably be expected to result in personal injury.