

	10	9	8	7	6	5	4	3	2	1
	MATERIAL NO. LOOSE PIECE	ENGINEERING P/N LOOSE	MATERIAL NO. TAPE MOUNTED	ENGINEERING P/N TAPED	STUD SIZE	"S" ±.005/0.13	"W" MAX.	"C" MIN.	"L" MAX.	"H" ±.02 /0.5
F	191930303	G-375-10	191930958	G-375-10T	10	.198/5.03	.645/16.38	.703/17.86	1.583/40.21	.43/10.9
	191930305	G-375-14	191930959	G-375-14T	1/4"	.265/6.73	.645/16.38	.703/17.86	1.583/40.21	.43/10.9
	191930309	G-375-56	191930960	G-375-56T	5/16"	.328/8.33	.645/16.38	.703/17.86	1.583/40.21	.43/10.9
	191930307	G-375-38	191930961	G-375-38T	3/8"	.390/9.91	.645/16.38	.703/17.86	1.583/40.21	.43/10.9
	191930311	G-375-76	-	-	7/16"	.453/11.51	.645/16.38	.703/17.86	1.583/40.21	-
	191930297	G-374-14	-	-	1/4"	.265/6.73	.879/22.33	.703/17.86	1.700/43.18	-
	191930299	G-374-56	-	-	5/16"	.328/8.33	.879/22.33	.703/17.86	1.700/43.18	-
	191930298	G-374-38	-	-	3/8"	.390/9.91	.879/22.33	.703/17.86	1.700/43.18	-
E	191930302	G-374-76	191930991	G-374-76T	7/16"	.453/11.51	.879/22.33	.703/17.86	1.700/43.18	.31/7.9
	191930296	G-374-12	191930962	G-374-12T	1/2"	.515/13.08	.879/22.33	.703/17.86	1.700/43.18	.31/7.9
	191930301	G-374-58	191930963	G-374-58T	5/8"	.653/16.59 (C)	.879/22.33	.703/17.86	1.700/43.18	.31/7.9
	191930313	G-376-14	-	-	1/4"	.265/6.73	.895/22.73	.990/25.15	1.995/50.67	-
	191930315	G-376-56	-	-	5/16"	.328/8.33	.895/22.73	.990/25.15	1.995/50.67	-
	191930314	G-376-38	-	-	3/8"	.390/9.91	.895/22.73	.990/25.15	1.995/50.67	-
	191930317	G-376-76	-	-	7/16"	.453/11.51	.895/22.73	.990/25.15	1.995/50.67	-
D	191930312	G-376-12	-	-	1/2"	.515/13.08	.895/22.73	.990/25.15	1.995/50.67	-
	191930316	G-376-58	-	-	5/8"	.656/16.66	.895/22.73	.990/25.15	1.995/50.67	-
	191930319	G-377-14	-	-	1/4"	.265/6.73	1.270/32.26	.990/25.15	2.183/55.45	-
	191930322	G-377-56	-	-	5/16"	.328/8.33	1.270/32.26	.990/25.15	2.183/55.45	-
	191930321	G-377-38	-	-	3/8"	.390/9.91	1.270/32.26	.990/25.15	2.183/55.45	-
	191930324	G-377-76	-	-	7/16"	.453/11.51	1.270/32.26	.990/25.15	2.183/55.45	-
	191930318	G-377-12	-	-	1/2"	.515/13.08	1.270/32.26	.990/25.15	2.183/55.45	-
C	191930611	G-377-58	-	-	5/8"	.656/16.66	1.270/32.26	.990/25.15	2.183/55.45	-
	191930320	G-377-34	-	-	3/4"	.781/19.84	1.270/32.26	.990/25.15	2.183/55.45	-

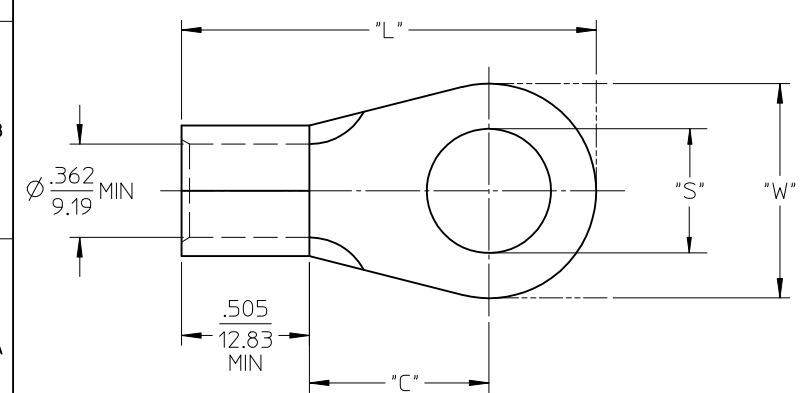
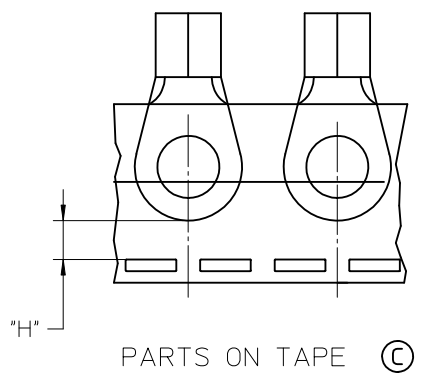

- NOTES:
1. MATERIAL: MATTE-TIN PLATED COPPER
 2. WIRE SIZE: 2 AWG/ 26.6-42.4 mm²
 3. PARTS ARE ROHS COMPLIANT.

SALES DRAWING

REDRAWN FROM SD-19193-007, -028, -029, -030
DRAWN BY DLM 07/2003

CONSOL. ADD TAPE EC NO: WNA2011-0538 DRAWN: ETHRODAHL 2011/05/05 CHKD: JMACNEIL 2011/05/05 APPR: JMACNEIL 2011/06/03	DESCRIPTION REV	QUALITY SYMBOLS ▽=0 ▽=0	GENERAL TOLERANCES (UNLESS SPECIFIED)	DIMENSION STYLE IN/MM	SCALE ---	DESIGN UNITS INCH	THIRD ANGLE PROJECTION		
		4 PLACES ± --- ± --- 3 PLACES ± --- ± .005 2 PLACES ± 0.13 ± .010 1 PLACE ± 0.25 ± .020	DRAWN BY DATE ETHRODAHL 2011/05/05	CHECKED BY DATE JMACNEIL 2011/05/05	APPROVED BY DATE JMACNEIL 2011/06/03	TITLE RING TONGUE TERMINAL VERSAKRIMP, 2 AWG			
		ANGULAR ± ---°	MATERIAL NO. SEE CHART	DOCUMENT NO. SD-19193-038	MOLEX INCORPORATED				
		DRAFT WHERE APPLICABLE MUST REMAIN WITHIN DIMENSIONS	SIZE B	THIS DRAWING CONTAINS INFORMATION THAT IS PROPRIETARY TO MOLEX INCORPORATED AND SHOULD NOT BE USED WITHOUT WRITTEN PERMISSION					