

## RF front-end for AM/FM DSP car-radio with IF sampling

### Features

- Fully integrated VCO for world tuning
- High performance PLL for fast RDS system
- I/Q mixer for FM IF 10.7 MHz with image rejection and integrated LNA
- I/Q mixer for AM IF 10.7 MHz up conversion with high dynamic range
- Integrated balun, which allows saving of external mixer tank
- RF AGC, IF AGC, DAGC
- Low noise IF amplifier with switched wide dynamic AGC range
- IF switch for FM / AM / IBOC
- Electronic alignment for the preselection stages
- I<sup>2</sup>C/SPI controlled
- Single 5 V supply
- Alternative frequency control signals to DSP

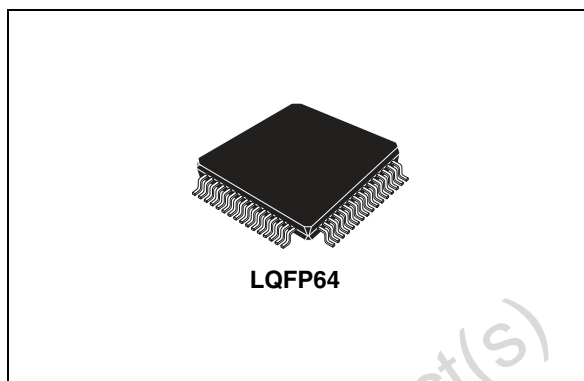

### Description

The front-end is a high performance tuner circuit for AM/FM - DSP car radios with 10.7 MHz IF sampling. It contains mixer and IF amplifiers for AM and FM, fully integrated VCO and PLL synthesizer on a single chip. Use of BiCMOS technology allows the implementation of several tuning functions and a minimum of external components.

**Table 1. Device summary**

Order code	Package	Packing
TDA7529	LQFP64 exposed pad (10x10x1.4)	Tray
TDA7529TH	LQFP64 exposed pad (10x10x1.4)	Tape and reel

# Contents

- 1      Functional block diagram ..... 8**
- 2      Pin description ..... 9**
- 3      Function description ..... 12**
  - 3.1    IMR mixer and active balun output ..... 12
  - 3.2    FM RF-AGC ..... 12
  - 3.3    AM RF-AGC ..... 13
  - 3.4    IF AGC and IF amplifier ..... 14
  - 3.5    Dividers ..... 14
  - 3.6    D/A converters ..... 14
  - 3.7    VCO ..... 15
  - 3.8    FREF ..... 15
  - 3.9    A/D converter ..... 15
  - 3.10   GPIO - general purpose IO interface pins ..... 16
  - 3.11   AFSAMPLE/AFHOLD ..... 17
  - 3.12   Serial bus interface ..... 17
- 4      Electrical specifications ..... 19**
  - 4.1    Absolute maximum ratings ..... 19
  - 4.2    Thermal data ..... 19
  - 4.3    General key parameters ..... 19
  - 4.4    FM - section ..... 20
  - 4.5    AM - section ..... 21
  - 4.6    IF - section ..... 22
  - 4.7    VCO ..... 24
  - 4.8    Reference frequency input buffer ..... 24
  - 4.9    Dividers ..... 24
  - 4.10   Phase locked loop ..... 25
  - 4.11   Phase frequency detector and charge pump ..... 25
  - 4.12   Temperature sensor ..... 26
  - 4.13   D/A-converter ..... 26

4.14	A/D-converter .....	26
4.15	GPIO – general purpose IO interface pins .....	27
4.16	AFSAMPLE / AFHOLD .....	27
4.17	Serial data interface .....	28
<b>5</b>	<b>Tuning state machine .....</b>	<b>29</b>
5.1	Tuning state machine modes .....	29
5.1.1	Mode 000: buffer (nil) .....	29
5.1.2	Mode 001: preset .....	29
5.1.3	Mode 010: search .....	30
5.1.4	Mode 011: AF update .....	30
5.1.5	Mode 100: jump .....	31
5.2	Mode 100: check .....	31
5.3	Mode 110: load .....	32
5.4	Mode 111: end .....	32
5.5	Register SWAP .....	33
5.6	State machine start .....	34
<b>6</b>	<b>Registers description .....</b>	<b>35</b>
6.1	Data byte specification .....	36
6.1.1	Short_reg (0) .....	36
6.1.2	ADCctrl (1) .....	37
6.1.3	GPIO mode (2) .....	38
6.1.4	AGC and mixer control (3) .....	39
6.1.5	Register (4) .....	40
6.1.6	Divider R (5) .....	40
6.1.7	IF AGC control (6) .....	41
6.1.8	FM AGC (7) .....	42
6.1.9	AGC voltage threshold (8) .....	43
6.1.10	Mixer alignment 1 (9) .....	43
6.1.11	Mixer alignment 2 (10) .....	44
6.1.12	PLL control 1 (11) .....	45
6.1.13	PLL control 2 (12) .....	45
6.1.14	PLL test (13) .....	46
6.1.15	Misc 2 (14) .....	46
6.1.16	Wait lock (15) .....	47

6.1.17	AGC time constant settings (16 / 32)	47
6.1.18	AMAGC control (17 / 33)	48
6.1.19	GPIO output level control (18 / 34)	49
6.1.20	IF control (19 / 35)	49
6.1.21	AF state machine wait time 1 (20 / 36)	50
6.1.22	PLL main divider (N-divider) 1 (21 / 37)	50
6.1.23	PLL main divider (N-divider) 2 (22 / 38)	50
6.1.24	PLL main divider (N-divider) 3 (23 / 39)	51
6.1.25	PLL Divider ratio calculation	51
6.1.26	VCO divider (V-divider) (24 / 40)	51
6.1.27	Charge pump current (25 / 41)	52
6.1.28	Tuning DAC 1 (26 / 42)	52
6.1.29	Tuning DAC 2 (27 / 43)	53
6.1.30	Different controls (28 / 44)	53
6.1.31	Misc 3 (29 / 45)	54
6.1.32	Analog test select (30 / 46)	54
6.1.33	AD converter test (31 / 47)	55
6.1.34	Read 1 (48)	55
6.1.35	Read 2 (49)	56
<b>7</b>	<b>Application schematic</b>	<b>57</b>
<b>8</b>	<b>Package information</b>	<b>58</b>
<b>9</b>	<b>Revision history</b>	<b>59</b>

## List of tables

Table 1.	Device summary . . . . .	1
Table 2.	Pin assignment . . . . .	9
Table 3.	IF AGC and IF amplifier . . . . .	14
Table 4.	Switching frequency as a function of the process. . . . .	15
Table 5.	GPIO - general purpose IO interface pins . . . . .	16
Table 6.	Supports data communication using the SPI and the I <sup>2</sup> C protocol. . . . .	17
Table 7.	I <sup>2</sup> C addresses . . . . .	18
Table 8.	Absolute maximum ratings . . . . .	19
Table 9.	Thermal data. . . . .	19
Table 10.	General key parameters . . . . .	19
Table 11.	FM - section . . . . .	20
Table 12.	AM - section . . . . .	21
Table 13.	IF - section . . . . .	22
Table 14.	VCO . . . . .	24
Table 15.	Reference frequency input buffer . . . . .	24
Table 16.	Dividers. . . . .	24
Table 17.	Phase Locked Loop . . . . .	25
Table 18.	Phase frequency detector and charge pump . . . . .	25
Table 19.	Temperature sensor . . . . .	26
Table 20.	D/A-converter . . . . .	26
Table 21.	A/D-converter . . . . .	26
Table 22.	GPIO - general purpose IO interface pins . . . . .	27
Table 23.	AFSAMPLE / AFHOLD . . . . .	27
Table 24.	Serial data interface . . . . .	28
Table 25.	Values of the programmable wait times . . . . .	33
Table 26.	Short_reg (0) . . . . .	36
Table 27.	ADCctrl (1) . . . . .	37
Table 28.	GPIO mode (2) . . . . .	38
Table 29.	AGC and mixer control (3) . . . . .	39
Table 30.	Register (4) . . . . .	40
Table 31.	Divider R (5) . . . . .	40
Table 32.	IF AGC control (6) . . . . .	41
Table 33.	FM AGC (7) . . . . .	42
Table 34.	AGC voltage threshold (8) . . . . .	43
Table 35.	Mixer alignment 1 (9) . . . . .	43
Table 36.	Mixer alignment 2 (10) . . . . .	44
Table 37.	PLL control 1 (11) . . . . .	45
Table 38.	PLL control 2 (12) . . . . .	45
Table 39.	PLL test (13) . . . . .	46
Table 40.	Misc 2 (14) . . . . .	46
Table 41.	Wait lock (15) . . . . .	47
Table 42.	AGC time constant settings (16 / 32) . . . . .	47
Table 43.	AMAGC control (17 / 33) . . . . .	48
Table 44.	GPIO output level control (18 / 34) . . . . .	49
Table 45.	IF control (19 / 35) . . . . .	49
Table 46.	AF state machine wait time 1 (20 / 36) . . . . .	50
Table 47.	PLL main divider (N-divider) 1 (21 / 37) . . . . .	50
Table 48.	PLL main divider (N-divider) 2 (22 / 38) . . . . .	50

Table 49.	PLL main divider (N-divider) 3 (23 / 39)	51
Table 50.	PLL Divider ratio calculation	51
Table 51.	VCO divider (V-divider) (24 / 40)	51
Table 52.	Charge pump current (25 / 41)	52
Table 53.	Tuning DAC 1 (26 / 42)	52
Table 54.	Tuning DAC 2 (27 / 43)	53
Table 55.	Different controls (28 / 44)	53
Table 56.	Misc 3 (29 / 45)	54
Table 57.	Analog test select (30 / 46)	54
Table 58.	AD converter test (31 / 47)	55
Table 59.	Read 1 (48)	55
Table 60.	Read 2 (49)	56
Table 61.	Document revision history	59

Obsolete Product(s) - Obsolete Product(s)

## List of figures

Figure 1.	Functional block diagram . . . . .	8
Figure 2.	Pin connection . . . . .	9
Figure 3.	Positive current diagram . . . . .	12
Figure 4.	Positive/negative current diagram . . . . .	13
Figure 5.	Voltage and current mode with hand-over . . . . .	13
Figure 6.	I <sup>2</sup> C (sub address mode) . . . . .	18
Figure 7.	SPI . . . . .	18
Figure 8.	Preset timing diagram . . . . .	29
Figure 9.	Search timing diagram . . . . .	30
Figure 10.	AF update timing diagram . . . . .	30
Figure 11.	Jump timing diagram . . . . .	31
Figure 12.	Check timing diagram . . . . .	31
Figure 13.	Load timing diagram . . . . .	32
Figure 14.	End timing diagram . . . . .	32
Figure 15.	Buffer/control serial bus sequence . . . . .	34
Figure 16.	Registers description . . . . .	35
Figure 17.	Application schematic . . . . .	57
Figure 18.	LQFP64 (10x10x1.4mm) exposed pad down mechanical data and package dimensions .	58

# 1 Functional block diagram

Figure 1. Functional block diagram

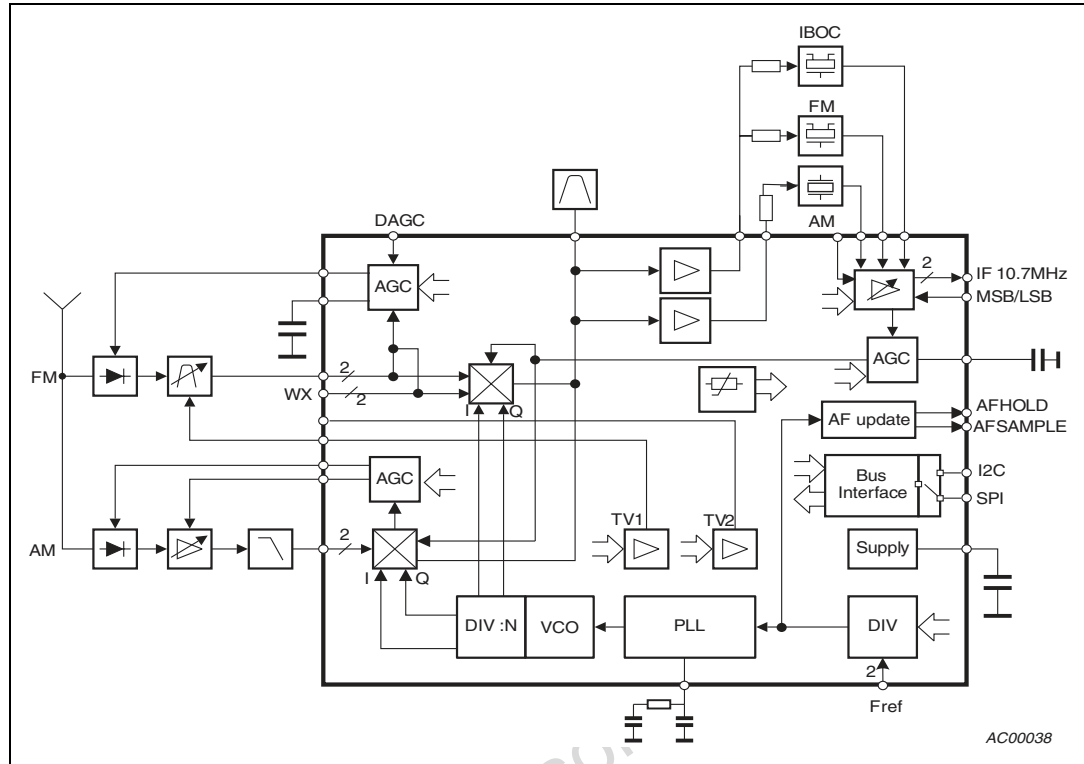

Obsolete Product(s) - Obsolete



## 2 Pin description

Figure 2. Pin connection

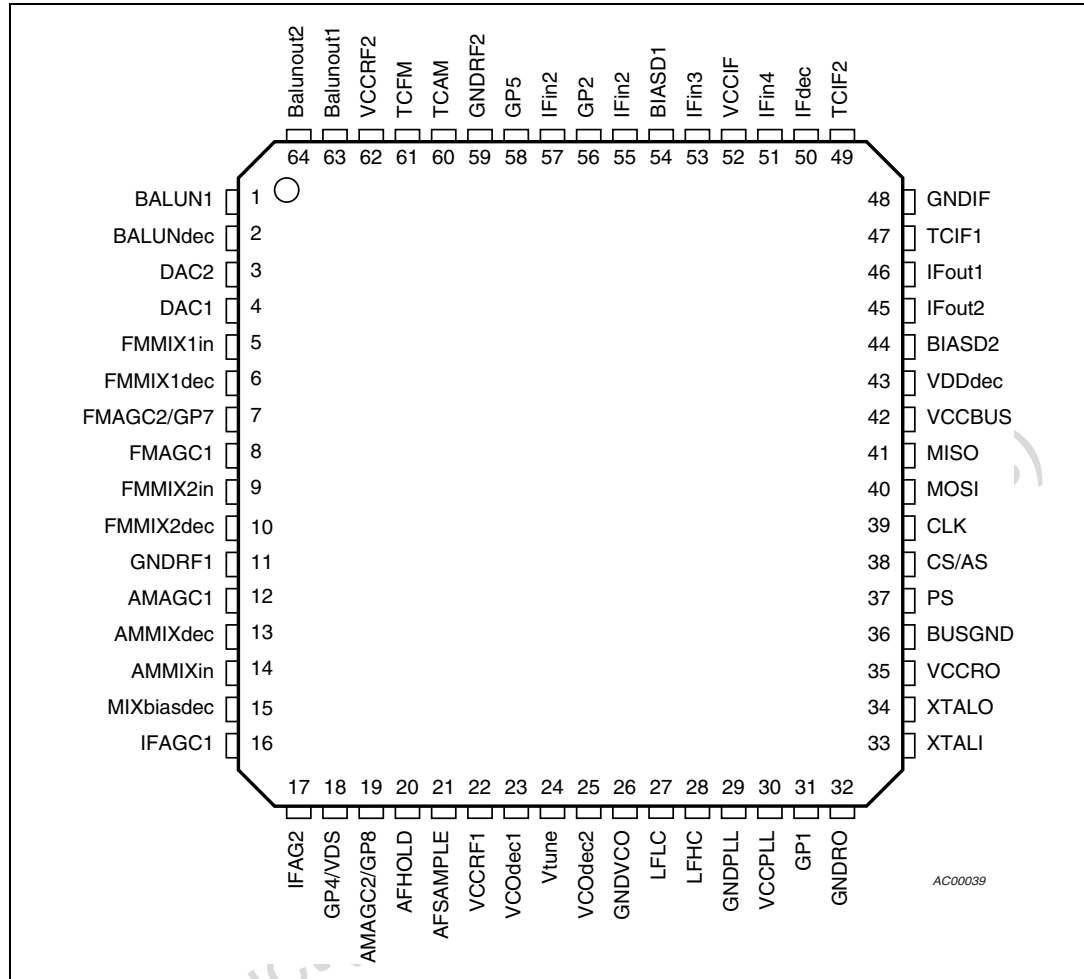

Table 2. Pin assignment

Pin #	Pin Name	Description
1	BALUN1	Active balun input 1
2	BALUNdec	Active balun input 2 (de coupling)
3	DAC2	Tuning DAC 2 output
4	DAC1	Tuning DAC 1 output
5	FMMIX1in	FM mixer input – high gain stage = mode 1
6	FMMIX1dec	FM mixer de couple
7	FMAGC2/GP7	FM AGC voltage output / alternative GP7 output
8	FMAGC1	FM PIN diode driver output
9	FMMIX2in	FM Mixer input – low gain stage = mode2

Table 2. Pin assignment (continued)

Pin #	Pin Name	Description
10	FMMIX2dec	FM Mixer de couple
11	GNDRF1	GND RF1 section
12	AMAGC1	AMAGC PIN diode driver output
13	AMMIXdec	AM mixer de couple
14	AMMIXin	AM mixer input
15	MIXbiasdec	Mixer bias de couplng
16	IFAGC1	IFAMP gain control via IFAGC - LSB
17	IFAGC2	IFAMP gain control via IFAGC - MSB
18	GP4/VDS	GPIO 4 / VDS input
19	AMAGC2 / GP8	AMAGC voltage output / alternative GP8 output
20	AFHOLD	AF state machine hold output
21	AFSAMPLE	AF state machine sample output
22	VCCRF1	Supply RF1 section
23	VCOdec1	BIAS de couple for VCO
24	Vtune	VCO tuning voltage
25	VCOdec2	BIAS de couple for VCO
26	GNDVCO	VCO Ground
27	LFLC	Loop filter low current output
28	LFHC	Loop filter high current output
29	GNDPLL	PLL Ground
30	VCCPLL	Supply PLL
31	GP1	GPIO 1
32	GNDRO	Ground PLL digital part
33	XTALI	Reference oscillator input
34	XTALO	Reference oscillator output
35	VCCRO	Supply PLL digital part
36	BUSGND	BUSinterface Ground
37	PS	Protocol Select
38	CS/AS	Chip select / Address select
39	CLK	SPI / I2C clodk
40	MOSI	SPIdata input / I2C Data
41	MISO	SPI Data Output
42	VCCBUS	Supply of BUSinterface
43	VDDdec	De couple of internal 3.3V (=3,3V + Vbe)

**Table 2. Pin assignment (continued)**

Pin #	Pin Name	Description
44	BIASD2	De coupling for Biasing
45	IFout2	Differential IF output 2
46	IFout1	Differential IF output 1
47	TCIF1	time constant IF AGC for AM
48	GNDIF	ground IF section
49	TCIF2	time constant IF AGC for FM
50	IFdec	De couple of IF amplifier
51	IFin4	IF input 4
52	VCCIF	Supply IF section
53	IFin3	IF input 3
54	BIASD1	De coupling for Biasing
55	IFin2	IF input 2
56	GP2	GPIO 2
57	IFin1	IF input 1
58	GP5	GPIO 5
59	GNDRF2	GND RF2 section = active balun GND
60	TCAM	AM AGC time constant
61	TCFM	FM AGC time constant
62	VCCRF2	Supply voltage RF2 section
63	Balunout1	Active balun output 2 = FM output
64	Balunout2	Active balun output 1 = AM output

### 3 Function description

#### 3.1 IMR mixer and active balun output

The IMR mixer has two FM inputs (referred as mode 1 / mode 2) and one AM input selectable by software. The FM inputs differ by their gains, noise figures, IIP3 and maximum signal handling capability. The mode 1 FM input (with the higher gain, lower IIP3 and lower noise figure) is normally coupled with passive antenna input stages; the mode 2 FM input is normally used for input stages featuring an external preamplifier.

There are two single ended outputs of the IMR mixer: Balunout1 has a 4 dB higher gain than Balunout2. It is not recommended to use both outputs in parallel.

The Balun1 pin is the current mixer output over an internal resistor. The LC filter at Balun1 can be realized with a low cost SMD-coil ( $Q \sim 4$ ).

#### 3.2 FM RF-AGC

The FM AGC system is controlled by a peak detector, whose gain can be varied by the keyed AGC. The latter function is meant to be controlled by a D/A converter in the back-end part of the system.

The time constant of the FM RF-AGC is defined by an external capacitor connected to TCFM and programmable internal currents. The currents can be selected independently for AGC attack and decay. By this the ratio between the attack and the decay time can be programmed between 0.4 and 250.

The FM RF-AGC has two output pins to drive one PIN diode attenuator and the external preamplifier gain control.

The AGC outputs can be programmed to the following modes:

1. Positive current  $I=f(e)$ : after reaching the AGC threshold voltage, the current output delivers a current  $I=f(e)$  up to 15mA in a voltage range from 0.1V (@10 $\mu$ A sink current) up to  $V_{CC}-1.2V$  with a quasi-exponential characteristic referred to the voltage at TCFM.

**Figure 3. Positive current diagram**

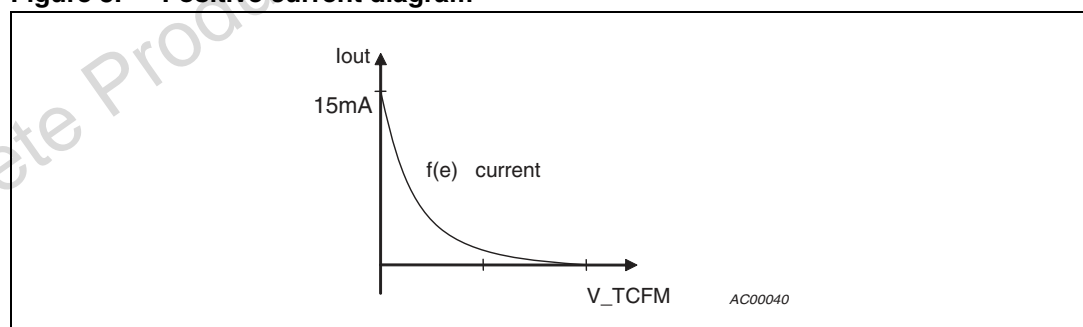

2. Pos/neg current  $I = f(e)$ : below the AGC threshold voltage the AGC output sinks a constant current of -5 mA. When the RF input level crosses the AGC threshold voltage, the current is reduced down to 0 mA with a quasi-logarithmic behavior. At half control voltage the current becomes positive and reaches up to 15mA following an exponential function.

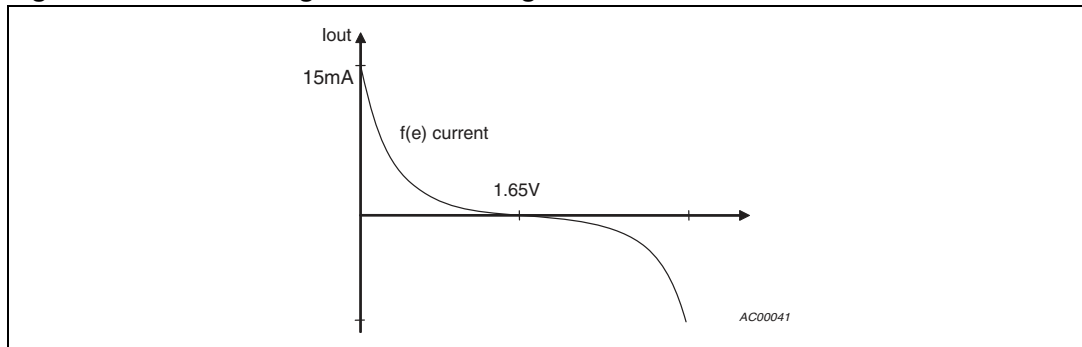
**Figure 4. Positive/negative current diagram**

3. Constant current mode: the output current can be set to 2 mA source current. The AGC detector is in power -down mode and only the PIN diode driver is active.
4. Voltage and current mode with hand-over: the  $V_{thr}$  level is programmable with 6 bit in the range of 0.2V to 2.56V. The voltage  $V_{thr}$  is the internal reference voltage of an external cascode transistor emitter feedback loop.

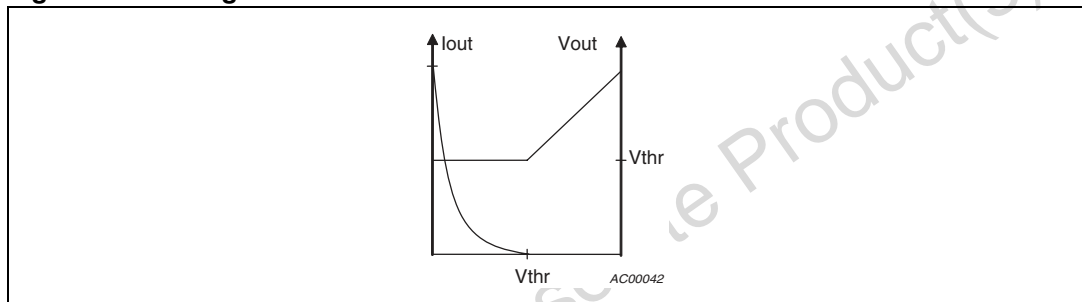
**Figure 5. Voltage and current mode with hand-over**

The voltage output swing is comprised between 0V and 3.3V (VDD).

The microcontroller can read the voltage at the AGC capacitor via the serial control interface.

### 3.3 AM RF-AGC

The AM AGC system is controlled by an average detector. The time constant of the AM RF-AGC is defined by an external capacitor connected to TCAM and programmable internal currents with symmetrical attack/decay behavior.

The AM RF-AGC has two output pins to drive one PIN diode attenuator and the external preamplifier gain control.

The AGC outputs can be programmed to the same modes as the FM RF-AGC with the exception of pos/neg current.

The microcontroller can read the voltage at the AGC capacitor via the serial control interface.

### 3.4 IF AGC and IF amplifier

The IF AGC system is controlled in AM with an average detector and in FM with a peak detector, and reduces the mixer gain. The time constant is defined by two external capacitors connected to TCIF1 and TCIF2 respectively, and programmable internal currents.

The microcontroller can read the voltage at the AGC capacitors via the serial control interface.

The IF amplifier gain is not affected by the on-chip IF-AGC but is meant to be controlled by the back-end part of the system through pins IFAGC1 and IFAGC2. The gain is reduced in 6 dB steps starting from the programmed value "G" according to the following table:

**Table 3. IF AGC and IF amplifier**

IFAGC2	IFAGC1	Gain
0	0	G
0	1	G - 6 dB
1	1	G - 12 dB
1	0	G - 18 dB

### 3.5 Dividers

The mixer divider V is followed by a divide-by-4-stage that generates 0°/90°/-90° LO signals for the IMR mixer (90°/-90° mode to switch between upper or lower side-band suppression in the IMR mixer).

The main divider N can be operated in integer mode.

### 3.6 D/A converters

The front-end contains two D/A-converters for tuning the filters of the FM pre-stage. The converters have a resolution of 9 bit.

### 3.7 VCO

The 3.7 GHz VCO has an internal switch that allows extending the oscillation frequency range. This is required by the fact that each of the two resulting VCO sub-bands (upper/lower) cannot individually cover the complete required frequency range versus temperature and process; for this reason a calibration procedure is needed to determine the process type (typical, slow, fast) and select the transition frequency between the two VCO sub-bands.

To run the procedure the VCO range 2 must be selected, the synthesized frequency needs to be set to 4GHz; then if  $V_{\text{tuning}} > 2.6\text{V}$  then the process is 'slow', if  $V_{\text{tuning}} < 1.7\text{V}$  then is 'fast' and otherwise is 'typical'. The switching frequency as a function of the process is reported in the following table:

**Table 4. Switching frequency as a function of the process**

Slow	Typ.	Fast
3.635 GHz	3.72 GHz	3.794 GHz

### 3.8 FREF

The reference frequency for the PLL can be derived by a XTAL directly connected to the device or by means of an LVDS signal. In the latter case an external matching resistor must be used to obtain the desired input signal level.

### 3.9 A/D converter

The front-end contains a 6 bit SAR A/D-converter for sensing several analog values of the tuner. The following analog sources can be switched to the ADC input by software command:

- FM RF AGC capacitor voltage
- AM RF AGC capacitor voltage
- IF AGC capacitor voltage (automatically connected to the FM or AM IF AGC filtering capacitor)
- PLL tuning voltage
- Temperature sensor
- GPIO 1 voltage
- GPIO 2 voltage
- ADC reference generated from VCC.

The ADC can be clocked by an integrated RC-oscillator, in which case the oscillation frequency is programmable, or by the PLL reference frequency.

### 3.10 GPIO - general purpose IO interface pins

The front-end has seven GPIO - general purpose control pins to switch external stages (output), e.g. amplifiers, or to read the status of external stages (input), e.g. control voltages. Some control pins are multiplexed with other functions that are not necessary in every tuner design (FM AGC keying, AM cascode control). All the GPIOs may put in tristate or in enable mode. When in enable the GPIOs can be configured as shown in the following table.

All GPIOs are short-circuit protected by current limiter and voltage-tolerant up to 3.5 V.

**Table 5. GPIO - general purpose IO interface pins**

GPIO ports	Function	Note
GPIO1	Selects function of GPIO1: if input, connects GPIO1 to ADC (ADC must then be configured to use GPIO1 as input); if output, level depends on GPIO Out Lev Ctrl → GPIO1	– AnlIn to AD – DigOut
GPIO2	Selects function of GPIO2: if input, connects GPIO2 to ADC (ADC must then be configured to use GPIO2 as input) and to KAGC (FM KAGC must then be enabled); if output, level depends on GPIO Out Lev Ctr → GPIO2	– AnlIn to AD – Kagc In – DigOut
GPIO4	Selects function of GPIO4: if input, configures GPIO4 as AM Cascode $V_{DS}$ input; if output, level depends on GPIO Out Lev Ctrl → GPIO4	– AnlIn – DigOut
GPIO5	Selects function of GPIO5: if input, it is directly connected to read-only register byte 48 bit 4; if output, level depends on GPIO Out Lev Ctrl → GPIO5. When set to input, it is necessary to set IF AMP → GPIO5 out mode to “ON GPIO5 out En” (labels are wrong). Also used for production testing as analog output (not relevant for application).	– DigIn – Out (Dig or Anl)
GPIO6	Selects function of GPIO6 if device is configured in I <sup>2</sup> C mode: if input, it is directly connected to read-only register byte 48 bit 5; if output, level depends on GPIO Out Lev Ctrl → GPIO5. When the device is configured in SPI mode, program GPIO Out Lev Ctr → GPIO5 to “Low”. The value of GPIO mode → GPIO5 does not matter	– Din (spi MISO out) – Dout (spi MISO out)
GPIO7	Selects function of GPIO7: if digital output is selected, level depends on GPIO Out Lev Ctrl → GPIO7; otherwise, configures GPIO7 as FM AGC Vout	– Digital Out – FM agc Vout
GPIO8	Selects function of GPIO8: if output, level depends on GPIO Out Lev Ctrl → GPIO8; otherwise, configures GPIO8 as AM AGC Vout	– Digital Out – AM agc Vout



### 3.11 AFSAMPLE/AFHOLD

On the TDA7529 there are two dedicated open drain pins (AFSAMPLE and AFHOLD), that allow the control of the DSP (mute and quality controls) during AF update.

Details are given in [Chapter 5](#).

### 3.12 Serial bus interface

The TDA7529 has a serial data port for communication with the microcontroller. It is used for programming the device and for reading out its detectors. This port supports data communication using the SPI and the I<sup>2</sup>C protocol. The data transfer of several consecutive bytes is supported by the auto increment feature.

**Table 6. Supports data communication using the SPI and the I<sup>2</sup>C protocol**

Name	Pin	SPI signal	Pin	I <sup>2</sup> C signal
Signal 1	PS	Protocol Select SPI/I <sup>2</sup> C	PS	Protocol Select SPI/I <sup>2</sup> C
Signal 2	CS	Chip Select	AS	Address Select
Signal 3	CLK	Clock	CLK	Clock
Signal 4	MOSI	Master Out – Slave In	DATA	bidirectional Data
Signal 5	MISO	Master In – Slave Out	GP6	General Purpose Out

The "PS"- pin (protocol select) determines which communication protocol is used. The information is not latched, so any level change at this pin immediately affects the protocol used by the TDA7529.

The SPI protocol is selected by setting PS = 0 while, during the I<sup>2</sup>C operation, PS needs to be open (internally set to 1).

SPI-Protocol: CPOL=1, CPHA=1.

The CS pin performs the Chip Select function during the SPI operation; it has to be reset to 0 during transmission or reception, otherwise set to 1 (the CS pin is set to 1 by leaving it open).

Both the CS and the AS functions are performed by the CS pin.

When the I<sup>2</sup>C mode is used, the "AS" pin determines which I<sup>2</sup>C address or group of addresses (see below) is used. Three different external connections are defined to represent three groups of addresses (refer to the following table for details). The information is not latched, so any level change at this pin immediately affects the address used by the TDA7529.

First the IC address is transmitted including the R/W bit for setting the direction of the following data transfer

**Table 7. I<sup>2</sup>C addresses**

Tuner:	Tuner 3	Tuner 2	Tuner 1
level at pin AS	2.2V – 3.5V	1.1V – 1.7V	0.0V – 0.6V
address:	1100 1xxd	1100 x1xd	1100 xx1d
<b>MSB ... LSB</b>	-	-	-
1100 000d	-	-	-
1100 001d	-	-	R / W
1100 010d	-	R / W	-
1100 011d	-	W	W
1100 100d	R / W	-	-
1100 101d	W	-	W
1100 110d	W	W	-
1100 111d	W	W	W

- x = must be "0" for reading, can be "1" or "0" for writing to the TDA7529
- d = determinates the direction of data transfer, reading or writing
- R / W = indicates the address to read to and/or to write from a single TDA7529
- W = indicates those addresses that can be used to transmit equal data to several TDA7529 frontends. A read out has no purpose for these addresses (data collision), but must be possible without damaging the tuner IC.

The two serial bus protocols, I<sup>2</sup>C and SPI, are as follows:

**Figure 6. I<sup>2</sup>C (sub address mode)**

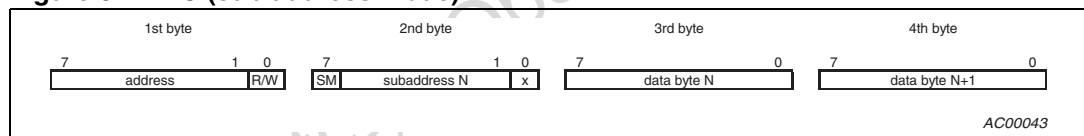

**Figure 7. SPI**

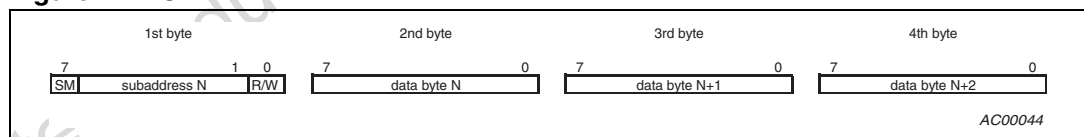

Data auto increment mode is always active regardless of the serial bus mode chosen.

## 4 Electrical specifications

Electrical parameters are guaranteed if  $F_{ref} = 100\text{kHz}$ , with frequency stability of  $\pm 20\text{ppm}$  max.

### 4.1 Absolute maximum ratings

Table 8. Absolute maximum ratings

Symbol	Parameter	Test condition	Min	Typ	Max	Units
$V_{CC}$	Abs. supply voltage	-	-	-	5.5	V
$T_{amb}$	Ambient temperature range	-	-40	-	105	°C
$T_{stg}$	Storage temperature	-	-55	-	150	°C
$T_j$	Junction temperature	-	-	-	150	°C

### 4.2 Thermal data

Table 9. Thermal data

Symbol	Parameter	Test condition, comments	Min	Typ	Max	Units
$R_{thj-amb}$	Thermal resistance junction to ambient	2s2p std Jedec board with thermal via underneath the component (36 board via: diameter = 0.5mm / pitch = 1.5mm), max 30% missing soldering	-	-	33	°C/W

### 4.3 General key parameters

Table 10. General key parameters

Symbol	Parameter	Test Condition, Comments	Min	Typ	Max	Units
$V_{CC}$	5V supply voltage	-	4.7	5	5.35	V
$I_{CC}$	Supply current @ 5V	-	-	145	175	mA
$I_{CC\_pwd}$	Supply current @ 5V in power down mode	-	-	9	14	mA
$T_{amb}$	Ambient temperature range	-	-40	-	105	°C

## 4.4 FM - section

Refer to application circuit in figure 3.  $V_{CC} = 4.7V$  to  $5.35V$ ;  $T_{amb} = -40$  to  $+105^{\circ}C$ ;  $f_c = 76$  to  $108$  MHz;  $60dB\mu V$  antenna level; mono signal, unless otherwise specified. Antenna level equivalence:  $0dB\mu V = 1\mu V_{rms}$ , all RF levels are intended as PD.

**Table 11. FM - section**

Symbol	Parameter	Test condition, comments	Min	Typ	Max	Units
<b>FM IMR Mixer and active balun</b>						
$G_{mix1}$	Mixer conversion gain	mode 1 (unloaded)	20	22	24	dB
		mode 2 (unloaded)	14	16	18	
-	Gain attenuation range	controlled by IF-AGC	18	20	-	dB
$R_{in}$	Input impedance	mode 1	30	50	-	$k\Omega$
		mode 2	5	6.5	9.5	
$R_{out}$	Output impedance	active balun	15	20	30	$\Omega$
$V_{out\_max}$	Max. output voltage	without clipping (unloaded)	122	-	-	$dB\mu V$
$V_{noise}$	Input noise voltage	Mode1, Rsource=1.5k $\Omega$ , noiseless	-	3	3.7	$nV/\sqrt{Hz}$
		Mode 2, Rsource=800, noiseless	-	5	6	
IIP3	3 <sup>rd</sup> order intercept point <sup>(1)</sup>	mode 1 up to $V_{in}/tone = 90$ $dB\mu V$	123	125	-	$dB\mu V$
		mode 2 up to $V_{in}/tone = 98$ $dB\mu V$	132	134	-	
IIP2	2 <sup>nd</sup> order intercept point	mode 1	144	-	-	$dB\mu V$
		mode 2	152	-	-	
IRR	Image rejection ratio	without gain/phase adjust	30	-	-	dB
		with gain/phase adjust	40	45	-	
<b>FM RF AGC</b>						
$L_{thr}$	Mixer input referred RF level threshold	mode 1, min. setting	82	85	88	$dB\mu V$
		mode 1, max setting	97	100	103	
		mode 2, min. setting	90	93	96	
		mode 2, max setting	105	108	111	
-	Threshold steps	4 bit control	0.5	1	1.5	dB
-	Pin diode source current	AGC control pin 1 Logarithmic current	10	-	-	mA
-	Pin diode sink current	AGC control pin 1 Logarithmic current	-	-	-3	mA
-	Pin diode source current in constant current mode	-	1	2	-	mA
-	Threshold shift keyed AGC	Control input = 1V	10.5	12.5	13.5	$dB/V$

1. parameter guaranteed by correlation.

## 4.5 AM - section

Refer to application circuit in figure 3.  $V_{CC} = 4.7V$  to  $5.35V$ ;  $T_{amb} = -40$  to  $+105^{\circ}C$ ; LW, MW and SW bands;  $74dB\mu V$  antenna level, unless otherwise specified. Antenna level equivalence:  $0dB\mu V = 1\mu V_{rms}$ , all RF levels are intended as EMF.

**Table 12. AM - section**

Symbol	Parameter	Test condition, comments	Min	Typ	Max	Units
<b>AM IMR Mixer and active balun</b>						
Gmix1	Mixer conversion gain	-	7.2	9	10.5	dB
$\Delta g_{mix1}$	Gain attenuation range	controlled by IF-AGC	18	20	-	dB
Rin	Input impedance	-	5	6.5	9.5	$k\Omega$
Rout	Output impedance	-	15	20	30	$\Omega$
-	Min. external load	-	400	-	-	$\Omega$
Vin_max	Max. output voltage	without clipping (unloaded)	122	-	-	$dB\mu V$
Vnoise	Input noise voltage	-	-	6	8.3	$nV/\sqrt{Hz}$
IIP3	3 <sup>rd</sup> order intercept point	-	130	134	-	$dB\mu V$
IIP2	2 <sup>nd</sup> order intercept point	-	159	-	-	$dB\mu V$
IRR	Image rejection ratio	without gain/phase adjust	30	-	-	dB
IRR	Image rejection ratio	with gain/phase adjust	40	45	-	dB
<b>AM RF AGC</b>						
External capacitance for time constant from 1nF to 4700nF – time constant values are directly proportional to the external capacitor value						
Lthr	Mixer input referred RF level threshold	min. setting	83	86	89	$dB\mu V$
		max setting	98	101	104	
-	threshold steps	4 bit control	0.5	1	1.5	dB
-	Pin diode source current	AGC control pin 1 Logarithmic current	10	-	-	mA
-	Min. voltage	AGC control pin 1 with $5\mu A$ sink current	-	-	0.1	V
-	Isink	$5\mu A$ sink current	5	10	-	$\mu A$
-	Pin diode source current in constant current mode	-	1	-	-	mA
-	Max. voltage	AGC control pin 1	$V_{CC}-1.4$	$V_{CC}-1.2$	-	V
-	Max. output voltage in GPO mode	AGC control pin 2	$V_{DD}-0.3$	-	$V_{DD}$	V
-	Min. output voltage	AGC control pin 2	-	-	0.3	V

Table 12. AM - section (continued)

Symbol	Parameter	Test condition, comments	Min	Typ	Max	Units
-	Fast attack time constant	active in case of overdrive (more than 7dB)	0.05	0.5	5	ms
-	Time constant	Range, mode T1 Range, mode T2 Range, mode T3	-	0.5-50 2.5-250 12.5-1250	-	ms ms ms

## 4.6 IF - section

Table 13. IF - section

Symbol	Parameter	Test condition, comments	Min	Typ	Max	Units
<b>IF AMPLIFIER</b>						
Grange	Gain range	Input 1-3 (FM,HD,AM), min.	23	25	27	dB
		Input 1-3 (FM,HD,AM), max	36	38	40	
		Input 4 (HD-Radio AM), min.	15	17	19	
		Input 4 (HD-Radio AM), max	29	31	33	
Gstep	Gain step	3 bit control	1.5	2	2.5	dB
$\Delta$ AGC	AGC range	-	16.5	18	19	dB
	AGC steps	2-bit control	5.2	6	6.6	
Rin_input1	Input impedance input 1	FM -input @ 10.7MHz	230	330	450	$\Omega$
Rin_input2	Input impedance input 2	HD-Radio FM input @ 10.7MHz	2.2	2.9	3.6	k $\Omega$
Rin_input3	Input impedance input 3	AM input @ 10.7MHz	7	8.2	10	k $\Omega$
Rin_input4	Input impedance input 4	HD-Radio AM input @ 10.7MHz	7	8.7	11	k $\Omega$
Rout	Differential output impedance	-	-	15	-	$\Omega$
Vout_max	Max. output voltage	-	115	-	117	d $\mu$ V
Gain, load	Gain variation in loaded conditions	10pF between each IFAMP outputs and GND, 10k $\Omega$ differential load	-	-	0.5	dB
IIP3,load	IIP3 decrease in loaded conditions	10pF between each IFAMP outputs and GND, 10k $\Omega$ differential load	-	-	1	dB
IIP3	3 <sup>rd</sup> order intercept point	input stage 1-3, @ 25dB gain	119	122	-	d $\mu$ V
		input stage 4, @ 17dB gain	130	133	-	
IIP2	2 <sup>nd</sup> order intercept point	input stage 1-3	142	-	-	d $\mu$ V
		input stage 4	154	-	-	

Table 13. IF - section (continued)

Symbol	Parameter	Test condition, comments	Min	Typ	Max	Units
Vnoise_input 1	IN1 input noise voltage	@ source impedance 330Ω · noiseless, @31dB gain	-	3.5	4.2	nV/√Hz
Vnoise_input 2	IN2 input noise voltage	@ source impedance 470Ω · noiseless, @ 31dB gain, with external 560Ω input termination resistor	-	3.8	4.6	nV/√Hz
Vnoise_input 3	IN3 input noise voltage	@ source impedance 2.2kΩ · noiseless, @ 29dB gain, with external 2.7kΩ input termination resistor	-	5	6.5	nV/√Hz
Vnoise_input 4	IN4 input noise voltage	@ source impedance 2.2kΩ · noiseless, @ 24dB gain, with external 2.7kΩ input termination resistor	-	7	8.5	nV/√Hz
<b>IF AGC</b>						
External capacitance for time constant from 10nF to 500nF in FM (asym. mode), from 100nF to 4700nF in AM (sym. mode) – time constant values are directly proportional to the external capacitor value						
Lthr	IFamp input referred	FM, min. setting	88.5	91	93.5	dBμV
		FM, max setting	99.5	101	103.5	
		AM, min. setting	86.5	89	91.5	
		AM, max setting	96.5	99	101.5	
-	Threshold steps	-	1	1.5	2	dB
-	Fast attack mode in AM-mode, range	active in case of overdrive	0.05	0.5	5	ms
-	Time constant attack, range	FM: asym. mode U1 FM: asym. mode U2 AM: sym. mode S1 AM: sym. mode S2	-	10-500 0.05-2.5 2.0-100 20-1000	-	μs ms ms ms
-	Time constant decay, range	FM: asym. mode U1 / U2 AM: sym. mode S1 AM: sym. mode S2	-	2-100 2-100 20-1000	-	ms ms ms

## 4.7 VCO

Table 14. VCO

Symbol	Parameter	Test condition, comments	Min	Typ	Max	Units
-	Frequency range VCO	±8% tuning range	3430		4010	MHz
-	Phase Noise of LO	Free running VCO; values referred @ 100MHz @ 10 Hz @ 100 Hz @ 1 kHz @ 10 kHz	-46 -76 -103	-40 -60 -86 -106	-	dBc/Hz
-	Deviation error	FM reception, de-emphasis 50µs, fNF=20Hz...20kHz @ min. VCO frequency	-	8	-	Hz

## 4.8 Reference frequency input buffer

Table 15. Reference frequency input buffer

Symbol	Parameter	Test condition, comments	Min	Typ	Max	Units
<b>Reference frequency input buffer mode</b>						
-	Max input voltage high	-	-	-	1475	mV
-	Min. input voltage low	-	925	-	-	mV
-	Input differential voltage	-	200	-	400	mV
-	Input impedance (xtal mode)	-	150	-	-	kΩ
-	Input impedance (lvds mode)	-	10	-	-	kΩ
-	Input voltage range	Single ended mode	200	-	1000	mV <sub>PP</sub>

## 4.9 Dividers

Table 16. Dividers

Symbol	Parameter	Test condition, comments	Min	Typ	Max	Units
<b>Mixer divider V – integer values</b>						
N <sub>V</sub>	divider value divider_V	7 bit	5	-	131	-
<b>Divide by 4 – generation of 0°/90°/-90° LO signal for IMR</b>						
-	I/Q phase error of divider	phase calibration in IMR	-0.5	-	0.5	DEG
<b>Main divider N – integer divider</b>						
N <sub>N</sub>	divider value divider_N	21bit (32/33 pre scaler)	992	-	2097151	-
<b>Reference divider R – integer values</b>						
N <sub>R</sub>	divider value divider_R	8 bit	1	-	255	-



## 4.10 Phase locked loop

Table 17. Phase Locked Loop

Symbol	Parameter	Test Condition, Comments	Min	Typ	Max	Units
-	Settling time AM/FM	$\Delta f < 0,01\%$ @ $f_{PFD} = 100$ kHz	-	800	1200	$\mu s$
-	Spurious suppression	@ divided VCO signal	70	-	-	dB

## 4.11 Phase frequency detector and charge pump

Table 18. Phase frequency detector and charge pump

Symbol	Parameter	Test Condition, Comments	Min	Typ	Max	Units
<b>PFD</b>						
$f_{PFD}$	PFD input frequency	-	2	-	3000	kHz
<b>Charge pump</b>						
-	Sink current	high current mode bit1	-0.4	-0.65	-0.9	mA
		high current mode bit2	-0.8	-1.3	-1.7	mA
		high current mode bit3	-1.7	-2.4	-3.1	mA
		high current mode bit4	-3.1	-4.5	-5.8	mA
		low current mode bit5	-40	-60	-80	$\mu A$
		low current mode bit6	-80	-120	-160	$\mu A$
		low current mode bit7	-160	-240	-320	$\mu A$
		low current mode bit8	-320	-480	-640	$\mu A$
		low current mode bit9	-640	-960	-1280	$\mu A$
-	Source current	high current mode bit1	0.4	0.65	0.9	mA
		high current mode bit2	0.8	1.3	1.7	mA
		high current mode bit3	1.7	2.4	3.1	mA
		high current mode bit4	3.1	4.5	5.8	mA
		low current mode bit5	40	60	80	$\mu A$
		low current mode bit6	80	120	160	$\mu A$
		low current mode bit7	160	240	320	$\mu A$
		low current mode bit8	320	480	640	$\mu A$
		low current mode bit9	640	960	1280	$\mu A$

## 4.12 Temperature sensor

Table 19. Temperature sensor

Symbol	Parameter	Test condition, comments	Min	Typ	Max	Units
-	Temperature range	-	-40		150	°C
-	Resolution	°C/LSB (no direct measurement possible)	-	5	-	°C
-	Absolute error	-	-	-	15	°C
-	Relative error	-	-	0.5	-	LSB

## 4.13 D/A-converter

Table 20. D/A-converter

Symbol	Parameter	Test condition, comments	Min	Typ	Max	Units
$V_{out}$	Output voltage minimum value	Unloaded output	0.5	0.6	0.8	V
	Output voltage maximum value	Unloaded output	$V_{CC} - 0.2$	$V_{CC} - 0.1$	-	V
-	Output impedance	-	-	2	-	k $\Omega$
-	Max. output current	-	500	-	-	$\mu$ A
-	Average Voltage step	resolution 9bit	8.5	9	9.5	mV
-	INL	-	-2	-	2	LSB
-	DNL	-	-0.5	-	0.5	LSB
-	Conversion time	@ $C_L=1nF$	-	20	40	$\mu$ s
VSRR	Supply voltage ripple rejection ratio	-	20	-	-	dB

## 4.14 A/D-converter

Table 21. A/D-converter

Symbol	Parameter	Test condition, comments	Min	Typ	Max	Units
-	INL	-	-2	-	2	LSB
-	DNL	-	-0.5	-	0.5	LSB
-	Input voltage range	-	0	-	$V_{DD}$	V
$t_{ADC}$	Conversion time	-	-	-	7	$\mu$ s

## 4.15 GPIO – general purpose IO interface pins

Table 22. GPIO - general purpose IO interface pins

Pin name	GPIO functionality						Multiplexed functionality details are given in the corresponding chapters
	GPIO-Output				GPIO-Input		
	High level		Low level		Functionality	Voltage	
	Voltage	Source current	Voltage	Sink current			
GP1	3.3V	1 mA	0V	1 mA	Analog input ADC	0 ... 3.3V	
GP2	3.3V	1 mA	0V	1 mA	Analog input ADC	0 ... 3.3V	FM key AGC input
GP4	3.3V	0.1 mA	0V	10 mA	AM cascode $V_{DS}$ input	0 ... 3.3V	
GP5	3.3V	1 mA	0V	1 mA	Digital Input	0 / 3.3V	
GP6	3.3V	1 mA	0V	1 mA	Digital Input	0 / 3.3V	SPI MISO output
GP7	3.3V	1 mA	0V	1 mA	-	-	FM-AGC voltage output
GP8	3.3V	1 mA	0V	1 mA	-	-	AM-AGC voltage output

Symbol	Parameter	Test Condition	Min	Typ	Max	Units
-	High level output voltage	@ 100k $\Omega$ load to GND	$V_{DD}-0.3$	-	-	V
-	Low level output voltage	@ 100k $\Omega$ load to $V_{DD}$	-	-	0.3	V
-	High level source current	GP1 / GP2 / GP5 / GP6: @ 1k $\Omega$ load to GND	0.5	1	-	mA
-	High level source current	GP4 @ 1k $\Omega$ load to GND	0.08	0.1	-	mA
-	low level sink current	GP1 / GP2 / GP5 / GP6: @ 1k $\Omega$ load to $V_{DD}$	0.8	1	-	mA
-	low level sink current	GP4: @ 100 $\Omega$ load to $V_{DD}$	8.0	10	-	mA
-	Input impedance	digital input mode	100	-	-	k $\Omega$
-	Input voltage range	GP1 / GP2	0	-	3.5	V
-	High level input voltage	GP5 / GP6 used as digital input	2.2	-	3.5	V
-	Low level input voltage	GP5 / GP6 used as digital input	-0.05	-	1.0	V

## 4.16 AFSAMPLE / AFHOLD

Table 23. AFSAMPLE / AFHOLD

Symbol	Parameter	Test Condition, Comments	Min	Typ	Max	Units
-	Output voltage at AFSAMPLE/AFHOLD	-	-	-	3.6	V
-	Maximum sink current	$V_o = 0.4V$	800	-	-	$\mu A$

## 4.17 Serial data interface

**Table 24. Serial data interface**

Symbol	Parameter	Test condition, comments	Min	Typ	Max	Units
VDD	Supply voltage	-	2.7	-	3.5	V
f <sub>clk</sub>	Clock frequency	Guaranteed range @ SPI Guaranteed range @ I <sup>2</sup> C	4 1	-	-	MHz MHz
-	Power On Delay time	Ready for communication after Power-On-Reset	-	-	10	ms
-	High level output voltage	Output signals	V <sub>DD</sub> -0.3	-	V <sub>DD</sub>	V
-	Low level output voltage	Output signals	-0.05	-	0.3	V
-	High level source current	Output signals	0.08	0.1	-	mA
-	low level sink current	Output signals	0.8	1	-	mA
-	Rise / fall time	Output signals, 90%	15	25	40	ns
-	High level input voltage	Input signals, except AS	2.3	-	3.5	V
-	Low level input voltage	Input signals, except AS	-0.05	-	1.0	V
-	High level input voltage	AS input signal	2.2	-	3.5	V
-	Medium level input voltage	AS input signal	1.1	-	1.7	V
-	Low level input voltage	AS input signal	-0.05	-	0.6	V
-	Input impedance	Input signals	100	-	-	kΩ
-	Power-On impedance	All signals	100	-	-	kΩ
-	Rise / fall time	Input signals except CLK, min. acceptable duration range, 90%	0.01	-	1000	μs
-		Input signal CLK, min. acceptable duration range, 90%	0.01	-	10	μs

## 5 Tuning state machine

Frequency changes in a system employing the TDA7529 can be efficiently performed using a built-in state machine which simplifies the microprocessor supervisory functions. The state machine, which can work in 8 different modes, can be invoked by a simple WRITE operation into the tuner registers and, provided that the frequency to be jumped to has been pre-loaded into the front-end registers through a previous separate or is loaded through a concurrent WRITE operation, the FE jump sequence is automatically managed and flags are provided to the back-end to indicate the current condition.

### 5.1 Tuning state machine modes

Hereafter the description of the 8 modes can be found. They are chosen by Byte 12 bits<6:4>.

The diagrams depicting the FE and flag conditions for each of the 8 modes are as follows:

#### 5.1.1 Mode 000: buffer (nil)

When this mode is selected, no action is undertaken by the state machine.

#### 5.1.2 Mode 001: preset

**Figure 8. Preset timing diagram**

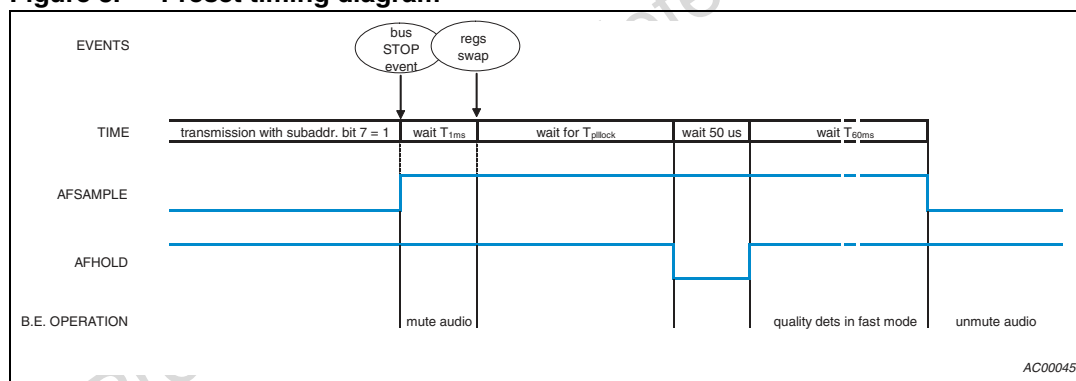

This mode is used to jump to a different frequency and stay there, with reception at the end of the sequence.

AFSAMPLE can be used to tell the back-end when to mute and to unmute the audio output. The 60 ms mute time (programmable) after the PLL has reached the locked condition can be used to check the RDS signal presence and content in addition to the analog quality information.

AFHOLD can be used to tell the back-end to switch to faster time constants for quick quality acquisition.

### 5.1.3 Mode 010: search

Figure 9. Search timing diagram

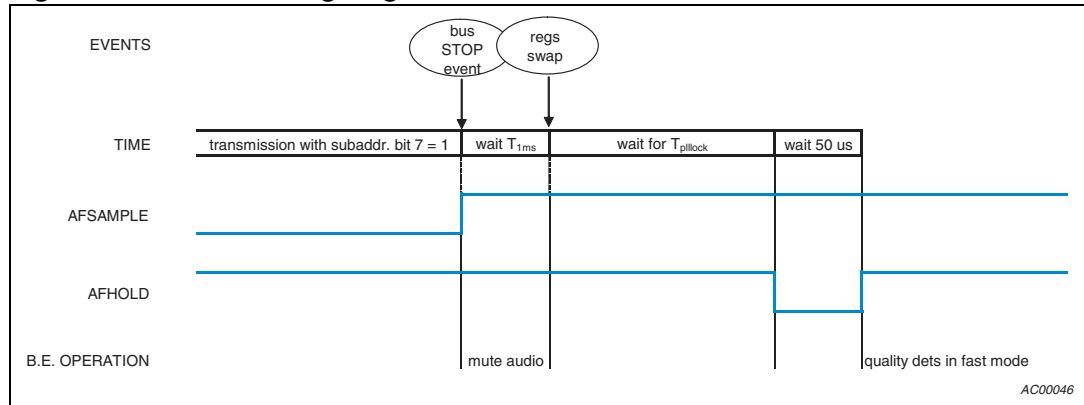

This mode is used to jump to a different frequency and stay there, with audio muted.

AFSAMPLE can be used to tell the back-end when to mute the audio output.

AFHOLD can be used to tell the back-end to switch to faster time constants for quick quality acquisition.

### 5.1.4 Mode 011: AF update

Figure 10. AF update timing diagram

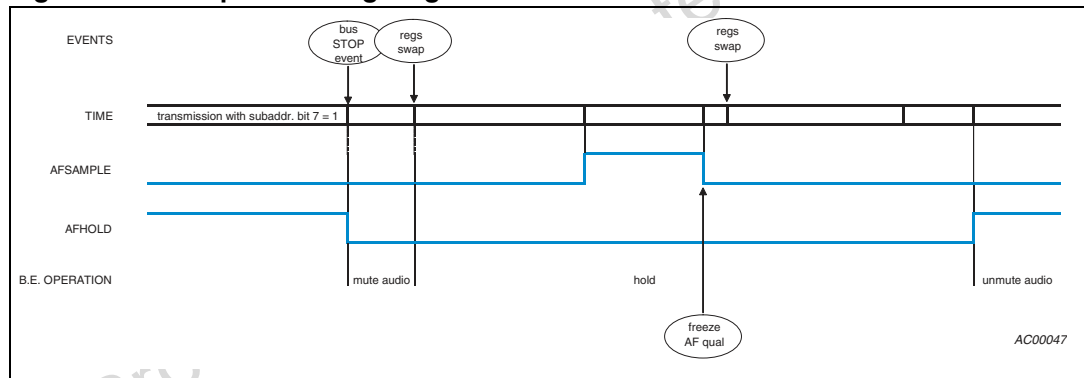

This mode is used to jump to an AF frequency, check its quality, jump back to the starting frequency and continue reception.

AFSAMPLE can be used to tell the back-end when to acquire the AF frequency quality.

AFHOLD can be used to tell the back-end to mute/unmute the audio and keep normal processing on hold.

### 5.1.5 Mode 100: jump

Figure 11. Jump timing diagram

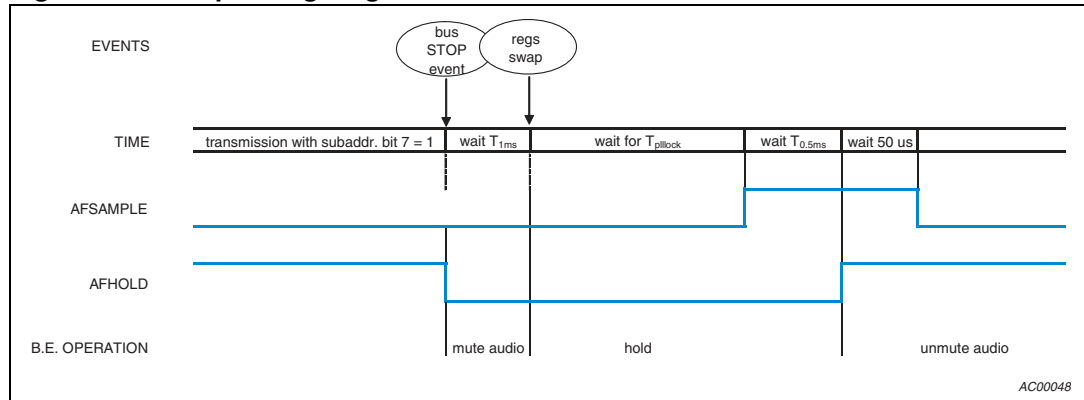

This mode is used to jump to a different frequency and stay there, with reception at the end of the sequence.

AFHOLD can be used to tell the back-end to mute/unmute the audio and keep normal processing on hold.

AFSAMPLE can be used to tell the back-end when the quality signal processing can be restarted, with a stable situation to start from.

### 5.2 Mode 100: check

Figure 12. Check timing diagram

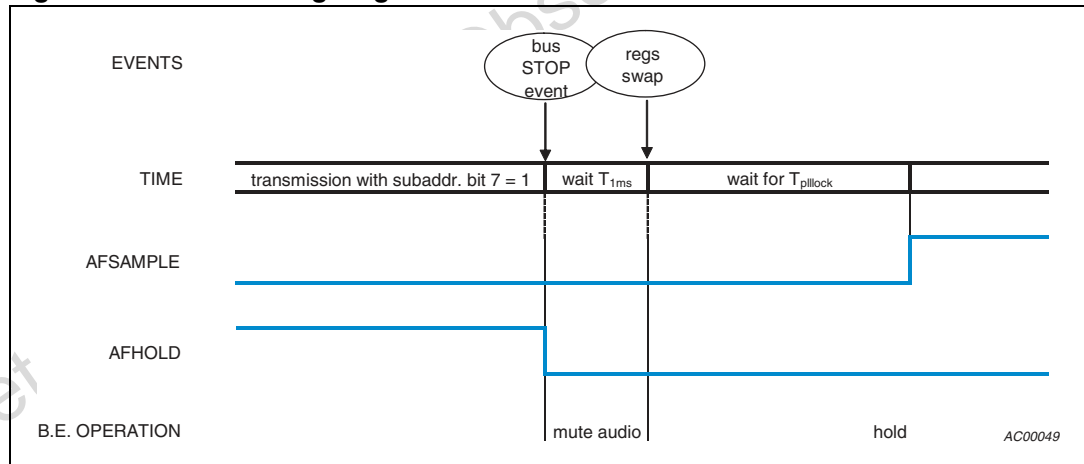

This mode is used to jump to a different frequency and stay there, with audio muted.

AFHOLD can be used to tell the back-end to mute/unmute the audio and keep normal processing on hold.

AFSAMPLE can be used to tell the back-end when to freeze the quality signal processing.

### 5.3 Mode 110: load

Figure 13. Load timing diagram

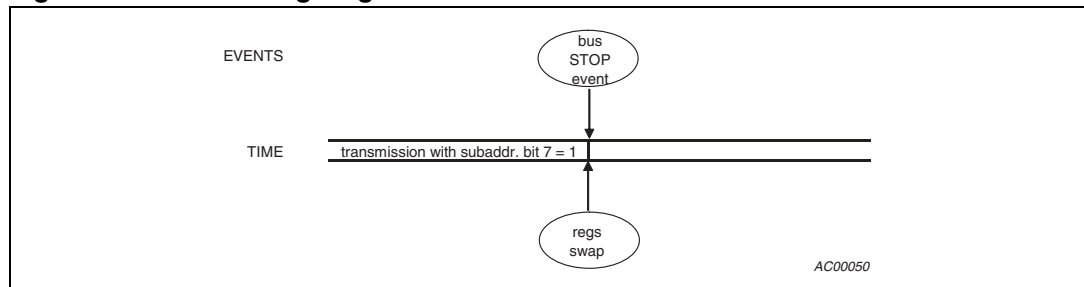

The content of the buffer and control registers is swapped. No transition occurs on the AFHOLD and AFSAMPLE lines.

### 5.4 Mode 111: end

Figure 14. End timing diagram

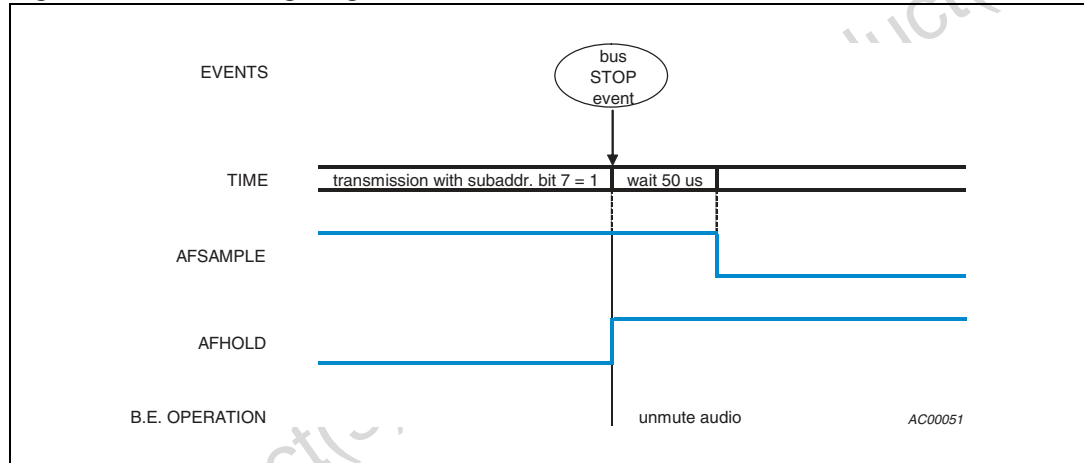

This mode is used to end sequences that terminate with muted audio, after the decision on whether to stay to that frequency or jump to a different one has been taken.

AFHOLD can be used to tell the back-end to unmute the audio.

AFSAMPLE can be used to tell the back-end to restore normal quality signal processing.

Most of the wait times of the algorithm can actually be programmed.

The following table summarizes the minimum, maximum and default values of the programmable wait times. The indicated values are valid only for the advised configuration where the phase detector reference frequency is 100 kHz.



Table 25. Values of the programmable wait times

PARAMETER NAME	REGISTER		VALUE	TIME
T <sub>plllock</sub>	Byte 15 bits<7:3>	min.	00000	20 us
		default	00110	1 ms
		maximum	11111	5 ms
T <sub>0.5ms</sub>	Byte 30 bits<7:2>	min.	000000	70 us
		default	000101	0.5 ms
		maximum	111111	5 ms
T <sub>1ms</sub>	Byte 20 bits<7:2>	min.	000000	10 us
		default	001100	1 ms
		maximum	111111	5 ms
T <sub>2ms</sub>	Byte 29 bits<7:2>	min.	000000	50 us
		default	011000	2 ms
		maximum	111111	5 ms
T <sub>60ms</sub>	Byte 04 bits<7:3>	min.	00000	1 ms
		default	10111	60 ms
		maximum	11111	80 ms

## 5.5 Register SWAP

Some of these modes contain one or two register "swap" operation(s). The changes within the register structure during a swap operation depend on the operating mode of the chip.

If the chip is programmed in the "buffer/control" mode (chosen by setting byte 12 bit 7 = 1), which is necessary to take advantage of the tuning state machine, it is suggested that the microprocessor write data only in the normal register bank (bytes from 16 to 31), because the state machine itself takes care of exchanging the content of the normal register bank with that of the shadow bank (bytes from 32 to 47) during a swap. The normal registers are intended to be written to by the radio microprocessor, whereas the registers that actually control the device circuits are the shadow ones.

In any case it is suggested that the bits 5 and 4 of byte 0, that define which control bank is actually used to drive the device circuits, should not be touched after setting them to 0 after reset because they are automatically updated by the tuning state machine.

### 5.6 State machine start

The tuning state machine is activated only at the end of the transmission if bit 7 of the subaddress is 1. The activation sequence, therefore, is to be done in the following way.

**Figure 15. Buffer/control serial bus sequence**

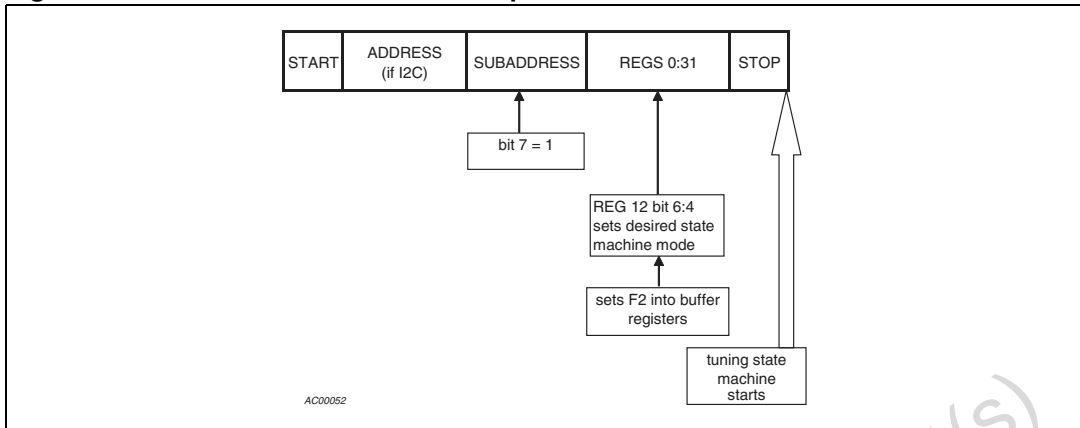

Obsolete Product(s) - Obsolete Product(s)

# 6 Registers description

Figure 16. Registers description

No	name	r/w	MSB (7)	6	5	4	3	2	1	LSB (0)	Power on default	
0	Short reg	r/w	x	x	ShAGC	ShPLL	ADCstart	ADCen	GPIOen	PWR	00h	
1	ADCctrl	r/w	ADCclk	ADCs2	ADCs1	ADCs0	RCenable	ADCaumode	Temp_pwr		00h	
2	GPIOval	r/w	GPO8_AMAGCv	GPO7_FMAGCv	GPIO6_MISO	GPIO5_Aout	GPO4_AMcas	CP_curr_switch	GPIO2io	GPIO1io	00h	
3	AGCmixCtrl	r/w	IFin1_AM_FM	KeyAGCen	FMAGCpwr	AMAGCpwr	MixinFMAM	BalunoutIMP	Mixout1	Mixout2	00h	
4	Misc1	r/w	WAIT60ms(4)	WAIT60ms(3)	WAIT60ms(2)	WAIT60ms(1)	WAIT60ms(0)	disvcc	PLLtest	AMAGC_Isink	00h	
5	DivR	r/w	divr7	divr6	divr5	divr4	divr3	divr2	divr1	divr0	00h	
6	IFAGC_SH	r/w	IFAGC_fm_AM	IFAGCthr2	IFAGCthr1	IFAGCthr0			GPIO5 output	IFsection_pwr	00h	
7	FMAGC	r/w	FMthr3	FMthr2	FMthr1	FMthr0	FMAGCmodeC1	FMAGCmodeC0	FMAGCmodeV1	FMAGCmodeV0	00h	
8	FM_AM_Vthr	r/w	AMAGCfat	AFH_MUX	Vthr5	Vthr4	Vthr3	Vthr2	Vthr1	Vthr0	00h	
9	MiXalign1	r/w	IFAMP_ictrl2	IFAMP_ictrl1	iredH	iredL	Casc_ctrl	IMRF2	IMRF1	IMRF0	00h	
10	MiXalign2	r/w	IMRph3	IMRph2	IMRph1	IMRph0	IMRG3	IMRG2	IMRG1	IMRG0	00h	
11	PLLctrl	r/w	DZ4	DZ3	DZ2	DZ1	CPcur_800u	SWfref	PLLpwr		00h	
12	PLLctrl2	r/w	FUNC	MODE2	MODE1	MODE0	DS4	DS3	DS2	DS1	00h	
13	PLLtest	r/w	POL	PFD_D1	PFD_D0	PLL4	PLL3	PLL2	PLL1	PLL0	00h	
14	Misc2	r/w	IFAGCin4ctrl	EnSMOOTH	reg48sel	IFAMP_ictrl0	RCfreq_1	RCfreq_0	VCOMag1	VCOMag0	00h	
15	WAIT_LOCK	r/w	WAIT LOCK(4)	WAIT LOCK(3)	WAIT LOCK(2)	WAIT LOCK(1)	WAIT LOCK(0)	DIVVtest	VCOext	LOCK_bit	00h	
16	AGCtc_A	r/w	IFAGCtcAM	IFAGCtcFM	AMtc1	AMtc0	Fmtc3	Fmtc2	Fmtc1	Fmtc0	00h	
17	AMAGC_A	r/w	AMthr3	AMthr2	AMthr1	AMthr0	AMAGCmodeC1	AMAGCmodeC0	AMAGCmodeV1	AMAGCmodeV0	00h	
18	GPIOm_A	r/w	GPO8hl	GPO7hl	GPIO6hl	GPIO5hl	GPO4hl		GPIO2hl	GPIO1hl	00h	
19	IFCTRL_A	r/w	IFin0_Std_IBOC	IFAmpgainA2	IFAmpgainA1	IFAmpgainA0	MixinFM	AMAGCinbuffer	RCTest		00h	
20		r/w	WAIT1ms(5)	WAIT1ms(4)	WAIT1ms(3)	WAIT1ms(2)	WAIT1ms(1)	WAIT1ms(0)			00h	
21	DivN_A1	r/w	divnA20	divnA19	divnA18	divnA17	divnA16	divnA15	divnA14	divnA13	00h	
22	DivN_A2	r/w	divnA12	divnA11	divnA10	divnA9	divnA8	divnA7	divnA6	divnA5	00h	
23	DivN_A3	r/w	divnA4	divnA3	divnA2	divnA1	divnA0				00h	
24	DivV_A	r/w	VCO1r	divVA6	divVA5	divVA4	divVA3	divVA2	divVA1	divVA0	00h	
25	CPcur_A	r/w	CPAh3	CPAh2	CPAh1	CPAh0		CPAI3	CPAI2	CPAI0	00h	
26	DAC1_A	r/w	DAC1A8	DAC1A6	DAC1A5	DAC1A4	DAC1A3	DAC1A2	DAC1A1	DAC1A0	00h	
27	DAC2_A	r/w	DAC2A8	DAC2A6	DAC2A5	DAC2A4	DAC2A3	DAC2A2	DAC2A1	DAC2A0	00h	
28	PLL_DAC_A	r/w	IQselA	VCOsw			DAC2A0	DAC1A0	DAC2off	DAC1off	00h	
29	Misc4_A	r/w	WAIT2ms(5)	WAIT2ms(4)	WAIT2ms(3)	WAIT2ms(2)	WAIT2ms(1)	WAIT2ms(0)		MIN16	00h	
30		r/w	WAIT0.5ms(5)	WAIT0.5ms(4)	WAIT0.5ms(3)	WAIT0.5ms(2)	WAIT0.5ms(1)	WAIT0.5ms(0)	AGCTest1	AGCTest0	00h	
31		r/w	IF test	ADC test	ADCDAC5	ADCDAC4	ADCDAC3	ADCDAC2	ADCDAC1	ADCDAC0	00h	
32	AGCtc_B	r/w	this byte is valid on the output if bit SHAGC is set to '1', otherwise byte Nr. 16 is valid on the output									00h
33	AMAGC_B	r/w	all bytes from 33 to 45 are valid on the output if SHPLL is set to '1', otherwise byte 17 to 29 are valid on the output									00h
34	GPIOm_B	r/w									00h	
35	IFCTRL_B	r/w									00h	
36	AMFit_B	r/w									00h	
37	DivN_B1	r/w									00h	
38	DivN_B2	r/w									00h	
39	DivN_B3	r/w									00h	
40	DivV_B	r/w									00h	
41	CPcur_B	r/w									00h	
42	DAC1_B	r/w									00h	
43	DAC2_B	r/w									00h	
44	PLL_DAC_B	r/w									00h	
45	Misc4_B	r/w									00h	
46											00h	
47											00h	
48	READ_Status	r	lock		GPIO6r	GPIO5r	MaskMetal1	MaskMetal0	MaskSet1	MaskSet0	00h	
49	READ_ADC	r		ADCok	ADC5	ADC4	ADC3	ADC2	ADC1	ADC0	00h	

Shadow register

Obsolete

## 6.1 Data byte specification

### 6.1.1 Short\_reg (0)

Table 26. Short\_reg (0)

MSB							LSB	Function
D <sub>7</sub>	D <sub>6</sub>	D <sub>5</sub>	D <sub>4</sub>	D <sub>3</sub>	D <sub>2</sub>	D <sub>1</sub>	D <sub>0</sub>	
-	-	-	-	-	-	-	0	<b>Global PWR</b> Power down the IC
-	-	-	-	-	-	-	1	Power on the IC
-	-	-	-	-	-	0	-	<b>GPIO enable</b> all GPIO in tristate
-	-	-	-	-	-	1	-	all GPIO enable
-	-	-	-	-	0	-	-	<b>ADCen</b> 6bit ADC on
-	-	-	-	-	1	-	-	6bit ADC off
-	-	-	-	0	-	-	-	<b>ADCstart</b> No conversion
-	-	-	-	1	-	-	-	Starts a single AD conversion
-	-	-	0	-	-	-	-	<b>ShPLL</b> PLL register from 17 to 31 are valid
-	-	-	1	-	-	-	-	PLL register from 33 to 47 are valid
-	-	0	-	-	-	-	-	<b>ShAGC</b> AGC TC register 16 is valid
-	-	1	-	-	-	-	-	AGC TC register 32 is valid
-	X	-	-	-	-	-	-	<b>Not used</b>
X	-	-	-	-	-	-	-	<b>Not used</b>

### 6.1.2 ADCctrl (1)

Table 27. ADCctrl (1)

MSB							LSB		Function
D <sub>7</sub>	D <sub>6</sub>	D <sub>5</sub>	D <sub>4</sub>	D <sub>3</sub>	D <sub>2</sub>	D <sub>1</sub>	D <sub>0</sub>		
-	-	-	-	-	-	-	0	<b>Temperature sensor power</b> Enabled	
							1	Disabled	
-	-	-	-	-	-	0	-	<b>ADC auto mode</b> automatic restart disable	
						1		automatic restart enable	
-	-	-	-	-	0	-	-	<b>RC oscillator enable</b> enable	
					1			disable	
-	-	-	-	X	-	-	-	<b>ADCstart (like bit 0.3)</b>	
-	0	0	0					<b>ADC input selection</b> Temp sensor	
	1	0	0					FM AGC	
	0	1	0					AM AGC	
-	1	1	0	-	-	-	-	IF AGC	
	0	0	1					VCO tuning voltage ( $3/5 * V_{tune}$ )	
	1	0	1					GP1	
	0	1	1					GP2	
	1	1	1					$2/5 * VCC$	
0	-	-	-	-	-	-	-	<b>ADC clock selection</b> ADC clock source = RC osc	
1								ADC clock source = rediv output	

6.1.3 GPIO mode (2)

Table 28. GPIO mode (2)

MSB							LSB		Function
D <sub>7</sub>	D <sub>6</sub>	D <sub>5</sub>	D <sub>4</sub>	D <sub>3</sub>	D <sub>2</sub>	D <sub>1</sub>	D <sub>0</sub>		
-	-	-	-	-	-	-	0 1	<b>GPIO1 input / output</b> Analog input to AD converter digital output	
-	-	-	-	-	-	0 1	-	<b>GPIO2 input / output</b> Analog input to AD converter Digital output	
-	-	-	-	-	0 1	-	-	<b>CP Current Switch</b> Automatic switch disabled Automatic switch enabled	
-	-	-	-	0 1	-	-	-	<b>GPIO4 input / output</b> Analog Input digital output	
-	-	-	0 1	-	-	-	-	<b>GPIO5 input / output</b> digital input output (analog or digital)	
-	-	0 1	-	-	-	-	-	<b>GPIO6 input / output</b> digital input (or MISO output in SPI mode) digital output (or MISO output in SPI mode)	
-	0 1	-	-	-	-	-	-	<b>GPIO7 input / output</b> FM AGC voltage output Digital output	
0 1	-	-	-	-	-	-	-	<b>GPIO8 input / output</b> AM AGC voltage output Digital output	

### 6.1.4 AGC and mixer control (3)

Table 29. AGC and mixer control (3)

MSB							LSB		Function
D <sub>7</sub>	D <sub>6</sub>	D <sub>5</sub>	D <sub>4</sub>	D <sub>3</sub>	D <sub>2</sub>	D <sub>1</sub>	D <sub>0</sub>		
-	-	-	-	-	-	0	0	<b>Mixout 1 / 2</b> All Off = power down mixer section	
-	-	-	-	-	-	0	1	Mixout 1 active	
-	-	-	-	-	-	1	0	Mixout 2 active	
-	-	-	-	-	-	1	1	Forbidden state	
-	-	-	-	-	0	-	-	<b>Balun output drive capability</b> Low drive capability	
-	-	-	-	-	1	-	-	High drive capability	
-	-	-	-	0	-	-	-	<b>Mixer input FM / AM selection</b> AM input active	
-	-	-	-	1	-	-	-	FM input active	
-	-	-	0	-	-	-	-	<b>AM AGC On / Off</b> Off	
-	-	-	1	-	-	-	-	On	
-	-	0	-	-	-	-	-	<b>FM AGC On / Off</b> Off	
-	-	1	-	-	-	-	-	On	
-	0	-	-	-	-	-	-	<b>Keyed AGC enable</b> Keyed AGC off	
-	1	-	-	-	-	-	-	keyed AGC on	
0	-	-	-	-	-	-	-	<b>IF input selection FM / AM</b> IF input AM	
1	-	-	-	-	-	-	-	IF input FM	

### 6.1.5 Register (4)

Table 30. Register (4)

MSB							LSB	Function
D <sub>7</sub>	D <sub>6</sub>	D <sub>5</sub>	D <sub>4</sub>	D <sub>3</sub>	D <sub>2</sub>	D <sub>1</sub>	D <sub>0</sub>	
-	-	-	-	-	-	-	0 1	<b>AMAGC Isink (2mA fixed current)</b> Off On
-	-	-	-	-	-	0 1	-	<b>PLLtest</b> Off On
-	-	-	-	-	0 1	-	-	<b>Disvcc</b> POR activated from IFVCC POR non activated from IFVCC
0 1 1	0 0 1	0 1 1	0 1 1	0 1 1	-	-	-	<b>WAIT60ms</b> 1ms (min. value) 60ms (default value) 80ms (max value)

### 6.1.6 Divider R (5)

Table 31. Divider R (5)

MSB							LSB	Divider R value
D <sub>7</sub>	D <sub>6</sub>	D <sub>5</sub>	D <sub>4</sub>	D <sub>3</sub>	D <sub>2</sub>	D <sub>1</sub>	D <sub>0</sub>	
X	-	-	-	-	-	-	X	<b>Divider R value</b> DivR0 : : DivR7



## 6.1.7 IF AGC control (6)

Table 32. IF AGC control (6)

MSB							LSB	Function
D <sub>7</sub>	D <sub>6</sub>	D <sub>5</sub>	D <sub>4</sub>	D <sub>3</sub>	D <sub>2</sub>	D <sub>1</sub>	D <sub>0</sub>	
-	-	-	-	-	-	-	0 1	<b>IF section On / Off</b> Off On
-	-	-	-	-	-	0 1	-	<b>GPIO 5 output mode</b> Off On = GPIO 5 analog output enable
-	-	-	-	X	X		-	<b>Not used</b>
-	0 0 : : 1	0 0 : : 1	0 1 : : 1	-	-	-	-	<b>IF AGC threshold</b> IF output level = 89dB $\mu$ V(AM) / 91dB $\mu$ V (FM) IF output level = 90.5dB $\mu$ V(AM) / 92.5dB $\mu$ V (FM) : : IF output level = 99dB $\mu$ V(AM) / 101dB $\mu$ V (FM)
0 1	-	-	-	-	-	-	-	<b>IF AGC mode FM / AM selection</b> FM mode AM mode

6.1.8 FM AGC (7)

Table 33. FM AGC (7)

MSB							LSB		Function
D <sub>7</sub>	D <sub>6</sub>	D <sub>5</sub>	D <sub>4</sub>	D <sub>3</sub>	D <sub>2</sub>	D <sub>1</sub>	D <sub>0</sub>		
-	-	-	-	-	-	0	0	<b>Voltage output mode</b> Off	
-	-	-	-	-	-	0	1	N/A	
-	-	-	-	-	-	1	0	Calibration mode	
-	-	-	-	-	-	1	1	Voltage output On	
-	-	-	-	0	0	-	-	<b>Current output mode</b> Off	
-	-	-	-	0	1	-	-	Constant 2mA output	
-	-	-	-	1	0	-	-	Positive current output	
-	-	-	-	1	1	-	-	Neg. / Pos. current output	
0	0	0	0	-	-	-	-	<b>FM AGC threshold</b> Mixer input level = 93dBμV (FM1) / 97dBμV (FM2)	
0	0	0	1	-	-	-	-	Mixer input level = 94dBμV (FM1) / 98dBμV (FM2)	
0	0	1	0	-	-	-	-	Mixer input level = 95dBμV (FM1) / 99dBμV (FM2)	
0	0	1	1	-	-	-	-	Mixer input level = 96dBμV (FM1) / 100dBμV (FM2)	
0	1	0	0	-	-	-	-	Mixer input level = 97dBμV (FM1) / 101dBμV (FM2)	
0	1	0	1	-	-	-	-	Mixer input level = 98dBμV (FM1) / 102dBμV (FM2)	
0	1	1	0	-	-	-	-	Mixer input level = 99dBμV (FM1) / 103dBμV (FM2)	
0	1	1	1	-	-	-	-	Mixer input level = 100dBμV (FM1) / 104dBμV (FM2)	
1	0	0	0	-	-	-	-	Mixer input level = 93dBμV (FM1) / 97dBμV (FM2)	
1	0	0	1	-	-	-	-	Mixer input level = 92dBμV (FM1) / 96dBμV (FM2)	
1	0	1	0	-	-	-	-	Mixer input level = 91dBμV (FM1) / 95dBμV (FM2)	
1	0	1	1	-	-	-	-	Mixer input level = 90dBμV (FM1) / 94dBμV (FM2)	
1	1	0	0	-	-	-	-	Mixer input level = 89dBμV (FM1) / 93dBμV (FM2)	
1	1	0	1	-	-	-	-	Mixer input level = 88dBμV (FM1) / 92dBμV (FM2)	
1	1	1	0	-	-	-	-	Mixer input level = 87dBμV (FM1) / 91dBμV (FM2)	
1	1	1	1	-	-	-	-	Mixer input level = 86dBμV (FM1) / 90dBμV (FM2)	

### 6.1.9 AGC voltage threshold (8)

Table 34. AGC voltage threshold (8)

MSB							LSB	Function
D <sub>7</sub>	D <sub>6</sub>	D <sub>5</sub>	D <sub>4</sub>	D <sub>3</sub>	D <sub>2</sub>	D <sub>1</sub>	D <sub>0</sub>	
		0	0	0	0	0	0	<b>Transfer voltage from voltage out to current out</b> 200mV 237.5mV : : 2.5625V 2.6V
		0	0	0	0	0	1	
-	-	:	:	:	:	:	:	
		1	1	1	1	1	0	
		1	1	1	1	1	1	
0	-	-	-	-	-	-	-	<b>AM fast attack</b> Off On
1								

### 6.1.10 Mixer alignment 1 (9)

Table 35. Mixer alignment 1 (9)

MSB							LSB	Function
D <sub>7</sub>	D <sub>6</sub>	D <sub>5</sub>	D <sub>4</sub>	D <sub>3</sub>	D <sub>2</sub>	D <sub>1</sub>	D <sub>0</sub>	
					0	0	0	<b>IQ-filter frequency adjust</b> +2.4MHz +1.8MHz : : 0 : -1.8MHz
					0	0	1	
-	-	-	-	-	:	:	:	
					1	0	0	
					:	:	:	
					1	1	1	
-	-	-	-	0	-	-	-	<b>Cascode control loop On / Off</b> On Off
				1				
		0	0					<b>Mixers current control</b> Normal bias Low reduction High reduction N/A
-	-	0	1	-	-	-	-	
		1	0					
		1	1					
0	0							<b>IFAMP driving capability</b> Normal Intermediate 1 Intermediate 2 High
0	1	-	-	-	-	-	-	
1	0							
1	1							

6.1.11 Mixer alignment 2 (10)

Table 36. Mixer alignment 2 (10)

MSB				LSB				Function
D <sub>7</sub>	D <sub>6</sub>	D <sub>5</sub>	D <sub>4</sub>	D <sub>3</sub>	D <sub>2</sub>	D <sub>1</sub>	D <sub>0</sub>	
				0	1	1	1	IQ-filter gain adjust
				0	1	1	0	-0.7dB
				0	1	0	1	-0.6dB
				:	:	:	:	-0.5dB
-	-	-	-	:	:	:	:	:
				0	0	0	0	0dB
				1	0	0	0	0dB
				:	:	:	:	:
				1	1	1	0	+0.6dB
				1	1	1	1	+0.7dB
								IQ-filter phase adjust
0	0	0	0					0
0	0	0	1					+0.2 deg
0	0	1	0					+0.2 deg
0	0	1	1					+0.4 deg
0	1	0	0					+0.6 deg
:	:	:	:					:
0	1	1	1	-	-	-	-	+1.2 deg
1	0	0	0					-1.2 deg
1	0	0	1					-1.0 deg
1	0	1	0					-1.0 deg
1	0	1	1					-0.8 deg
1	1	0	0					-0.6 deg
:	:	:	:					:
1	1	1	0					-0.2 deg
1	1	1	1					0

### 6.1.12 PLL control 1 (11)

Table 37. PLL control 1 (11)

MSB							LSB	Function
D <sub>7</sub>	D <sub>6</sub>	D <sub>5</sub>	D <sub>4</sub>	D <sub>3</sub>	D <sub>2</sub>	D <sub>1</sub>	D <sub>0</sub>	
-	-	-	-	-	-	-	0 1	<b>PLL enable</b> PLL Off PLL On
-	-	-	-	-	-	0 1	-	<b>Divider R enable</b> Divider R off; = div / 1 Divider R on
-	-	-	-	-	0 1	-	-	<b>Select reference input</b> Reference frequency input = LVDS Reference frequency input = Xtal
-	-	-	-	0 1	-	-	-	<b>Charge pump current 800<math>\mu</math>A</b> 0 $\mu$ A 800 $\mu$ A
0 : 1	0 : 1	0 : 1	0 : 1	- -	- -	- -	-	<b>Slope of high current CP</b> highest : lowest

### 6.1.13 PLL control 2 (12)

Table 38. PLL control 2 (12)

MSB							LSB	Function
D <sub>7</sub>	D <sub>6</sub>	D <sub>5</sub>	D <sub>4</sub>	D <sub>3</sub>	D <sub>2</sub>	D <sub>1</sub>	D <sub>0</sub>	
-	-	-	-	0 : 1	0 : 1	0 : 1	0 : 1	<b>Delay of high current CP</b> shortest : longest
-	0 0 0 0 1 1 1 1	0 0 1 1 0 0 1 1	0 1 0 1 0 1 0 1	- -	- -	- -	-	<b>State machine modes decode</b> Buffer mode Preset Search AF update Jump Check Load End
0 1	- -	- -	- -	- -	- -	- -	-	<b>Register functionality control</b> Normal/shadow mode Buffer/control mode

6.1.14 PLL test (13)

Table 39. PLL test (13)

MSB							LSB		Function
D <sub>7</sub>	D <sub>6</sub>	D <sub>5</sub>	D <sub>4</sub>	D <sub>3</sub>	D <sub>2</sub>	D <sub>1</sub>	D <sub>0</sub>		
-	-	-	X	X	1	0	-	<b>PLL test</b> Set to default	
-	0	1	-	-	-	-	-	<b>PFD</b> default	
0	-	-	-	-	-	-	-	<b>PFD polarity</b>	

6.1.15 Misc 2 (14)

Table 40. Misc 2 (14)

MSB							LSB		Function
D <sub>7</sub>	D <sub>6</sub>	D <sub>5</sub>	D <sub>4</sub>	D <sub>3</sub>	D <sub>2</sub>	D <sub>1</sub>	D <sub>0</sub>		
-	-	-	-	-	-	0	0	<b>VCO magnitude</b> 1V	
-	-	-	-	-	-	0	1	2V	
-	-	-	-	-	-	1	0	3V	
-	-	-	-	-	-	1	1	4V	
-	-	-	-	0	0	-	-	<b>Oscillation frequency of RC oscillator</b> 0.68 MHz	
-	-	-	-	0	1	-	-	1.31 MHz	
-	-	-	-	1	0	-	-	1.92 MHz	
-	-	-	-	1	1	-	-	2.49 MHz	
-	-	-	0	-	-	-	-	<b>IFAMP current control</b> Normal bias	
-	-	-	1	-	-	-	-	High current mode bias	
-	-	0	-	-	-	-	-	<b>Reg48sel</b> ShAGC and ShPLL on D48<1:0>	
-	-	1	-	-	-	-	-	MaskMetal and MaskSet on D48<1:0>	
-	0	-	-	-	-	-	-	<b>EnSMOOTH</b> Smooth disabled	
-	1	-	-	-	-	-	-	Smooth enabled	
0	-	-	-	-	-	-	-	<b>IFAGC control when IN4 selected</b> Normal	
1	-	-	-	-	-	-	-	Thresholds shift	

### 6.1.16 Wait lock (15)

Table 41. Wait lock (15)

MSB							LSB		Function
D <sub>7</sub>	D <sub>6</sub>	D <sub>5</sub>	D <sub>4</sub>	D <sub>3</sub>	D <sub>2</sub>	D <sub>1</sub>	D <sub>0</sub>		
-	-	-	-	-	-	0	0	<b>Test</b> D18<0>	
						0	1	LOCK_bit	
						1	0	CMPout	
						1	1	VdivOUT	
0	0	0	0	0	-	-	-	<b>Wait lock</b> 0.04ms (min. value)	
0	0	1	1	0	-	-	-	1ms (default value)	
1	1	1	1	1	-	-	-	5.08ms (default value)	

### 6.1.17 AGC time constant settings (16 / 32)

Table 42. AGC time constant settings (16 / 32)

MSB							LSB		Function
D <sub>7</sub>	D <sub>6</sub>	D <sub>5</sub>	D <sub>4</sub>	D <sub>3</sub>	D <sub>2</sub>	D <sub>1</sub>	D <sub>0</sub>		
-	-	-	-	-	-	0	0	<b>FM AGC decay time constant</b>	
						0	1	D1	
						1	0	D2	
								D3	
-	-	-	-	0	0	-	-	<b>FM AGC attack time constant</b>	
				0	1			A1	
				1	0			A2	
								A3	
-	-	0	0	-	-	-	-	<b>AM AGC time constant</b>	
		0	1					T1	
		1	0					T2	
								T3	
-	0	-	-	-	-	-	-	<b>IF AGC time constant FM</b>	
	1							U1	
								U2	
0	-	-	-	-	-	-	-	<b>IF AGC time constant AM</b>	
1								S1	
								S2	

6.1.18 AMAGC control (17 / 33)

Table 43. AMAGC control (17 / 33)

MSB				LSB				Function
D <sub>7</sub>	D <sub>6</sub>	D <sub>5</sub>	D <sub>4</sub>	D <sub>3</sub>	D <sub>2</sub>	D <sub>1</sub>	D <sub>0</sub>	
-	-	-	-	-	-	0	0	<b>AM AGC voltage output mode</b> Off
-	-	-	-	-	-	0	1	Voltage output / sense internal
-	-	-	-	-	-	1	0	Calibration
-	-	-	-	-	-	1	1	Voltage output / sense external
-	-	-	-	0	0	-	-	<b>AM AGC current output mode</b> Off
-	-	-	-	0	1	-	-	Constant 2mA
-	-	-	-	1	0	-	-	Positive current
-	-	-	-	1	1	-	-	N/A
0	0	0	0	-	-	-	-	<b>AM AGC thresholds</b> Mixer input level = 94 dB $\mu$ V
0	0	0	1	-	-	-	-	Mixer input level = 95 dB $\mu$ V
0	0	1	0	-	-	-	-	Mixer input level = 96 dB $\mu$ V
0	0	1	1	-	-	-	-	Mixer input level = 97 dB $\mu$ V
0	1	0	0	-	-	-	-	Mixer input level = 98 dB $\mu$ V
0	1	0	1	-	-	-	-	Mixer input level = 99 dB $\mu$ V
0	1	1	0	-	-	-	-	Mixer input level = 100 dB $\mu$ V
0	1	1	1	-	-	-	-	Mixer input level = 101 dB $\mu$ V
1	0	0	0	-	-	-	-	Mixer input level = 94 dB $\mu$ V
1	0	0	1	-	-	-	-	Mixer input level = 93 dB $\mu$ V
1	0	1	0	-	-	-	-	Mixer input level = 92 dB $\mu$ V
1	0	1	1	-	-	-	-	Mixer input level = 91 dB $\mu$ V
1	1	0	0	-	-	-	-	Mixer input level = 90 dB $\mu$ V
1	1	0	1	-	-	-	-	Mixer input level = 89 dB $\mu$ V
1	1	1	0	-	-	-	-	Mixer input level = 88 dB $\mu$ V
1	1	1	1	-	-	-	-	Mixer input level = 87 dB $\mu$ V



### 6.1.19 GPIO output level control (18 / 34)

Table 44. GPIO output level control (18 / 34)

MSB							LSB		Function
D <sub>7</sub>	D <sub>6</sub>	D <sub>5</sub>	D <sub>4</sub>	D <sub>3</sub>	D <sub>2</sub>	D <sub>1</sub>	D <sub>0</sub>		
							0	<b>GPIOx high / low output level</b>	
							1	GPIO1 low	
							0	GPIO1 high	
							1	GPIO2 low	
								GPIO2 high	
	:	:	:	:	:			:	
	X	X	X	X	X			GPIOx low / high	
	:	:	:	:	:			:	
0								GPIO8 low	
1								GPIO8 high	

### 6.1.20 IF control (19 / 35)

Table 45. IF control (19 / 35)

MSB							LSB		Function
D <sub>7</sub>	D <sub>6</sub>	D <sub>5</sub>	D <sub>4</sub>	D <sub>3</sub>	D <sub>2</sub>	D <sub>1</sub>	D <sub>0</sub>		
-	-	-	-	-	-	-	X	<b>Not used</b>	
-	-	-	-	-	-	0	-	<b>RC test</b>	
-	-	-	-	-	-	1	-	Test enabled	
-	-	-	-	-	0	-	-	Test disabled	
-	-	-	-	-	1	-	-	<b>AMAGC input buffer</b>	
-	-	-	-	-	-	-	-	Buffer enabled	
-	-	-	-	-	-	-	-	Buffer disabled	
-	-	-	-	0	-	-	-	<b>Mixer input selection for FM</b>	
-	-	-	-	1	-	-	-	FM1 mixer input	
-	-	-	-	-	-	-	-	FM2 mixer input	
-	0	0	0	-	-	-	-	<b>IF amplifier Gain</b>	
-	0	0	1	-	-	-	-	25dB (input1-3) / 19dB (input4)	
-	:	:	:	-	-	-	-	27dB (input1-3) / 21dB (input4)	
-	1	1	0	-	-	-	-	:	
-	1	1	1	-	-	-	-	37dB (input1-3) / 31dB (input4)	
-	-	-	-	-	-	-	-	39dB (input1-3) / 33dB (input4)	
0	-	-	-	-	-	-	-	<b>IF input selection analog / IBOC</b>	
1	-	-	-	-	-	-	-	IBOC	
								Analog	

**6.1.21 AF state machine wait time 1 (20 / 36)**

**Table 46. AF state machine wait time 1 (20 / 36)**

MSB							LSB	Function
D <sub>7</sub>	D <sub>6</sub>	D <sub>5</sub>	D <sub>4</sub>	D <sub>3</sub>	D <sub>2</sub>	D <sub>1</sub>	D <sub>0</sub>	
-	-	-	-	-	-	-	X	Not used
-	-	-	-	-	-	X		Not used
0	0	0	0	0	0	-	-	<b>WAIT 1ms</b> 0.04ms (min. value) 1ms (default value)
0	0	1	1	0	0			

**6.1.22 PLL main divider (N-divider) 1 (21 / 37)**

**Table 47. PLL main divider (N-divider) 1 (21 / 37)**

MSB							LSB	Function
D <sub>7</sub>	D <sub>6</sub>	D <sub>5</sub>	D <sub>4</sub>	D <sub>3</sub>	D <sub>2</sub>	D <sub>1</sub>	D <sub>0</sub>	
X	X	X	X	X	X	X	X	<b>Divider N value</b> M8 M9 M10 M11 M12 M13 M14 M15

**6.1.23 PLL main divider (N-divider) 2 (22 / 38)**

**Table 48. PLL main divider (N-divider) 2 (22 / 38)**

MSB							LSB	Function
D <sub>7</sub>	D <sub>6</sub>	D <sub>5</sub>	D <sub>4</sub>	D <sub>3</sub>	D <sub>2</sub>	D <sub>1</sub>	D <sub>0</sub>	
X	X	X	X	X	X	X	X	<b>Divider N value</b> M0 M1 M2 M3 M4 M5 M6 M7

### 6.1.24 PLL main divider (N-divider) 3 (23 / 39)

Table 49. PLL main divider (N-divider) 3 (23 / 39)

MSB							LSB	Function
D <sub>7</sub>	D <sub>6</sub>	D <sub>5</sub>	D <sub>4</sub>	D <sub>3</sub>	D <sub>2</sub>	D <sub>1</sub>	D <sub>0</sub>	
X	X	X	X	X	-	-	-	<b>Divider N value</b> A0 A1 A2 A3 A4

### 6.1.25 PLL Divider ratio calculation

Table 50. PLL Divider ratio calculation

M counter							A counter					Notes
M16	M15	...	M7	...	M1	M0	A4	A3	A2	A1	A0	$N = 32 * P + A$ $M = 32$ $N = M * P + A$ $M > 32$ (P=32)

### 6.1.26 VCO divider (V-divider) (24 / 40)

Table 51. VCO divider (V-divider) (24 / 40)

MSB							LSB	Function
D <sub>7</sub>	D <sub>6</sub>	D <sub>5</sub>	D <sub>4</sub>	D <sub>3</sub>	D <sub>2</sub>	D <sub>1</sub>	D <sub>0</sub>	
-	X	X	X	X	X	X	X	<b>Divider V value</b> V0 V1 V2 V3 V4 V5 V6
0 1	- -	- -	- -	- -	- -	- -	- -	<b>VCO range selection</b> Range 2 Range 1

6.1.27 Charge pump current (25 / 41)

Table 52. Charge pump current (25 / 41)

MSB							LSB	Function
D <sub>7</sub>	D <sub>6</sub>	D <sub>5</sub>	D <sub>4</sub>	D <sub>3</sub>	D <sub>2</sub>	D <sub>1</sub>	D <sub>0</sub>	
-	-	-	-	X	X	X	X	<b>Low current charge pump</b> 50 μA 100 μA 200 μA 400 μA
X	X	X	X	-	-	-	-	<b>High current charge pump</b> 0.5 mA 1mA 2mA 4mA

6.1.28 Tuning DAC 1 (26 / 42)

Table 53. Tuning DAC 1 (26 / 42)

MSB							LSB	Function
D <sub>7</sub>	D <sub>6</sub>	D <sub>5</sub>	D <sub>4</sub>	D <sub>3</sub>	D <sub>2</sub>	D <sub>1</sub>	D <sub>0</sub>	
X	X	X	X	X	X	X	X	<b>DAC 1 voltage 8..1</b> DAC1_1 DAC1_2 DAC1_3 DAC1_4 DAC1_5 DAC1_6 DAC1_7 DAC1_8

### 6.1.29 Tuning DAC 2 (27 / 43)

Table 54. Tuning DAC 2 (27 / 43)

MSB							LSB	Function
D <sub>7</sub>	D <sub>6</sub>	D <sub>5</sub>	D <sub>4</sub>	D <sub>3</sub>	D <sub>2</sub>	D <sub>1</sub>	D <sub>0</sub>	
X	X	X	X	X	X	X	X	<b>DAC 2 voltage 8..1</b> DAC2_1 DAC2_2 DAC2_3 DAC2_4 DAC2_5 DAC2_6 DAC2_7 DAC2_8

Note:  $DAC\ output\ voltage = 600mV + DACval * 9mV$

### 6.1.30 Different controls (28 / 44)

Table 55. Different controls (28 / 44)

MSB							LSB	Function
D <sub>7</sub>	D <sub>6</sub>	D <sub>5</sub>	D <sub>4</sub>	D <sub>3</sub>	D <sub>2</sub>	D <sub>1</sub>	D <sub>0</sub>	
-	-	-	-	-	-	-	0 1	<b>DAC 1 On / Off</b> Off On
-	-	-	-	-	-	0 1	-	<b>DAC 2 On / Off</b> Off On
-	-	-	-	-	X	-	-	<b>DAC 1_0</b>
-	-	-	-	X	-	-	-	<b>DAC 2_0</b>
-	-	X	X	-	-	-	-	<b>Not used</b>
-	X	-	-	-	-	-	-	<b>Not used</b>
0 1	-	-	-	-	-	-	-	<b>IQ phase select</b> I anticipates Q Q anticipates I

6.1.31 Misc 3 (29 / 45)

Table 56. Misc 3 (29 / 45)

MSB							LSB		Function
D <sub>7</sub>	D <sub>6</sub>	D <sub>5</sub>	D <sub>4</sub>	D <sub>3</sub>	D <sub>2</sub>	D <sub>1</sub>	D <sub>0</sub>		
-	-	-	-	-	-	-	X	PLL N divider MSB M16	
-	-	-	-	-	-	X		Not used	
0	0	0	0	0	0	-	-	WAIT 2ms 0.08ms (min. value) 2ms (default value) 5.04ms (default value)	
0	1	1	0	0	1	-	-		
1	1	1	1	1	1	-	-		

6.1.32 Analog test select (30 / 46)

Table 57. Analog test select (30 / 46)

MSB							LSB		Function
D <sub>7</sub>	D <sub>6</sub>	D <sub>5</sub>	D <sub>4</sub>	D <sub>3</sub>	D <sub>2</sub>	D <sub>1</sub>	D <sub>0</sub>		
-	-	-	-	-	-	0	0	Analog test output signal select	
-	-	-	-	-	-	0	1	IF AGC	
-	-	-	-	-	-	1	0	FM AGC	
-	-	-	-	-	-	1	0	AMAGC	
-	-	-	-	-	-	1	1	DAC voltage of ADC	
0	0	0	0	0	0	-	-	WAIT 0.5ms 0.02ms (min. value) 0.5ms (default value) 5.06ms (max value)	
0	0	0	1	1	0	-	-		
1	1	1	1	1	1	-	-		

### 6.1.33 AD converter test (31 / 47)

Table 58. AD converter test (31 / 47)

MSB							LSB		Function
D <sub>7</sub>	D <sub>6</sub>	D <sub>5</sub>	D <sub>4</sub>	D <sub>3</sub>	D <sub>2</sub>	D <sub>1</sub>	D <sub>0</sub>		
-	-	X	X	X	X	X	X	<b>ADC DAC direct programming</b> DAC 0 DAC 1 DAC 2 DAC 3 DAC 4 DAC 5	
-	0 1	-	-	-	-	-	-	<b>ADC test enable</b> Off On	
0 1	-	-	-	-	-	-	-	<b>AGC test enable</b> Off On	

### 6.1.34 Read 1 (48)

Table 59. Read 1 (48)

MSB							LSB		Function
D <sub>7</sub>	D <sub>6</sub>	D <sub>5</sub>	D <sub>4</sub>	D <sub>3</sub>	D <sub>2</sub>	D <sub>1</sub>	D <sub>0</sub>		
-	-	-	-	-	-	0 0 1 1	0 1 0 1	<b>Mask set revision</b> A B C D	
-	-	-	-	0 0 1 1	0 1 0 1	-	-	<b>Metal mask revision</b> A B C D	
-	-	-	0 1	-	-	-	-	<b>GPIO 5 level</b> low high	
-	-	0 1	-	-	-	-	-	<b>GPIO 6 level</b> low high	

6.1.35 Read 2 (49)

Table 60. Read 2 (49)

MSB							LSB	Function
D <sub>7</sub>	D <sub>6</sub>	D <sub>5</sub>	D <sub>4</sub>	D <sub>3</sub>	D <sub>2</sub>	D <sub>1</sub>	D <sub>0</sub>	
-	-	X	X	X	X	X	X	<b>AD converter result</b> ADC0 ADC1 ADC2 ADC3 ADC4 ADC5
-	0 1	-	-	-	-	-	-	<b>AD converter result status</b> Not OK OK

Obsolete Product(s) - Obsolete Product(s)





# 8 Package information

In order to meet environmental requirements, ST offers these devices in different grades of ECOPACK® packages, depending on their level of environmental compliance. ECOPACK® specifications, grade definitions and product status are available at: [www.st.com](http://www.st.com).

ECOPACK® is an ST trademark.

**Figure 18. LQFP64 (10x10x1.4mm) exposed pad down mechanical data and package dimensions (exposed pad size for D2 and E2: 4.5mm max.)**

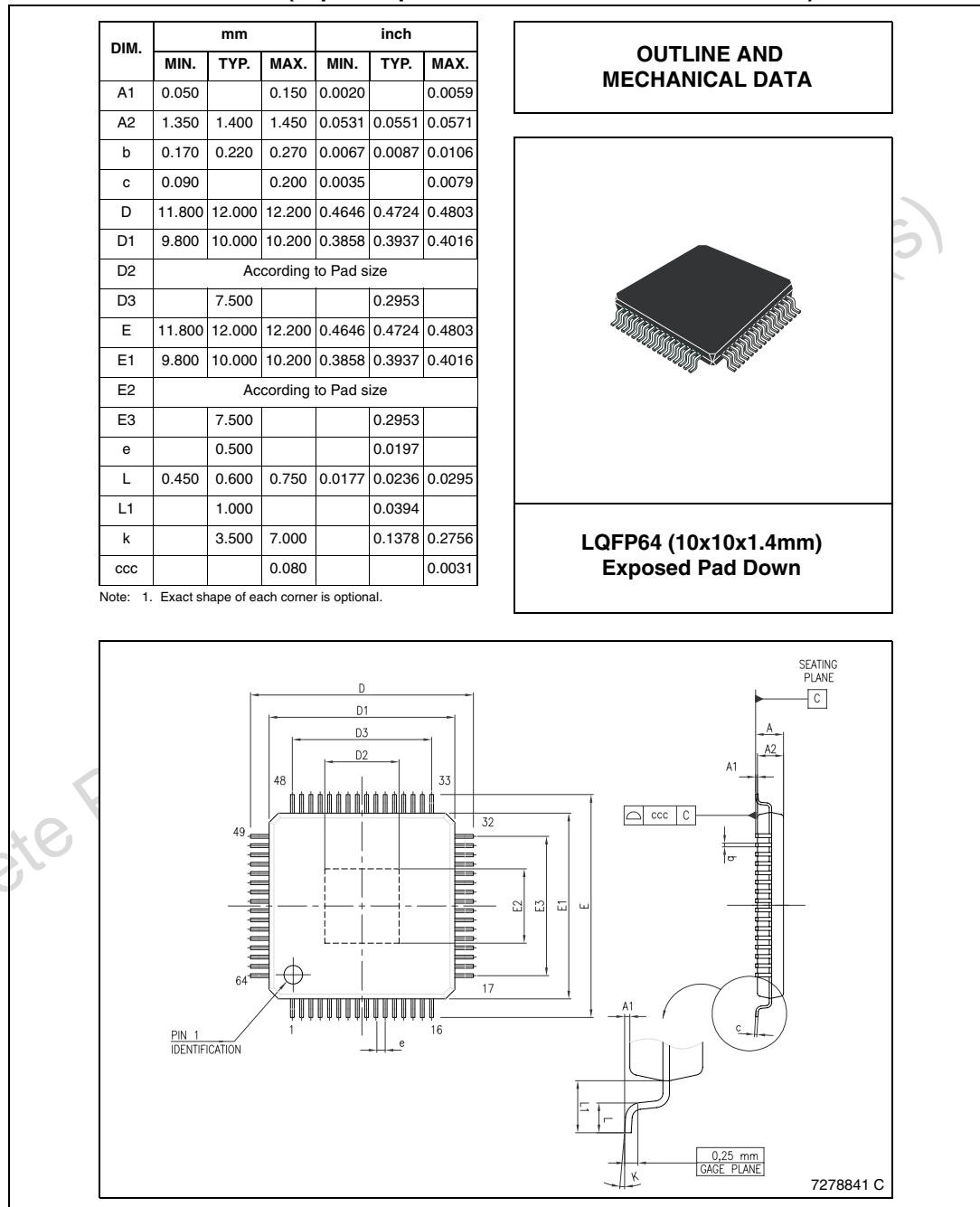

## 9 Revision history

**Table 61. Document revision history**

Date	Revision	Changes
07-Mar-2007	1	Initial release.
04-Jun-2007	2	Minor text changes.
17-Dec-2009	3	Modify <a href="#">Table 24: Serial data interface on page 28</a> .

Obsolete Product(s) - Obsolete Product(s)

**Please Read Carefully:**

Information in this document is provided solely in connection with ST products. STMicroelectronics NV and its subsidiaries ("ST") reserve the right to make changes, corrections, modifications or improvements, to this document, and the products and services described herein at any time, without notice.

All ST products are sold pursuant to ST's terms and conditions of sale.

Purchasers are solely responsible for the choice, selection and use of the ST products and services described herein, and ST assumes no liability whatsoever relating to the choice, selection or use of the ST products and services described herein.

No license, express or implied, by estoppel or otherwise, to any intellectual property rights is granted under this document. If any part of this document refers to any third party products or services it shall not be deemed a license grant by ST for the use of such third party products or services, or any intellectual property contained therein or considered as a warranty covering the use in any manner whatsoever of such third party products or services or any intellectual property contained therein.

**UNLESS OTHERWISE SET FORTH IN ST'S TERMS AND CONDITIONS OF SALE ST DISCLAIMS ANY EXPRESS OR IMPLIED WARRANTY WITH RESPECT TO THE USE AND/OR SALE OF ST PRODUCTS INCLUDING WITHOUT LIMITATION IMPLIED WARRANTIES OF MERCHANTABILITY, FITNESS FOR A PARTICULAR PURPOSE (AND THEIR EQUIVALENTS UNDER THE LAWS OF ANY JURISDICTION), OR INFRINGEMENT OF ANY PATENT, COPYRIGHT OR OTHER INTELLECTUAL PROPERTY RIGHT.**

**UNLESS EXPRESSLY APPROVED IN WRITING BY AN AUTHORIZED ST REPRESENTATIVE, ST PRODUCTS ARE NOT RECOMMENDED, AUTHORIZED OR WARRANTED FOR USE IN MILITARY, AIR CRAFT, SPACE, LIFE SAVING, OR LIFE SUSTAINING APPLICATIONS, NOR IN PRODUCTS OR SYSTEMS WHERE FAILURE OR MALFUNCTION MAY RESULT IN PERSONAL INJURY, DEATH, OR SEVERE PROPERTY OR ENVIRONMENTAL DAMAGE. ST PRODUCTS WHICH ARE NOT SPECIFIED AS "AUTOMOTIVE GRADE" MAY ONLY BE USED IN AUTOMOTIVE APPLICATIONS AT USER'S OWN RISK.**

Resale of ST products with provisions different from the statements and/or technical features set forth in this document shall immediately void any warranty granted by ST for the ST product or service described herein and shall not create or extend in any manner whatsoever, any liability of ST.

ST and the ST logo are trademarks or registered trademarks of ST in various countries.

Information in this document supersedes and replaces all information previously supplied.

The ST logo is a registered trademark of STMicroelectronics. All other names are the property of their respective owners.

© 2009 STMicroelectronics - All rights reserved

STMicroelectronics group of companies

Australia - Belgium - Brazil - Canada - China - Czech Republic - Finland - France - Germany - Hong Kong - India - Israel - Italy - Japan - Malaysia - Malta - Morocco - Philippines - Singapore - Spain - Sweden - Switzerland - United Kingdom - United States of America

[www.st.com](http://www.st.com)