

REVISION			
REV.	DESCRIPTION	DATE	APPROVED

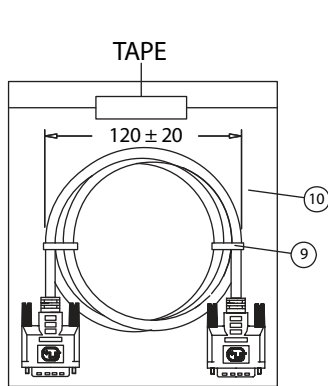
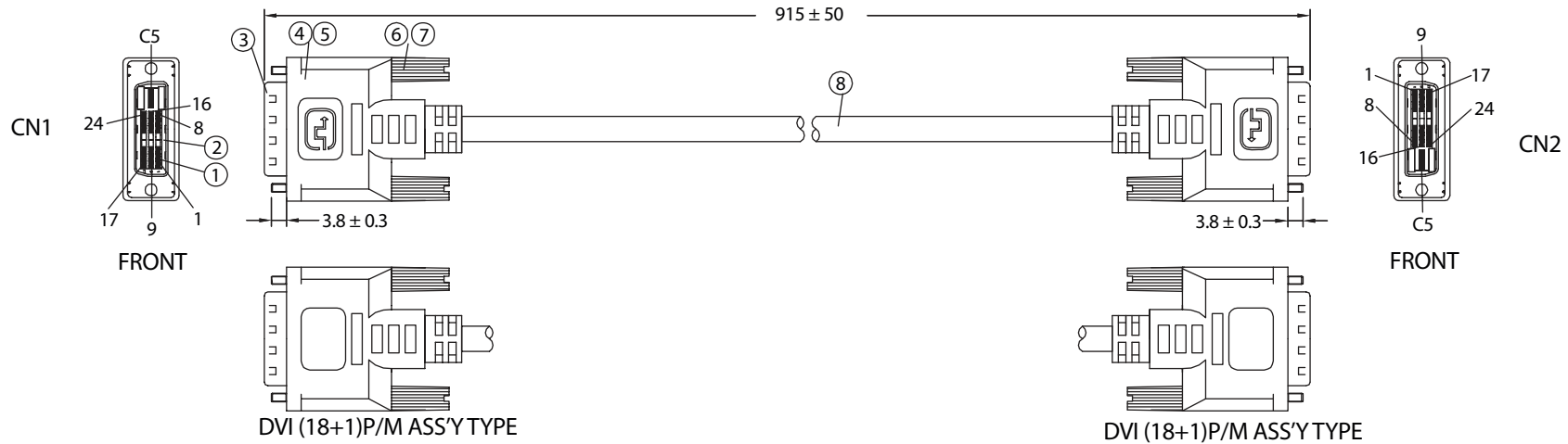

PIN OUT			
CN1	CN2	CN1	CN2
1 — WHITE	1	15 — BLACK	15
2 — ORANGE	2	16 — BROWN	16
3 — DRAIN	3	17 — WHITE	17
6 — WHITE	6	18 — YELLOW	18
7 — YELLOW	7	19 — DRAIN	19
9 — WHITE	9	23 — WHITE	23
10 — BLACK	10	24 — RED	24
11 — DRAIN	11	22 — DRAIN	22
14 — RED	14	SHELL — BRAID	SHELL

No.	PARTS NAME	SPECIFICATION STANDARD	QTY	REMARKS
①	DVI (18+1)P/M-CONTACT	BRASS/GOLD PLATED SOLDER TYPE	38	
②	DVI (18+1)P/M-INSULATOR	THERMOPLASTIC/BLACK UL 94V-0	2	
③	DVI (18+1)P/M-SHELL	STEEL NICKEL PLATED	2	
④	CAN	STEEL TIN PLATED	2	
⑤	DVI (18+1)P/M-COVER	45P PVC / COLOR: BEIGE	2	
⑥	THUMB SCREW	#4-40 2.8*45, NICKEL PLATED	4	
⑦	SCREW-MOLD	35P PVC / COLOR: BLACK	4	
⑧	CABLE DVI 18+1 UL20276	KL03006ABK01A	1	
⑨	MINI TIE	PE/BLACK	2	
⑩	POLYBAG	PE/0.08x160x200	1	

NOTES:

- CABLE: UL20276 28AWG
(28AWGx1P+DW+AL)x4P+28AWGx3C+28AWGx1P+MYLAR+FOIL+BD
OUTER JACKET PVC OD: 7.0 ± 0.2 COLOR: BEIGE
PRINTING: "E166307 AWM 20276 28AWG 80°C 30V VW-1
LOW VOLTAGE COMPUTER CABLE"
- CONNECTORS: DVI(18+1)P/M-DVI(18+1)P/M
- HOOD: ASS'Y TYPE, COLOR: BEIGE
- CABLE ELECTRICAL TEST:
<1>.100% OPEN SHORT & MISS WIRE TEST
<2>.INSULATION RESISTANCE: DC400V 10M ohm MIN.
<3>.CONDUCTOR RESISTANCE: 3 ohm MAX.
- PACKING: 1PC/POLYBAG

Dim range (mm)	Tolerance +/- (mm)	Qualtek Electronics Corp. WCI DIVISION		
		Part Number: 1321004-03		RoHS Compliant
0-1	0.15	Description: DVI (18+1)P/M - DVI (18+1)P/M		
1-6	0.20			
6-18	0.30			
18-50	0.50			
50-120	0.70	Drawn / Date	Checked / Date	Approved / Date
120-250	0.90	B.Grubb 03-13-07	03-13-07	JJH / 03-13-07
250-500	1.20			