

NOTES:

1. MATERIALS AND FINISHES:
 BODY - STAINLESS STEEL, PASSIVATED
 CONTACT - BeCu, GOLD PLATING
 INSULATOR - PTFE, NATURAL
2. ELECTRICAL:
 A. IMPEDANCE: 50 OHM
3. MECHANICAL:
 A. DURABILITY: 500 CYCLES MIN.
 B. TEMPERATURE RANGE: -65° C TO +165° C

4. FOR DEINSTALLATION TORQUE GREATER THAN 20 IN-LBS,
 INSTALLATION TORQUE MUST BE GREATER THAN 50 IN-LBS.
5. RECOMMENDED MATING TORQUE 5 TO 8 IN-LBS.
6. PACKAGING:
 A. QUANTITY: SINGLE PACK
 B. MARKING: BAG TO BE MARKED
 "AMPHENOL RF, 901-9911, AND DATE CODE"

THIRD ANGLE PROJ.

REV		DESCRIPTION	DATE	ECO	APPR
A		RELEASE TO MFG.	19-Dec-95	41026	PB/RN
B		REDRAWN IN PRO-E	6/1/15	50343	NR

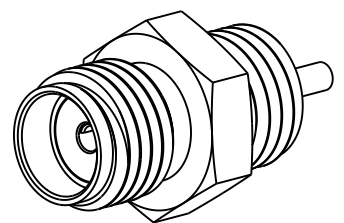

SCALE 3.000

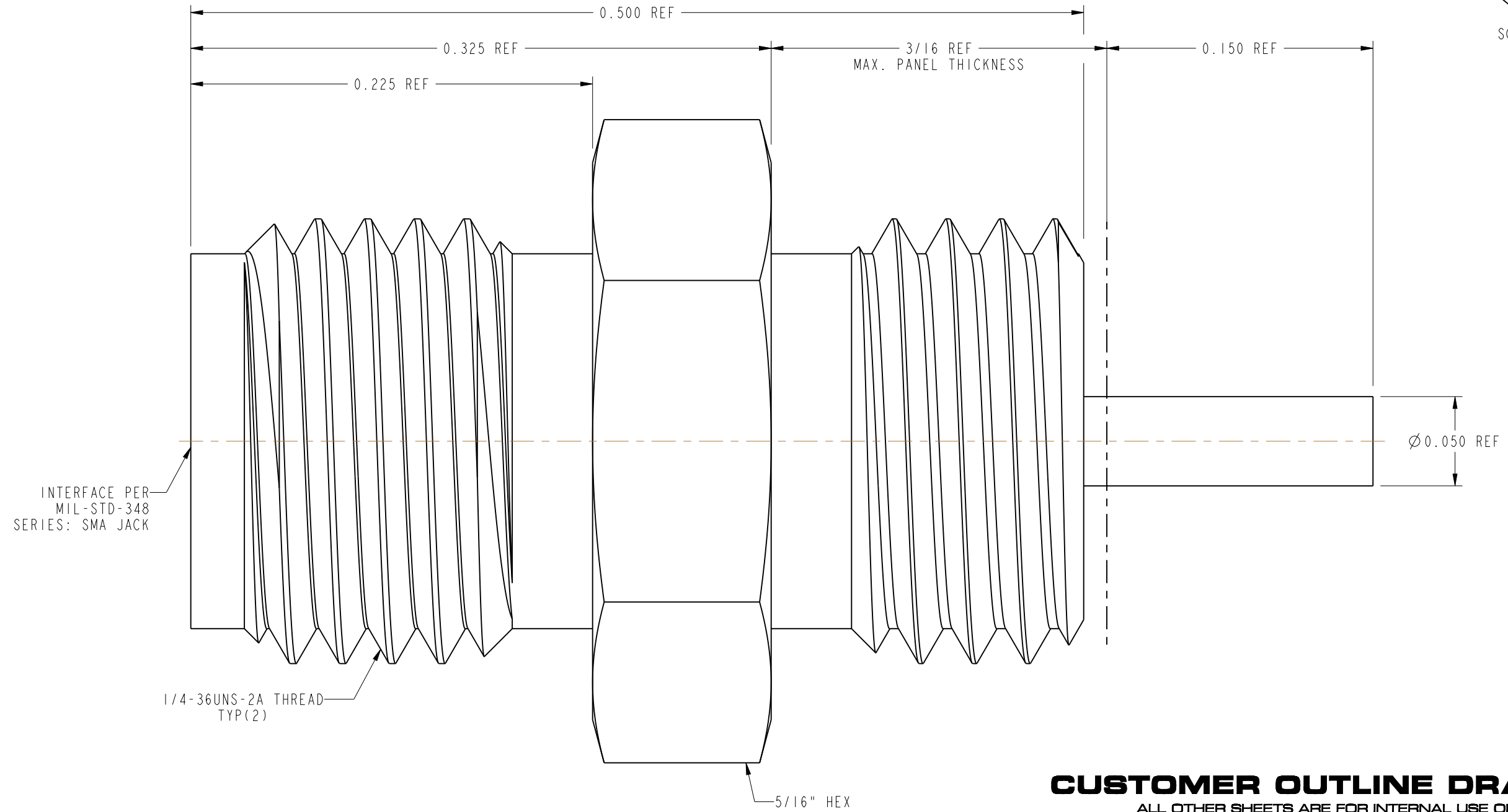

CUSTOMER OUTLINE DRAWING
 ALL OTHER SHEETS ARE FOR INTERNAL USE ONLY

UNLESS OTHERWISE SPECIFIED, DIMENSIONS ARE IN INCHES AND TOLERANCES ARE: 2 PLACE DECIMAL 3 PLACE DECIMAL ANGLES ±.015 (0,381 mm) ±.005 (0,127 mm) ± 1°	MATERIAL	DRAWN	DATE	TITLE		Amphenol RF www.amphenolrf.com
	SEE NOTES	RAJAGOPAL N	14-Jan-15	SMA STR JACK FRONT MOUNT RECEPTACLE		
NOTICE - These drawings, specifications, or other data (1) are, and remain the property of Amphenol corp. (2) must be returned upon request; and (3) are confidential and not to be disclosed to any person other than those to whom they are given by Amphenol Corp. the furnishing of these drawings, specifications, or other data by Amphenol Corp., or to any other person to anyone for any purpose is not to be regarded by implication or otherwise in any manner licensing, granting rights to permitting such holder or any other person to manufacture, use or sell any product, process or design, patented or otherwise, that may in any way be related to or disclosed by said drawings, specifications, or other data.	REFERENCE	ENGINEER	DATE	SCALE: 15.0:1.0 SHEET 2 OF 2		DRAWING NO. 901-9911
	EAR # 111-964780 3 & 615X-1393-400	K. CAPOZZI	14-Jan-15	DWG SIZE B		ITEM NO. 901-9911
	CONFIGURATION LEVEL: In Work	APPROVED	K. CAPOZZI	DATE	REV	PART NO. 901-9911
FINISH			6/1/15	B		