

Product Family: 2-Terminal Low Ohm Current Sense Resistors

Part Number Series: D1WKL Series

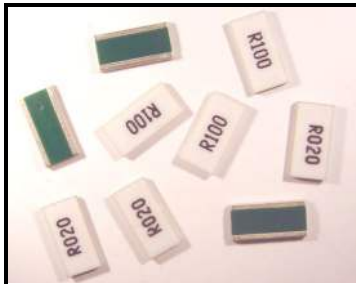

	<p>Construction:</p> <ul style="list-style-type: none"> • High purity alumina substrate • Metal foil resistive element • Epoxy-resin overcoat • Non-wrapped electrodes • Sn100 terminations • RoHS compliant and Pb free • Inherently Anti-Sulfur 	<p>Features:</p> <ul style="list-style-type: none"> • Resistances from 1mΩ~700mΩ • TCR's down to ±50ppm/°C • Optimal linearity in I/V conversion • Short and long side electrode styles available • Moisture sensitivity level = 1
--	---	--

Description:
 These low ohm current sense resistors are designed for tight resistance tolerance, low noise, long-term stability and high heat dissipation capability in a small package. This series is ideal for use in power management modules, motor control circuits and automotive applications. This series varies from the WEL series as it has non-wrapped electrodes.

Product Construction:

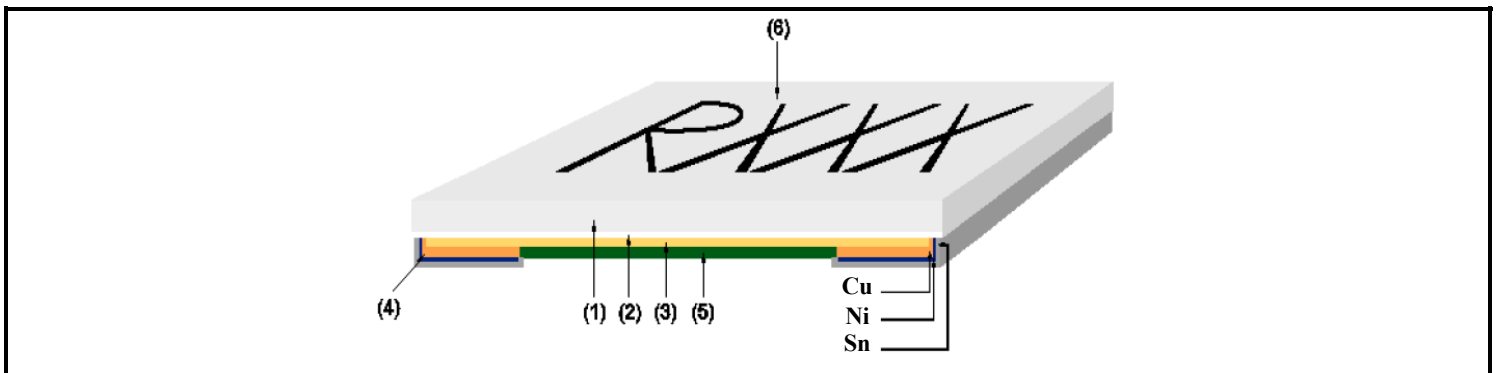

Number	Description
1	Substrate (alumina ceramic)
2	Adhesion layer (epoxy)
3	Resistive element (Cu alloy foil)
4	Terminal electrodes (Cu, Ni, Sn)
5	Protective coating (flame-retardant epoxy)
6	Marking* (flame-retardant epoxy)

* Note: Marking is 2 digits (XX) for 0603 case size, 3 digits (XXX) for 0805 and 0508 case sizes, and 4 digits (RXXX) for all other case sizes.

Part Numbering: Ex: D1WKL0508MR010F-T5

Series Name	English Size (Metric Size)	Material Code	Resistance Value	Resistance Tolerance	T&R Packaging Quantity
D1WKL	(Refer to "type" in the electrical tables)	M	Ex. R010 = 10mΩ R100 = 100mΩ (Refer to electrical tables)	D = ±0.5%* F = ±1.0%	-T1 = 1,000 pcs/reel -T2 = 2,000 pcs/reel -T4 = 4,000 pcs/reel -T5 = 5,000 pcs/reel (Refer to electrical tables)

* Note: ±0.5% (D) tolerance is not available for all resistance values. See electrical specifications table.

Product Dimensions:

Type A: Short Side Electrode

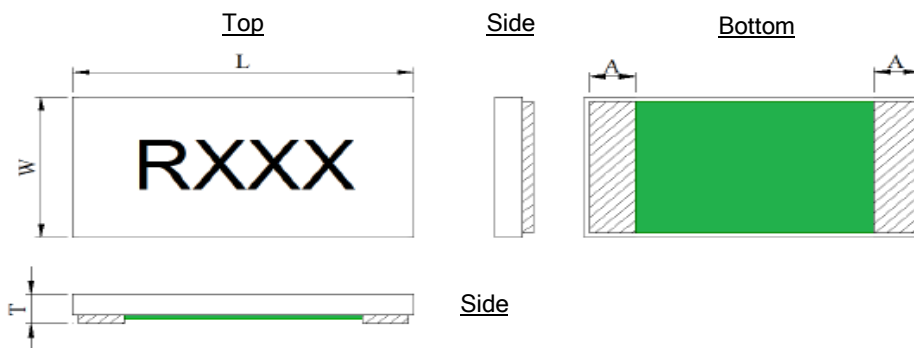

All dimensions are shown in inches, mm in parentheses.

Dimension (Metric)	Electrode Type	Resistance Range	L	W	A	T
D1WKL0603M (1608)	A	5mΩ	0.063 ±0.008 (1.60 ±0.20)	0.031 ±0.008 (0.80 ±0.20)	0.014 ±0.008 (0.35 ±0.20)	0.024 ±0.008 (0.60 ±0.20)
		6mΩ~100mΩ			0.010 ±0.008 (0.25 ±0.20)	
D1WKL0805M (2012)	A	3mΩ	0.079 ±0.008 (2.00 ±0.20)	0.050 ±0.008 (1.25 ±0.20)	0.020 ±0.008 (0.50 ±0.20)	0.024 ±0.008 (0.60 ±0.20)
		4mΩ~500mΩ			0.014 ±0.008 (0.35 ±0.20)	
D1WKL1206M (3216)	A	3mΩ	0.126 ±0.008 (3.20 ±0.20)	0.063 ±0.008 (1.60 ±0.20)	0.041 ±0.008 (1.05 ±0.20)	0.024 ±0.008 (0.60 ±0.20)
		4mΩ~700mΩ			0.021 ±0.008 (0.53 ±0.20)	
D1WKL2010M (5025)	A	2mΩ~3mΩ	0.197 ±0.008 (5.00 ±0.20)	0.098 ±0.008 (2.50 ±0.20)	0.077 ±0.012 (1.95 ±0.30)	0.024 ±0.008 (0.60 ±0.20)
		4mΩ~700mΩ			0.022 ±0.012 (0.55 ±0.30)	
D1WKL2512M (6432)	A	2mΩ	0.248 ±0.012 (6.30 ±0.30)	0.122 ±0.012 (3.10 ±0.30)	0.104 ±0.008 (2.65 ±0.20)	0.024 ±0.008 (0.60 ±0.20)
		3mΩ			0.096 ±0.008 (2.45 ±0.20)	
		4mΩ~700mΩ			0.035 ±0.008 (0.90 ±0.20)	
D1WKL4320M (11050)	A	2mΩ	0.433 ±0.012 (11.0 ±0.30)	0.197 ±0.012 (5.00 ±0.30)	0.187 ±0.012 (4.75 ±0.30)	0.024 ±0.008 (0.60 ±0.20)
		3mΩ			0.173 ±0.012 (4.40 ±0.30)	
		4mΩ~100mΩ			0.087 ±0.012 (2.21 ±0.30)	
D1WKL4527M (11470)	A	2mΩ	0.453 ±0.040 (11.5 ±1.00)	0.276 ±0.040 (7.00 ±1.00)	0.191 ±0.016 (4.85 ±0.40)	0.024 ±0.012 (0.60 ±0.30)
		3mΩ~100mΩ			0.100 ±0.016 (2.55 ±0.40)	

Product Dimensions (Cont.):

Type B: Long Side Electrode

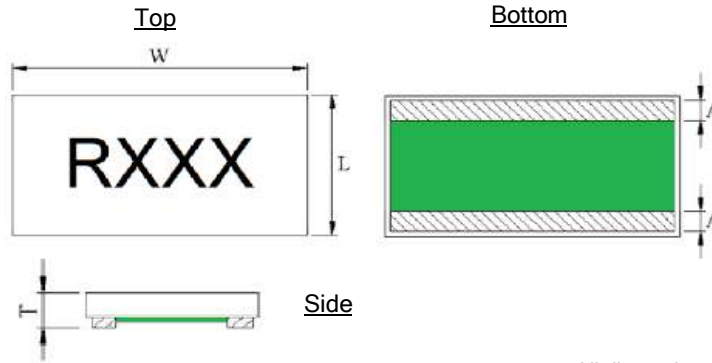

All dimensions are shown in inches, mm in parentheses.

Dimension (Metric)	Electrode Type	Resistance Range	L	W	A	T
D1WKL0508M (1220)	B	1mΩ~100mΩ	0.049 ±0.008 (1.25 ±0.20)	0.079 ±0.008 (2.00 ±0.20)	0.011 ±0.008 (0.28 ±0.20)	0.024 ±0.008 (0.60 ±0.20)
D1WKL0612M (1632)	B	1mΩ	0.063 ±0.008 (1.60 ±0.20)	0.126 ±0.008 (3.20 ±0.20)	0.016 ±0.012 (0.40 ±0.30)	0.024 ±0.008 (0.60 ±0.20)
		2mΩ~100mΩ			0.010 ±0.008 (0.25 ±0.20)	
D1WKL0815M (2040)	B	1mΩ~100mΩ	0.083 ±0.008 (2.10 ±0.20)	0.146 ±0.008 (3.70 ±0.20)	0.018 ±0.008 (0.46 ±0.20)	0.024 ±0.008 (0.60 ±0.20)
D1WKL1020M (2550)	B	1mΩ~100mΩ	0.098 ±0.008 (2.50 ±0.20)	0.197 ±0.008 (5.00 ±0.20)	0.020 ±0.008 (0.50 ±0.20)	0.024 ±0.008 (0.60 ±0.20)
D1WKL1225M (3264)	B	1mΩ~100mΩ	0.122 ±0.012 (3.10 ±0.30)	0.248 ±0.012 (6.30 ±0.30)	0.018 ±0.008 (0.45 ±0.20)	0.024 ±0.008 (0.60 ±0.20)
D1WKL0830M (2276)	B	1mΩ~100mΩ	0.098 ±0.012 (2.50 ±0.30)	0.295 ±0.012 (7.50 ±0.30)	0.022 ±0.012 (0.53 ±0.30)	0.024 ±0.008 (0.60 ±0.20)
D1WKL1530M (3876)	B	1mΩ~100mΩ	0.150 ±0.012 (3.80 ±0.30)	0.299 ±0.012 (7.60 ±0.30)	0.022 ±0.012 (0.55 ±0.30)	0.024 ±0.008 (0.60 ±0.20)
D1WKL1836M (4590)	B	1mΩ~100mΩ	0.177 ±0.012 (4.50 ±0.30)	0.354 ±0.012 (9.00 ±0.30)	0.026 ±0.012 (0.65 ±0.30)	0.024 ±0.008 (0.60 ±0.20)
D1WKL2043M (05110)	B	1mΩ~100mΩ	0.197 ±0.012 (5.00 ±0.30)	0.433 ±0.016 (11.0 ±0.40)	0.030 ±0.012 (0.75 ±0.30)	0.024 ±0.008 (0.60 ±0.20)

Electrical Specifications:

Type	D1WKL0603		D1WKL0805		D1WKL1206	
Electrode Style	Type "A" - Short Side Electrode					
Metric Size	1608		2012		3216	
Power Rating	1/2W		3/4W		1W	
Resistance Tolerance % (code)	±0.5(D)	-	10mΩ~100mΩ	-	10mΩ~500mΩ	10mΩ~700mΩ
	±1.0(F)	5mΩ~9mΩ		3mΩ~9mΩ		3mΩ~9mΩ
Resistance Offering	1mΩ steps					
TCR ppm/°C	±100	±50	±100	±50	±100	±50
Operating Temp. Range	-55°C~+155°C					
Rated Voltage	$\sqrt{\text{Power} \times \text{Resistance}}$					
Packaging (code)	5,000 pcs/reel (-T5)					

Electrical Specifications (Cont.):

Type	D1WKL2010		D1WKL2512		D1WKL4320		D1WKL4527		
Electrode Style	Type "A" - Short Side Electrode								
Metric Size	5025		6432		11050		11470		
Power Rating	1.5W		2W		3W		4W		
Resistance Tolerance % (code)	±0.5(D)	-	10mΩ~700mΩ	-	10mΩ~700mΩ	-	10mΩ~100mΩ	-	10mΩ~100mΩ
	±1.0(F)	2mΩ~9mΩ		2mΩ~9mΩ		2mΩ~9mΩ		2mΩ~9mΩ	
Resistance Offering	1mΩ steps								
TCR ppm/°C	±100	±50	±100	±50	±100	±50	±100	±50	
Operating Temp. Range	-55°C~+155°C								
Rated Voltage	$\sqrt{(\text{Power} \times \text{Resistance})}$								
Packaging (code)	4,000 pcs/reel (-T4)				2,000 pcs/reel (-T2)		1,000 pcs/reel (-T1)		

Type	D1WKL0508		D1WKL0612		D1WKL0815		D1WKL1020		D1WKL1225		
Electrode Style	Type "B" - Long Side Electrode										
Metric Size	1220		1632		2040		2550		3264		
Power Rating	1W		1.5W		2W		3W				
Resistance Tolerance % (code)	±0.5(D)	-	10mΩ~100mΩ	-	10mΩ~100mΩ	-	10mΩ~100mΩ	-	10mΩ~100mΩ	-	10mΩ~100mΩ
	±1.0(F)	1mΩ~9mΩ		1mΩ~9mΩ		1mΩ~9mΩ		1mΩ~9mΩ		1mΩ~9mΩ	
Resistance Offering	1mΩ steps										
TCR ppm/°C	±100	±50	±100	±50	±100	±50	±100	±50	±100	±50	
Operating Temp. Range	-55°C~+155°C										
Rated Voltage	$\sqrt{(\text{Power} \times \text{Resistance})}$										
Packaging (code)	5,000 pcs/reel (-T5)					4,000 pcs/reel (-T4)					

Type	D1WKL0830		D1WKL1530		D1WKL1836		D1WKL2043		
Electrode Style	Type "B" - Long Side Electrode								
Metric Size	2276		3876		4590		05110		
Power Rating	3W		4W		5W				
Resistance Tolerance % (code)	±0.5(D)	-	10mΩ~100mΩ	-	10mΩ~100mΩ	-	10mΩ~100mΩ	-	10mΩ~100mΩ
	±1.0(F)	1mΩ~9mΩ		1mΩ~9mΩ		1mΩ~9mΩ		1mΩ~9mΩ	
Resistance Offering	1mΩ steps								
TCR ppm/°C	±100	±50	±100	±50	±100	±50	±100	±50	
Operating Temp. Range	-55°C~+155°C								
Rated Voltage	$\sqrt{(\text{Power} \times \text{Resistance})}$								
Packaging (code)	4,000 pcs/reel (-T4)			2,000 pcs/reel (-T2)					

Power Derating Curve:

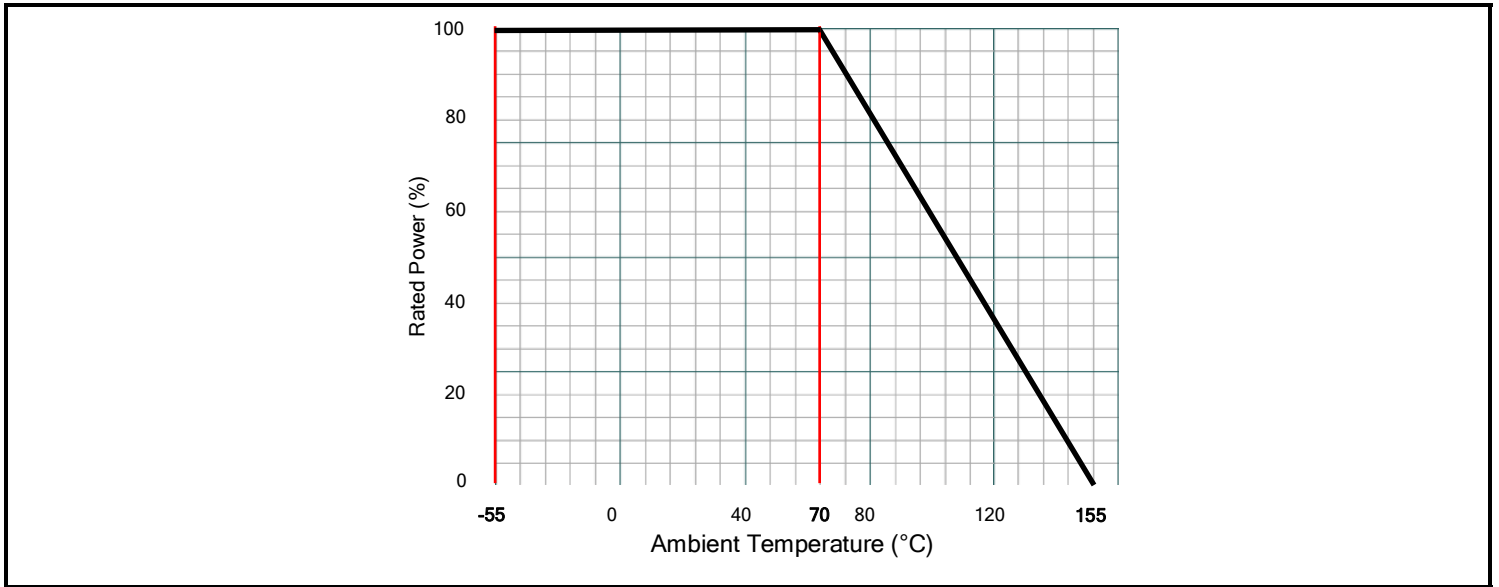

Reliability Specifications:

Test	Procedure	Specification
Short Time Overload IEC60115-1 4.13	P = 2.5PR; T = 25 ±2°C, t = 5 seconds	±(1.0%+0.5mΩ)
Load Life IEC60115-1 4.25	T = 70°C ±2°C Vtest = Vmax; t = 90 mins "ON" and 30 mins "OFF" Test period: 1,000 hours	±(2.0%+0.5mΩ)
Temperature Cycle (Thermal Shock) IEC60115-1 4.19	Repeat 100 cycles as follows: -55 ±3°C (30 min.) / +155 ±3°C (30 min.)	±(1.0%+0.5mΩ)
Resistance To Solder Heat IEC60115-1 4.18	Through Reflow, parts are subjected to 3 reflow cycles	±(1.0%+0.5mΩ)
Mechanical Shock IEC60115-1 4.21	A = 100G, t = 6ms	±(1.0%+0.5mΩ)
High Temperature Exposure IEC60115-1 4.25	T = +155 ±2°C; t = 1000h	±(1.0%+0.5mΩ)
Low Temperature Storage IEC60115-1 4.25	T = -55 ±2°C; t = 1000h	±(1.0%+0.5mΩ)
Moisture Load Life IEC60115-1 4.25	Vtest = Vmax; T = 60 ±2°C; RH = 95%; t = 90 mins "ON", 30 mins "OFF", 1000h	±(2.0%+0.5mΩ)
Solderability IEC60115-1 4.17	Dip into solder at T = 245 ±5°C, t = 3 ±1 second	The covered area >95%
Substrate Bending IEC60115-1 4.33	Span between fulcrums: 90mm, Bend Width: 2mm Test Board: Glass-epoxy board Thickness = 1.6mm	±(1.0%+0.5mΩ)

Paper Tape Dimensions:

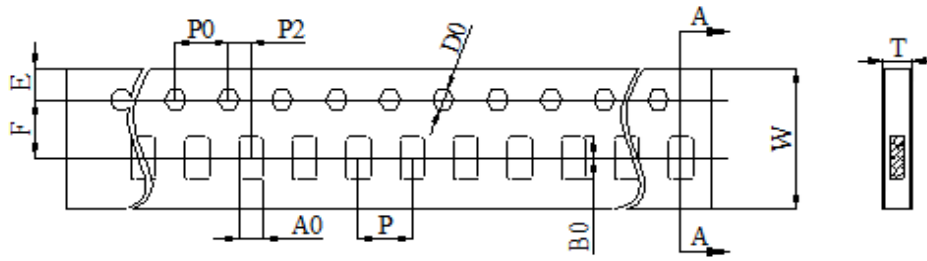

All dimensions in mm.

Size	W	P0	P	P2	A0	B0	D0	F	E	T
0603	8.00 ±0.30	4.00 ±0.10	4.00 ±0.10	2.00 ±0.10	0.98 ±0.10	1.85 ±0.10	1.50 ±0.10	3.50 ±0.10	1.75 ±0.10	0.75 ±0.10
0805	8.00 ±0.30	4.00 ±0.10	4.00 ±0.10	2.00 ±0.10	1.55 ±0.10	2.30 ±0.10	1.50 ±0.10	3.50 ±0.10	1.75 ±0.10	0.75 ±0.10
1206	8.00 ±0.30	4.00 ±0.10	4.00 ±0.10	2.00 ±0.10	1.90 ±0.20	3.50 ±0.20	1.50 ±0.10	3.50 ±0.10	1.75 ±0.10	0.75 ±0.10
0508	8.00 ±0.30	4.00 ±0.10	4.00 ±0.10	2.00 ±0.10	1.55 ±0.10	2.30 ±0.10	1.50 ±0.10	3.50 ±0.10	1.75 ±0.10	0.75 ±0.10
0612	8.00 ±0.30	4.00 ±0.10	4.00 ±0.10	2.00 ±0.10	1.90 ±0.20	3.50 ±0.20	1.50 ±0.10	3.50 ±0.10	1.75 ±0.10	0.75 ±0.10

Plastic Tape Dimensions:

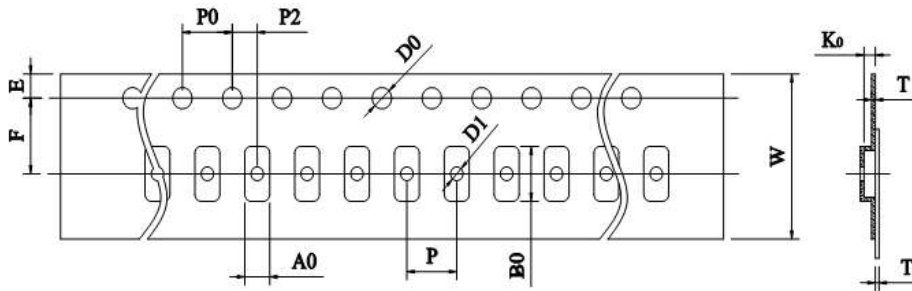

All dimensions in mm.

Size	W	P0	P	P2	A0	B0	D0	F	E	T	T1	K0
2010	12.0 ±0.30	4.00 ±0.10	4.00 ±0.10	2.00 ±0.10	2.85 ±0.20	5.45 ±0.20	1.50 ±0.10	5.50 ±0.10	1.75 ±0.10	0.25 ±0.10	Max 0.10	0.80 ±0.20
2512	12.0 ±0.30	4.00 ±0.10	4.00 ±0.10	2.00 ±0.10	3.40 ±0.20	6.75 ±0.20	1.50 ±0.10	5.50 ±0.10	1.75 ±0.10	0.25 ±0.10	Max 0.10	1.00 ±0.20
4320	24.0 ±0.30	4.00 ±0.10	8.00 ±0.10	2.00 ±0.10	5.50 ±0.20	11.5 ±0.20	1.50 ±0.10	11.5 ±0.10	1.75 ±0.10	0.30 ±0.10	Max 0.10	0.90 ±0.20
4527	24.0 ±0.30	4.00 ±0.10	12.0 ±0.10	2.00 ±0.10	7.50 ±0.20	12.0 ±0.20	1.50 ±0.10	11.5 ±0.10	1.75 ±0.10	0.30 ±0.10	Max 0.10	0.90 ±0.20
0815	12.0 ±0.40	4.00 ±0.10	4.00 ±0.10	2.00 ±0.10	2.30 ±0.20	4.10 ±0.20	1.50 ±0.10	5.50 ±0.10	1.75 ±0.10	0.25 ±0.10	Max 0.10	0.75 ±0.20
1020	12.0 ±0.30	4.00 ±0.10	4.00 ±0.10	2.00 ±0.10	2.85 ±0.20	5.45 ±0.20	1.50 ±0.10	5.50 ±0.10	1.75 ±0.10	0.25 ±0.10	Max 0.10	0.80 ±0.20
1225	12.0 ±0.30	4.00 ±0.10	4.00 ±0.10	2.00 ±0.10	3.40 ±0.20	6.75 ±0.20	1.50 ±0.10	5.50 ±0.10	1.75 ±0.10	0.25 ±0.10	Max 0.10	1.00 ±0.20
0830	16.0 ±0.30	4.00 ±0.10	4.00 ±0.10	2.00 ±0.10	2.80 ±0.20	8.00 ±0.20	1.50 ±0.10	7.50 ±0.10	1.75 ±0.10	0.30 ±0.10	Max 0.10	0.80 ±0.20
1530	16.0 ±0.30	4.00 ±0.10	8.00 ±0.10	2.00 ±0.10	4.15 ±0.20	7.95 ±0.20	1.50 ±0.10	7.50 ±0.10	1.75 ±0.10	0.30 ±0.10	Max 0.10	0.90 ±0.20
1836	16.0 ±0.30	4.00 ±0.10	8.00 ±0.10	2.00 ±0.10	4.85 ±0.20	9.35 ±0.20	1.50 ±0.10	7.50 ±0.10	1.75 ±0.10	0.30 ±0.10	Max 0.10	0.90 ±0.20
2043	24.0 ±0.30	4.00 ±0.10	8.00 ±0.10	2.00 ±0.10	5.50 ±0.20	11.5 ±0.20	1.50 ±0.10	11.5 ±0.10	1.75 ±0.10	0.30 ±0.10	Max 0.10	0.90 ±0.20

Reel Dimensions:

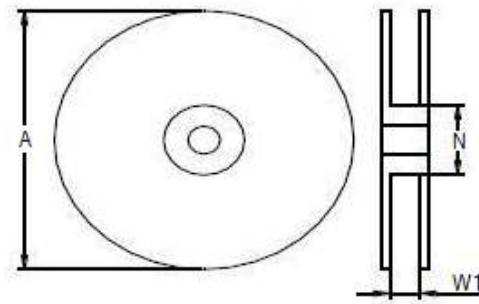

All dimensions in mm.

Size	0603	0805	1206	2010	2512	4320	4527	0508	0612	0815	1020	1225	0830	1530	1836	2043
A	178 ±5.00	178 ±5.00	178 ±5.00	178 ±5.00	178 ±5.00	178 ±5.00	178 ±5.00	178 ±5.00	178 ±5.00	178 ±5.00	178 ±5.00	178 ±5.00	178 ±5.00	178 ±5.00	178 ±5.00	178 ±5.00
N	60.0 ±2.00	60.0 ±2.00	60.0 ±2.00	60.0 ±2.00	60.0 ±2.00	60.0 ±2.00	60.0 ±2.00	60.0 ±2.00	60.0 ±2.00	60.0 ±2.00	60.0 ±2.00	60.0 ±2.00	60.0 ±2.00	60.0 ±2.00	60.0 ±2.00	60.0 ±2.00
W1	9.00 ±1.00	9.00 ±1.00	9.00 ±1.00	13.0 ±1.00	13.0 ±1.00	24.5 ±1.00	24.5 ±1.00	9.00 ±1.00	9.00 ±1.00	13.0 ±1.00	13.0 ±1.00	13.0 ±1.00	17.0 ±1.00	17.0 ±1.00	17.0 ±1.00	24.5 ±1.00

Recommended Land Pattern:

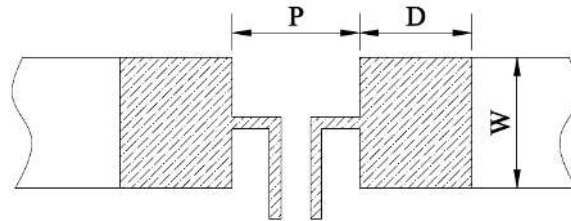

All dimensions in mm.

Size	Electrode Type	Resistance Range	P	W	D
D1WKL0603	A	5mΩ	0.50	0.92	1.35
		6mΩ~100mΩ	0.60		1.30
D1WKL0805	A	3mΩ	0.50	1.44	1.55
		4mΩ~500mΩ	0.80		1.40
D1WKL1206	A	3mΩ	0.60	1.84	2.10
		4mΩ~700mΩ	1.20		1.80
D1WKL2010	A	2mΩ	0.70	2.88	3.65
		3mΩ			2.65
		4mΩ~700mΩ	2.70		2.65
D1WKL2512	A	2mΩ	0.60	3.57	4.35
		3mΩ	0.90		4.20
		4mΩ~700mΩ	3.10		3.10
D1WKL4320	A	2mΩ	1.10	5.75	6.43
		3mΩ	1.70		6.15
		4mΩ~8mΩ	5.00		
		9mΩ~100mΩ			4.50
D1WKL4527	A	2mΩ	1.20	8.05	6.65
		3mΩ~100mΩ	5.20		4.65

Recommended Land Pattern (Cont.):

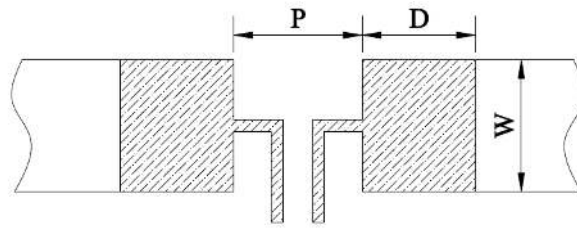

All dimensions in mm.

Size	Electrode Type	Resistance Range	P	W	D
D1WKL0508	B	1mΩ~100mΩ	0.60	2.30	1.10
D1WKL0612	B	1mΩ	0.50	3.68	1.35
		2mΩ~100mΩ	0.60		1.30
D1WKL0815	B	1mΩ~100mΩ	0.70	4.26	1.45
D1WKL1020	B	1mΩ~100mΩ	1.00	5.75	2.25
D1WKL1225	B	1mΩ~100mΩ	1.40	7.25	2.35
D1WKL0830	B	1mΩ~100mΩ	0.95	8.63	2.28
D1WKL1530	B	1mΩ~100mΩ	1.70	8.74	2.55
D1WKL1836	B	1mΩ~100mΩ	2.10	10.35	2.70
D1WKL2043	B	1mΩ~100mΩ	2.40	12.65	2.80

Soldering Profile:

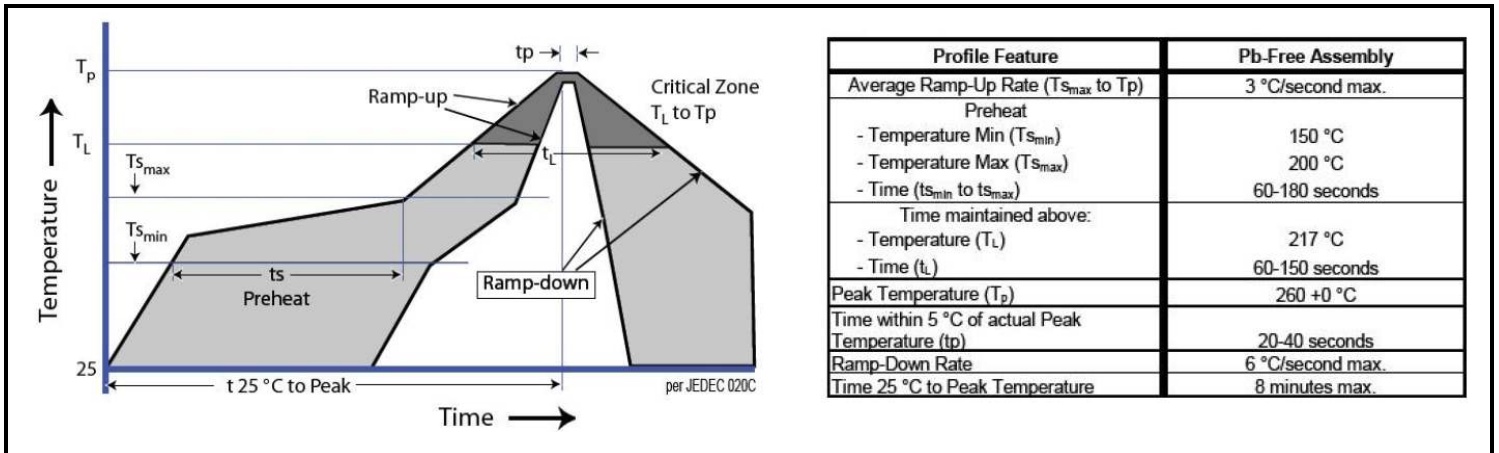

Storage Conditions:

Environment Conditions:

Products should be stored under the following environmental conditions.

- Temperature: +5 to +35°C
- Humidity: 45 to 85% relative humidity
- Do not keep products in environments where they may be subject to particulate contamination or harmful gases such as sulfuric acid or hydrogen chloride as it may cause oxidization on electrodes, resulting in poor solderability.
- Products should be stored in a space that does not expose it to high temperatures, vibration, or direct sunlight.
- Products should be stored in the original airtight packaging until use.