

1. Mechanical Dimensions:

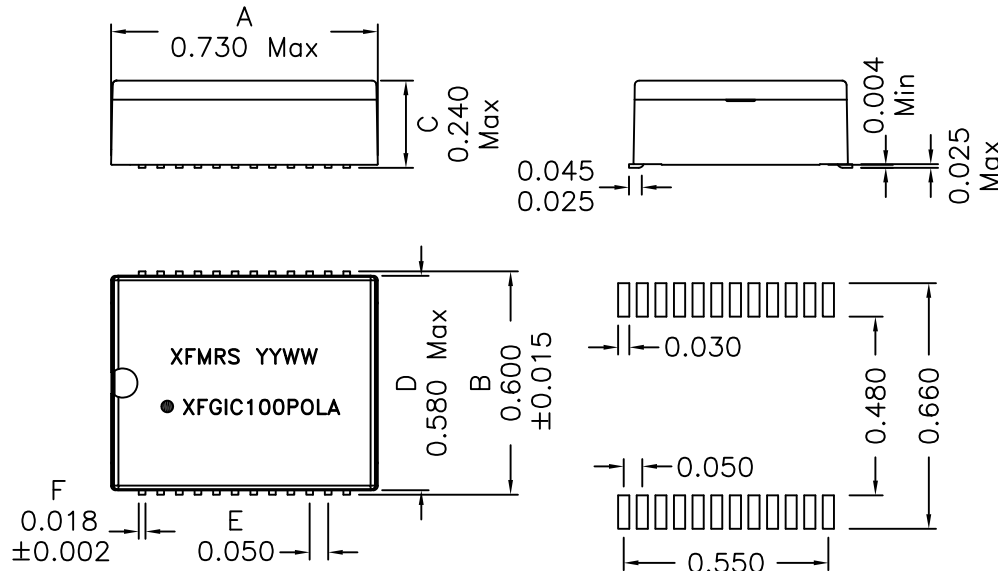

SUGGESTED PAD LAYOUT

2. Schematic:

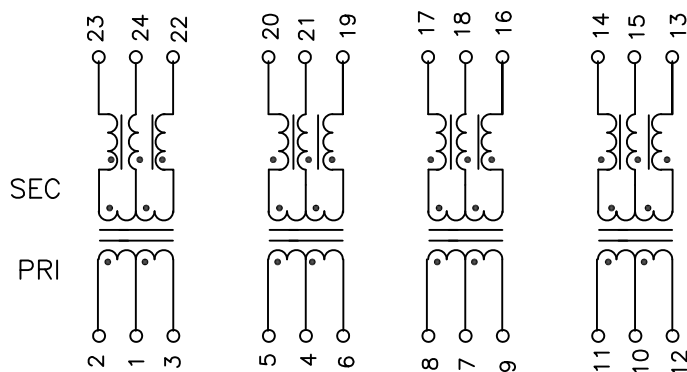

3. Electrical Specifications: @25°C

ISOLATION: 1500Vrms
 TURNS RATIO: (PRI/SEC) 1CT:1CT ±2%
 SEC OCL: 350uH Min @100KHz 100mV, 15mAdc
 Rise Time: 1.75ns Max.

INSERTION LOSS: -1.0dB MAX @1MHz-80MHz
 -1.1dB MAX @80-100MHz
 -1.5dB MAX @100-125MHz

RETURN LOSS: 18dB Typ @1-10MHz
 15dB Typ @30MHz
 12dB Typ @80MHz
 10dB Typ @100MHz

Common to Common Rejection:
 -60dB Min @1MHz
 -40dB Min @30MHz
 -35dB Min @80MHz
 -30dB Min @100MHz

CMRR: -30dB Min @1-60MHz
 Crosstalk: -40dB Min @1-30MHz
 -30dB Min @100MHz

Rated Current: 1200mA Max for 200mS
 @57Vdc Thru Each Sec CT
 Rated Current: 720mA Max Continuous
 @57Vdc Thru Each Sec CT

Q: tbd Min @10KHz 50mV

Notes:

1. Solderability: Leads shall meet MIL-STD-202G, Method 208H for solderability.
2. Flammability: UL94V-0
3. ASTM oxygen index: > 28%
4. Insulation System: Class H 180°C. UL file E151556
5. Operating Temperature Range: All listed parameters are to be within tolerance from -40°C to +85°C
6. Storage Temperature Range: -55°C to +125°C
7. Aqueous wash compatible
8. SMD Lead Coplanarity: ±0.004"(0.102mm)
9. Electrical and mechanical specifications 100% tested
10. RoHS Compliant Component
11. 802.3AT Compliant.
12. Recommended IR Reflow peak temp of 250C Max.

PRELIMINARY

DOC. REV: A/-

XFMRs Inc www.XFMRs.com		Title: 1000BASE-T Modules	
UNLESS OTHERWISE SPECIFIED TOLERANCES: .xxx ±0.010 Dimensions in Inch	P/N: XFGIC100POLA		REV. B
	DWN.	Yuan	Feb-15-16
SHEET 1 OF 1	CHK.	YK Liao	Feb-15-16
	APP.	GL	Feb-15-16

PROPRIETARY

Document is the property of XFMRs Group & is not allowed to be duplicated without authorization.