

XL60 Supercapacitors

Cylindrical cells



Description

Eaton supercapacitors are unique, ultra-high capacitance devices utilizing electric double layer capacitor (EDLC) construction combined with new, high performance materials. This combination of advanced technologies allows Eaton to offer a wide variety of capacitor solutions tailored to specific applications. The XL60 supercapacitor cells offers high energy and power in a standardized form factor. Terminal design is optimized for high reliability and low contact resistance.

Features and benefits

- Long life energy storage, up to 20 years*
- Ultra low ESR for very high power density
- Wide operating temperature range
- Maintenance free
- Cost effective backup power and large energy recapture
- Low operating costs
- High efficiency (>98%) under broad environmental conditions
- High reliability, green solution
- UL recognized (3000 F/2.7 V)

Applications

- Backup power
- Peak power shaving, pulse power
- Engine starting
- Energy capture and re-use (Hybrids) for automotive, trucks, mining and construction, equipment, cranes
- Remote power for sensors, LEDs, switches

* Supercapacitor lifetimes vary based on charge voltage and temperature. See Eaton's application guidelines or contact your local Eaton sales representative for more information on lifetime estimates

Ratings¹⁰

Capacitance	3000 F to 3400 F
Maximum working voltage	2.70 V / 2.85 V / 3.00 V
Surge voltage	2.85 V / 3.00 V / 3.20 V
Capacitance tolerance	0% to +20%
Operating temperature range	-40 °C to +65 °C
Extended operating temperature range	-40 °C to +85 °C (with voltage derating to 2.3 V / 2.4 V / na V @ +85 °C)

Specifications

Capacitance ¹ (F)	Part number	Maximum working voltage (V)	Maximum initial ESR ¹ (mΩ)	Nominal leakage current ² (mA)	Stored energy ³ (Wh)	Peak power ⁴ (W)	Pulse current ⁵ (A)	Continuous current ⁶ (A)	Typical thermal resistance ⁷ Rth (°C/W)	Short circuit current ⁸ (A)
3000	XL60-2R7308W-R	2.70	0.23	5.0	3.0	7,900	2,400	143	3.2	11,700
3000	XL60-2R7308T-R	2.70	0.23	5.0	3.0	7,900	2,400	143	3.2	11,700
3400	XL60-2R9348W-R	2.85	0.23	8.0	3.8	8,800	2,700	143	3.2	12,400
3400	XL60-2R9348T-R	2.85	0.23	8.0	3.8	8,800	2,700	143	3.2	12,400
3000	XL60-3R0308W-R	3.00	0.23	7.0	3.8	9,700	2,400	143	3.2	13,000
3000	XL60-3R0308T-R	3.00	0.23	7.0	3.8	9,700	2,400	143	3.2	13,000

Performance

Parameter	Capacitance change (% of initial value)	ESR (% of initial maximum value)
Lifetime — 1,500 hours at maximum rated voltage and operating temperature	≤ 20%	≤ 200%
Lifetime — 1,000 hours at maximum rated voltage and operating temperature (3.0 V/3000 F)	≤ 20%	≤ 200%
Charge/discharge cycling ⁹ — 1 million at +25 °C	≤ 20%	≤ 200%
Storage, uncharged, up to +35 °C — 3 years	≤ 5%	≤ 10%

1. Capacitance, Equivalent series resistance (ESR) and leakage current are measured according to IEC62391-1 with current in milliamps (mA) = $8 \times C \times V$.

2. Leakage current at +20 °C after 72 hour charge and hold.

3. Stored energy (Wh) = $\frac{0.5 \times C \times V^2}{3600}$

4. Peak power (W) = $\frac{V^2}{4 \times \text{ESR}}$

5. Pulse current for 1 second from full rate voltage to half voltage. (A) = $\frac{0.5 \times V \times C}{(1 + \text{ESR} \times C)}$

6. Continuous current with a 15 °C temperature rise. Continuous current (A) = $\sqrt{\frac{15}{\text{ESR} \times R_{th}}}$

7. Thermal resistance (Rth) cell body temperature to ambient in open air in degrees C per Watt (°C/W).

8. Short circuit current is for safety information only. Do not use as operating current.

9. Cycling between maximum working voltage and half voltage with 3 seconds rest at +25 °C, 100 A.

10. Testing and verification of product under end application conditions is recommended

Safety and certifications

Agency information	UL Recognized (3000 F/2.7 V), Guide BBBG2, File MH46887
Shock and vibration	IEC 61373 Category 1, Class B, IEC 60068-2-6
Safety	UL 810A
Environmental	RoHS compliant, lead free, halogen free
Altitude, Operating	10,000 ft
Altitude, Non-operating	40,000 ft

Dimensions (mm)

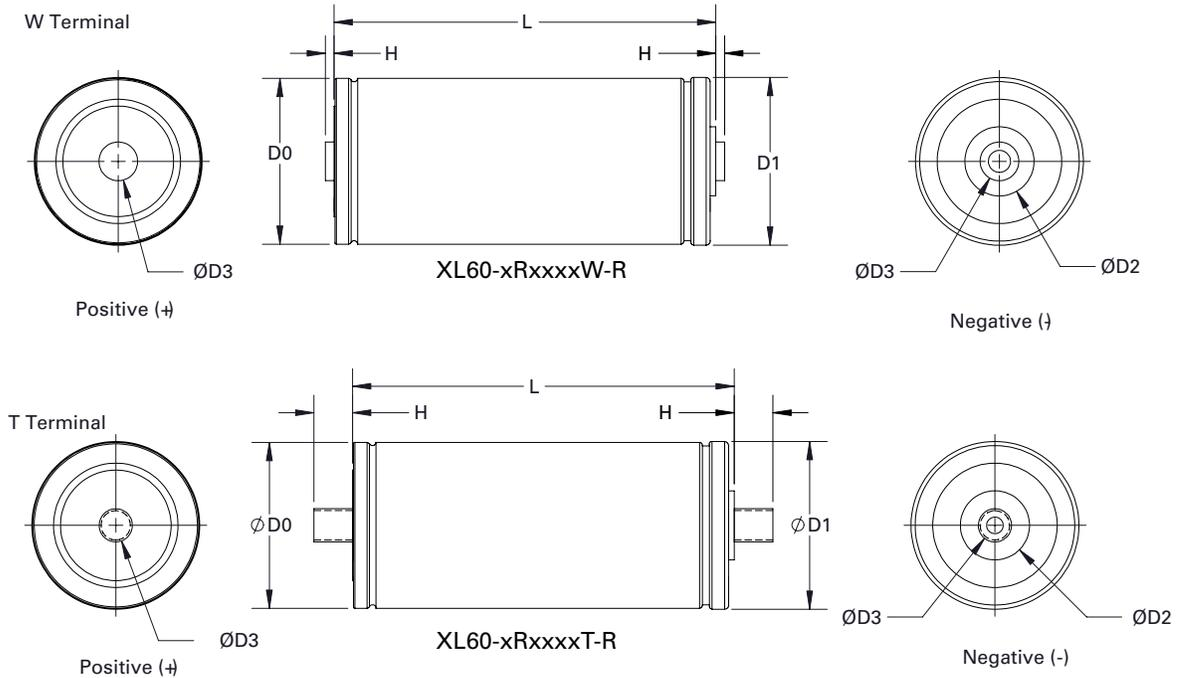

Part number	D0 (±0.3)	D1 (±0.7)	D2 (±0.1)	D3 (±0.1)	H (±0.125)	L (±0.5)	Typical mass (g)
XL60-xRxxxxW-R	60.3	60.7	25.0	Ø14.0	3.18	138.0	525
XL60-xRxxxxT-R	60.3	60.7	25.0	M12, P1.75	14.0	138.0	515

Part numbering system

XL	60	-2R7	30	8	-R
Family code	Size reference (mm)	Voltage (V) R = decimal	Capacitance (µF) Value	Multiplier	Standard product
XL = Family Code	Diameter = 60	2R7 = 2.7 V	Example 308 = 30 x 10 ⁸ µF or 3,000 F		

Packaging information

- Standard packaging: Bulk, 20 parts per box

Part Marking

- Manufacturer
- Capacitance (F)
- Maximum working voltage (V)
- Family code or part number
- Polarity

Life Support Policy: Eaton does not authorize the use of any of its products for use in life support devices or systems without the express written approval of an officer of the Company. Life support systems are devices which support or sustain life, and whose failure to perform, when properly used in accordance with instructions for use provided in the labeling, can be reasonably expected to result in significant injury to the user.

Eaton reserves the right, without notice, to change design or construction of any products and to discontinue or limit distribution of any products. Eaton also reserves the right to change or update, without notice, any technical information contained in this bulletin.

Eaton
Electronics Division
1000 Eaton Boulevard
Cleveland, OH 44122
United States
Eaton.com/electronics

© 2020 Eaton
All Rights Reserved
Printed in USA
Publication No. 10339
July 2020

Eaton is a registered trademark.

All other trademarks are property of their respective owners.

Follow us on social media to get the latest product and support information.

