

DESIGNED & DIMENSIONED  
IN MILLIMETERS [INCHES]

FT5-XX-XX.X-X-DV-XX-X-TR

DO NOT  
SCALE FROM  
THIS PRINT

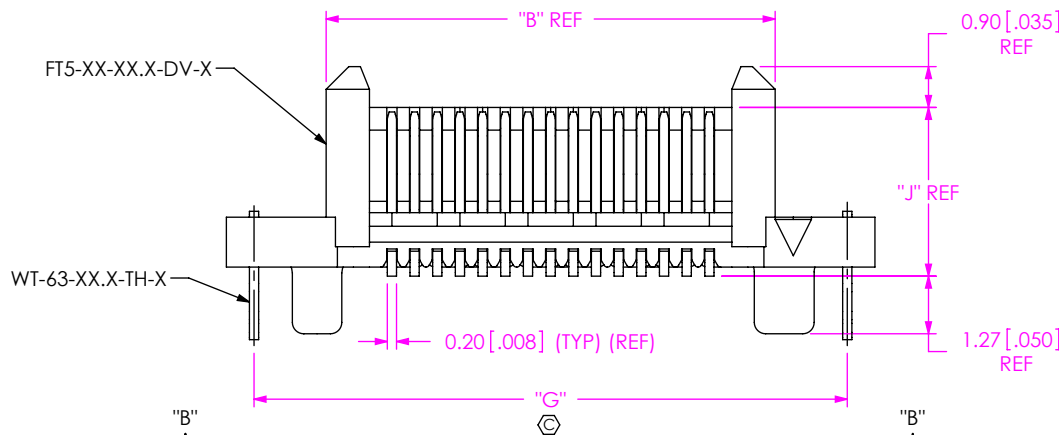
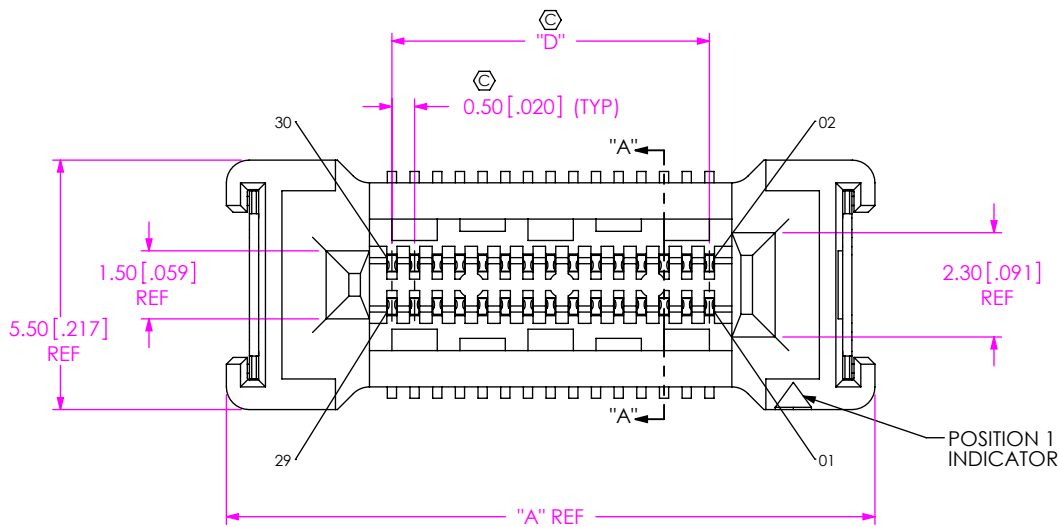

No. OF POSITIONS  
-15, -30  
(PER ROW)

PACKAGING  
-TR: TAPE & REEL  
(SEE NOTES 3, 4 & 5)

LEAD STYLE  
\*\*-01.0: 1MM  
\*\*-03.0: 3MM  
\*-06.0: 6MM  
\*-08.0: 8MM  
\*-10.0: 10MM

OPTION  
-P: PICK AND PLACE PAD  
(USE PPP-71)  
(SEE FIG. 4, SHT 3)

PLATING SPECIFICATION  
-L: LIGHT GOLD ON CONTACT  
AREA, MATTE TIN ON TAIL  
(USE T-1M84-XX.X-L)

WELD TAB  
-TH: THRU HOLE  
(USE WT-63-XX.X-TH-X)  
\*-SM: SURFACE MOUNT  
(USE WT-63-XX.X-SM-X)

ROW SPECIFICATION  
-DV: DOUBLE VERTICAL

(\* = NOT TOOLED)  
\*\* = -P OPTION MANDATORY.  
NOT MANDATORY FOR EXISTING CUSTOMERS ONLY

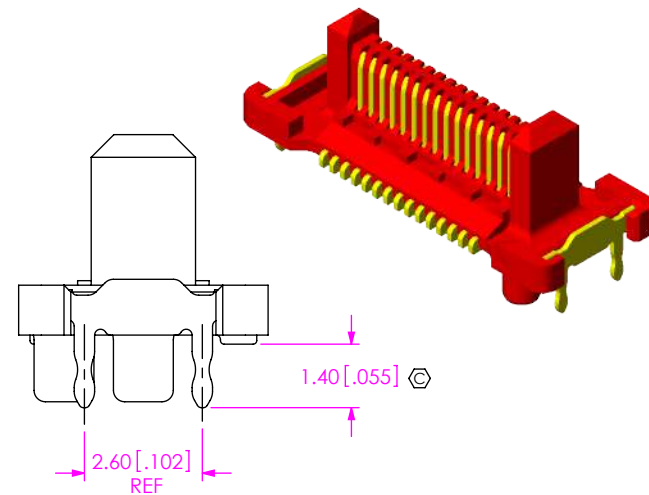

NOTES:

1. Ⓢ REPRESENTS A CRITICAL DIMENSION.
2. PUSH OUT FORCE 1.80N [0.40LBS].
3. TAPE & REEL WILL BE SUPPLIED WHETHER OR NOT -TR IS SPECIFIED.
4. FOR QUANTITIES UP TO 49 PCS., NO LEADER, TRAILER OR EIA-481 REEL WILL BE SUPPLIED.
5. FOR QUANTITIES OF 50 TO 124 PCS., NO LEADER, TRAILER OR EIA-481 REEL WILL BE SUPPLIED.

FIG 1  
FT5-15-01.0-X-DV-TH-X-TR SHOWN

LEAD STYLE	BODY PART NUMBER	TERMINAL PART NUMBER	WT PART NUMBER	SPACER BODY PART NUMBER
-01.0	FT5-XX-01.0-X-DV-X	T-1M84-01.0-X	WT-63-01.0-XX-X	N/A
-03.0	FT5-XX-03.0-X-DV-X	T-1M84-03.0-X	WT-63-03.0-XX-X	N/A
*-06.0	FT5-XX-03.0-X-DV-X	T-1M84-06.0-X	WT-63-06.0-XX-X	TFHH-XX-03.0-X
*-08.0	FT5-XX-03.0-X-DV-X	T-1M84-08.0-X	WT-63-08.0-XX-X	TFHH-XX-05.0-X
*-10.0	FT5-XX-03.0-X-DV-X	T-1M84-10.0-X	WT-63-10.0-XX-X	TFHH-XX-07.0-X

(\* = NOT TOOLED)

FS5 LEAD STYLE	FT5 LEAD STYLE				
	-01.0	-03.0	*-06.0	*-08.0	*-10.0
-04.0	5.0 [0.20]	7.0 [0.28]	10.0 [0.39]	12.0 [0.47]	14.0 [0.55]

(\* = NOT TOOLED)

UNLESS OTHERWISE SPECIFIED,  
DIMENSIONS ARE IN  
MILLIMETERS [INCHES].

TOLERANCES ARE:  
DECIMALS ANGLES  
X.X: ±0.3 [0.1] 2°  
X.XX: ±0.13 [0.05]  
X.XXX: ±0.051 [0.020]

PROPRIETARY NOTE

THIS DOCUMENT CONTAINS INFORMATION  
CONFIDENTIAL AND PROPRIETARY TO  
SAMTEC, INC. AND SHALL NOT BE REPRODUCED  
OR TRANSFERRED TO OTHER DOCUMENTS OR  
DISCLOSED TO OTHERS OR USED FOR ANY  
PURPOSE OTHER THAN THAT WHICH IT WAS  
OBTAINED WITHOUT THE EXPRESSED WRITTEN  
CONSENT OF SAMTEC, INC.

MATERIAL: DO NOT SCALE DRAWING  
INSULATOR: LCP, COLOR: BLACK  
CONTACT: PHOS BRONZE  
WT: PHOS BRONZE

SHEET SCALE: 6:1



520 PARK EAST BLVD, NEW ALBANY, IN 47150  
PHONE: 812-944-6733 FAX: 812-948-5047  
e-Mail: info@SAMTEC.com code: 55322

DESCRIPTION:  
FT5 TERMINAL ASSEMBLY  
DWG. NO.  
FT5-XX-XX.X-X-DV-XX-X-TR  
BY: R MUSSER 08/04/2009 SHEET 1 OF 3

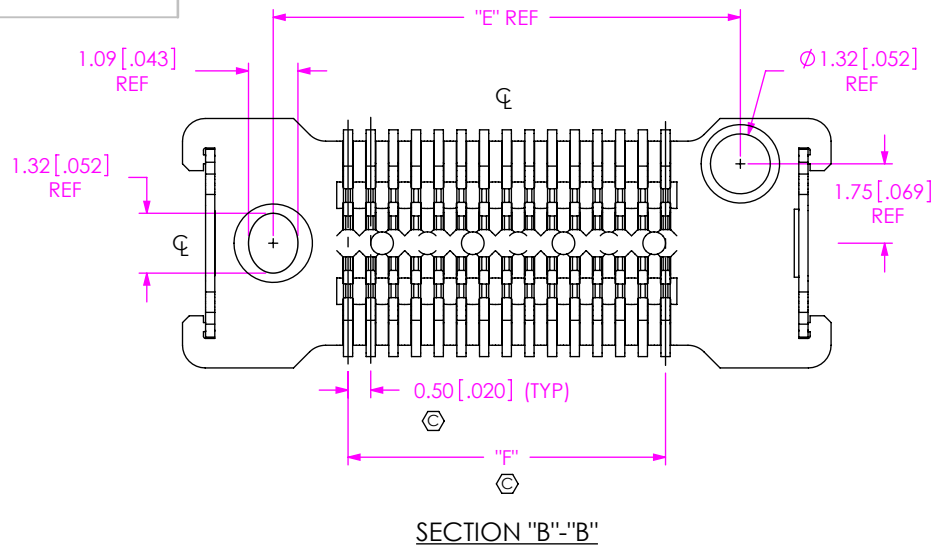

SECTION "B"-"B"

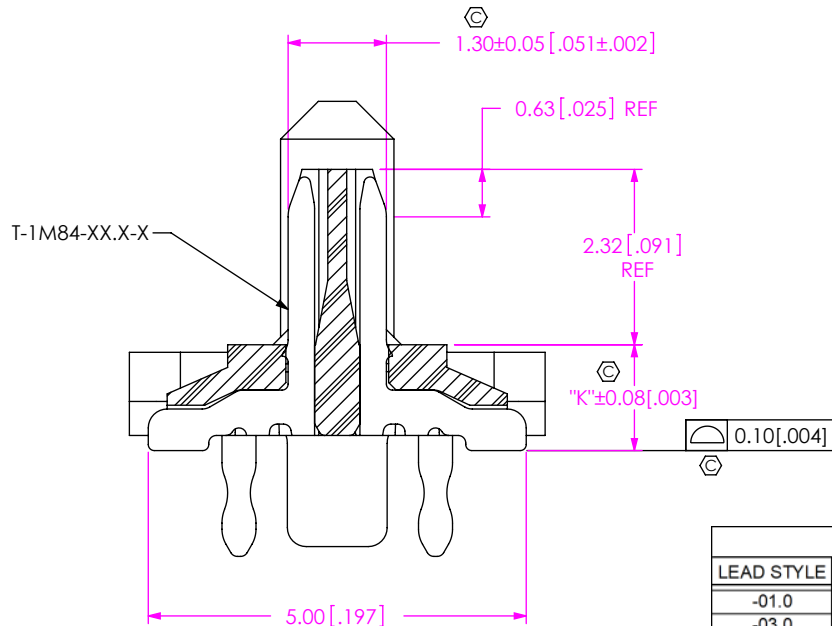

SECTION "A"-"A"  
SCALE 10:1

TABLE 4

LEAD STYLE	"J"	"K"
-01.0	3.72 [0.146]	1.40 [0.055]
-03.0	5.72 [0.225]	3.40 [0.134]
*-06.0	8.72 [0.343]	6.40 [0.252]
*-08.0	10.72 [0.422]	8.40 [0.331]
*-10.0	12.72 [0.501]	10.40 [0.409]

(\* = NOT TOOLED)

TABLE 5

No. OF POS	"A"	"B"	"D"	"E"	"F"	"G"	"H"
-15	14.30 [0.563]	9.90 [0.390]	7.000 [0.2756]	10.30 [0.406]	7.000 [0.2756]	13.08 [0.515]	15.60 [0.614]
-30	21.80 [0.858]	17.40 [0.685]	14.500 [0.5709]	17.80 [0.701]	14.500 [0.5709]	20.58 [0.810]	23.10 [0.909]

TABLE 3

TAIL	LEAD STYLE				
	-01.0	-03.0	*-06.0	*-08.0	*-10.0
-TH	WT-63-01.0-TH-X	WT-63-03.0-TH-X	WT-63-06.0-TH-X	WT-63-08.0-TH-X	WT-63-10.0-TH-X
*-SM	WT-63-01.0-SM-X	WT-63-03.0-SM-X	WT-63-06.0-SM-X	WT-63-08.0-SM-X	WT-63-10.0-SM-X

(\* = NOT TOOLED)

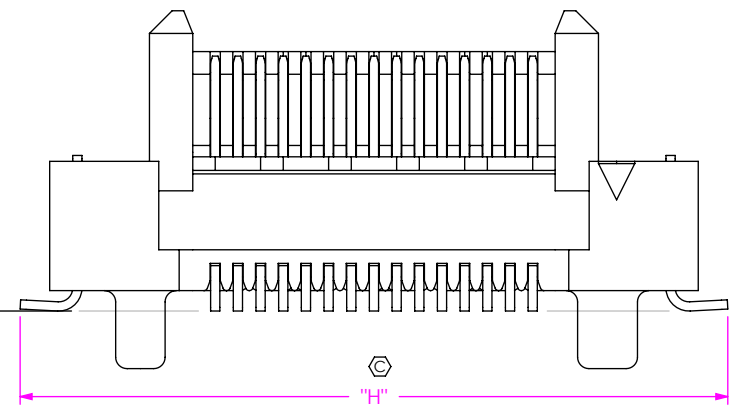
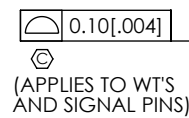
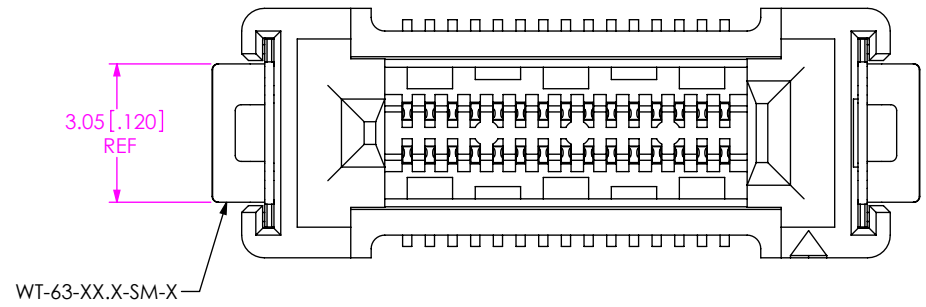

FIG 2  
-SM WELD TAB  
(FT5-15-03.0-X-DV-SM-X-TR SHOWN)  
(SAME AS FIG 1, EXCEPT AS SHOWN)  
(NOT TOOLED)

PROPRIETARY NOTE  
THIS DOCUMENT CONTAINS INFORMATION  
CONFIDENTIAL AND PROPRIETARY TO  
SAMTEC, INC. AND SHALL NOT BE REPRODUCED  
OR TRANSFERRED TO OTHER DOCUMENTS OR  
DISCLOSED TO OTHERS OR USED FOR ANY  
PURPOSE OTHER THAN THAT WHICH IT WAS  
OBTAINED WITHOUT THE EXPRESSED WRITTEN  
CONSENT OF SAMTEC, INC.

DO NOT SCALE DRAWING

SHEET SCALE: 6:1

**samtec**

520 PARK EAST BLVD, NEW ALBANY, IN 47150  
PHONE: 812-944-6733 FAX: 812-948-5047  
e-Mail: info@SAMTEC.com code: 55322

DESCRIPTION:  
FT5 TERMINAL ASSEMBLY

DWG. NO.  
FT5-XX-XX.X-X-DV-XX-X-TR

BY: R MUSSER 08/04/2009 SHEET 2 OF 3

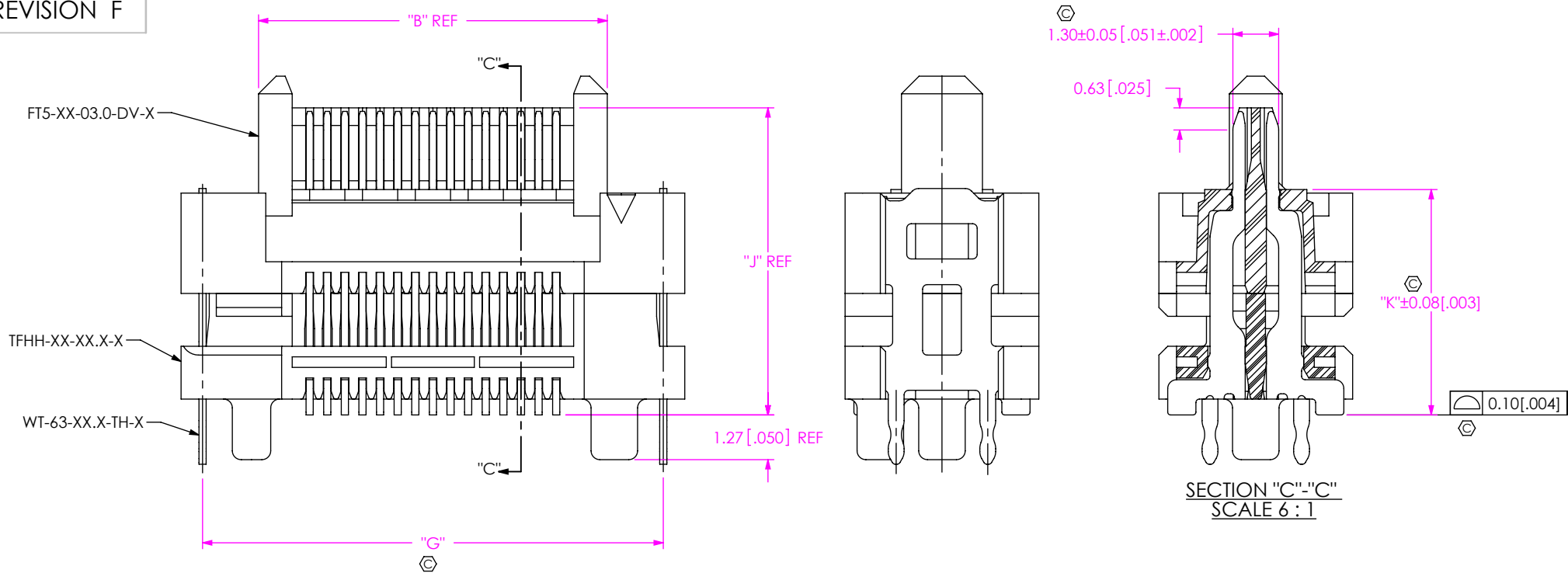

FIG 3  
-06.0 THRU -10.0 LEAD STYLES  
(FT5-15-06.0-X-DV-TH-X-TR SHOWN)  
(SAME AS FIG 1, EXCEPT AS SHOWN)  
(NOT TOOLED)

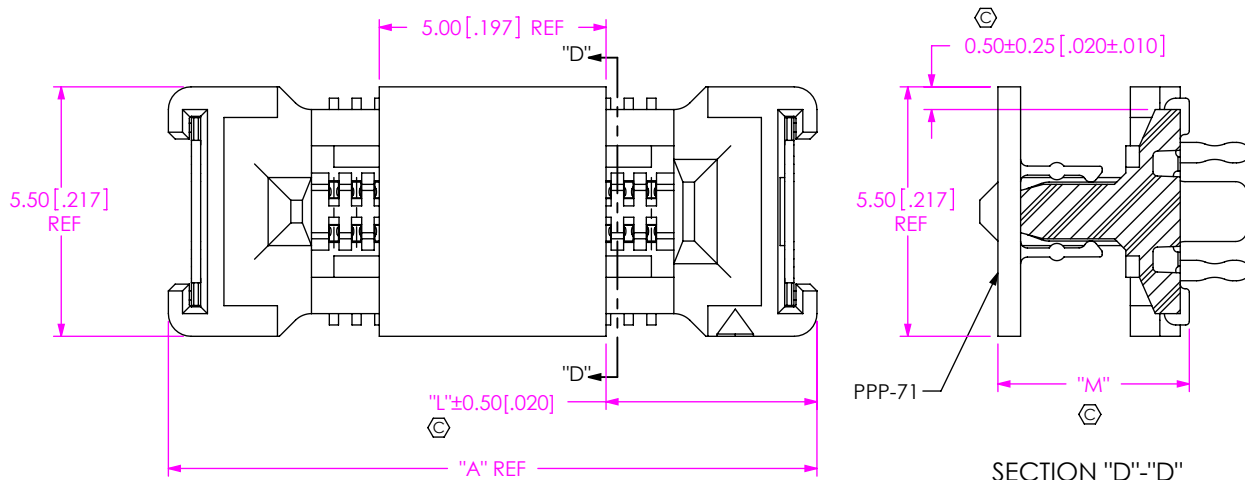

FIG 4  
-P: PICK AND PLACE PAD  
(FT5-15-01.0-X-DV-TH-P-TR SHOWN)

TABLE 6		
No. OF POS	"L"	
-15	4.65	[0.183]
-30	8.40	[0.331]

TABLE 7		
LEAD STYLE	"M"	
-01.0	4.22	[0.166]
-03.0	6.22	[0.245]
*-06.0	9.22	[0.363]
*-08.0	11.22	[0.442]
*-10.0	13.22	[0.520]

(\* = NOT TOOLED)

PROPRIETARY NOTE

THIS DOCUMENT CONTAINS INFORMATION CONFIDENTIAL AND PROPRIETARY TO SAMTEC, INC. AND SHALL NOT BE REPRODUCED OR TRANSFERRED TO OTHER DOCUMENTS OR DISCLOSED TO OTHERS OR USED FOR ANY PURPOSE OTHER THAN THAT WHICH IT WAS OBTAINED WITHOUT THE EXPRESSED WRITTEN CONSENT OF SAMTEC, INC.

DO NOT SCALE DRAWING

SHEET SCALE: 6:1

**samtec**

520 PARK EAST BLVD, NEW ALBANY, IN 47150  
PHONE: 812-944-6733 FAX: 812-948-5047  
e-Mail: info@SAMTEC.com code: 55322

DESCRIPTION:  
FT5 TERMINAL ASSEMBLY

DWG. NO.  
FT5-XX-XX.X-X-DV-XX-X-TR

BY: R MUSSER 08/04/2009 SHEET 3 OF 3