

THIS DRAWING IS UNPUBLISHED. RELEASED FOR PUBLICATION 20
 © COPYRIGHT 20 BY - ALL RIGHTS RESERVED.

creo
 Creo Parametric 2.0
 DO NOT REVISE
 EXCEPT BY CAD

REVISIONS				
P	LTR	DESCRIPTION	DATE	APVD
	A3	REV. BY ECO 17-005556	28APR2017	HC WLS

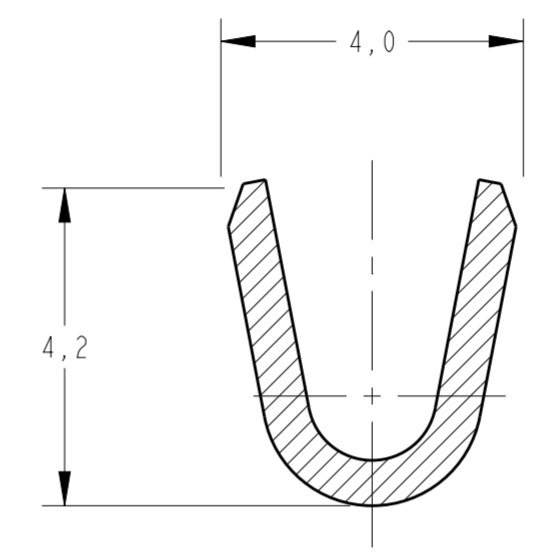
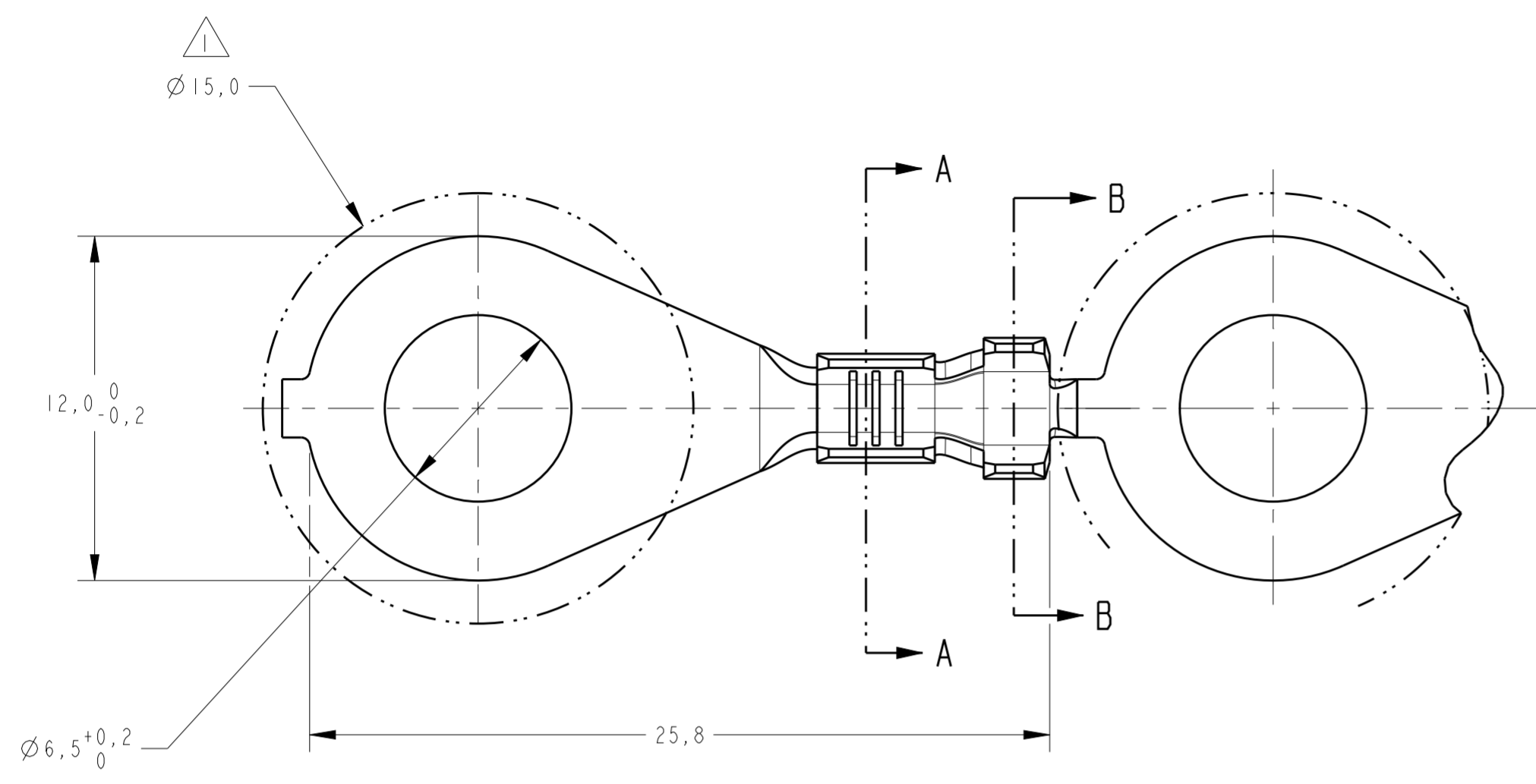

SECTION A-A
 SCALE 10:1

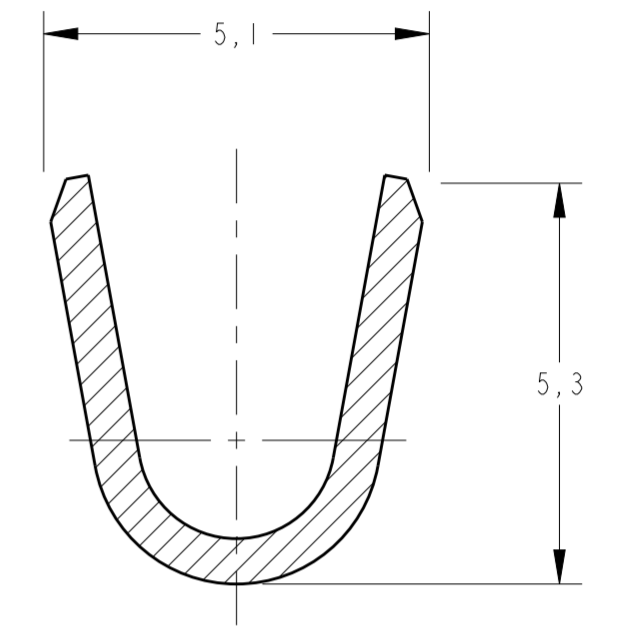

SECTION B-B
 SCALE 10:1

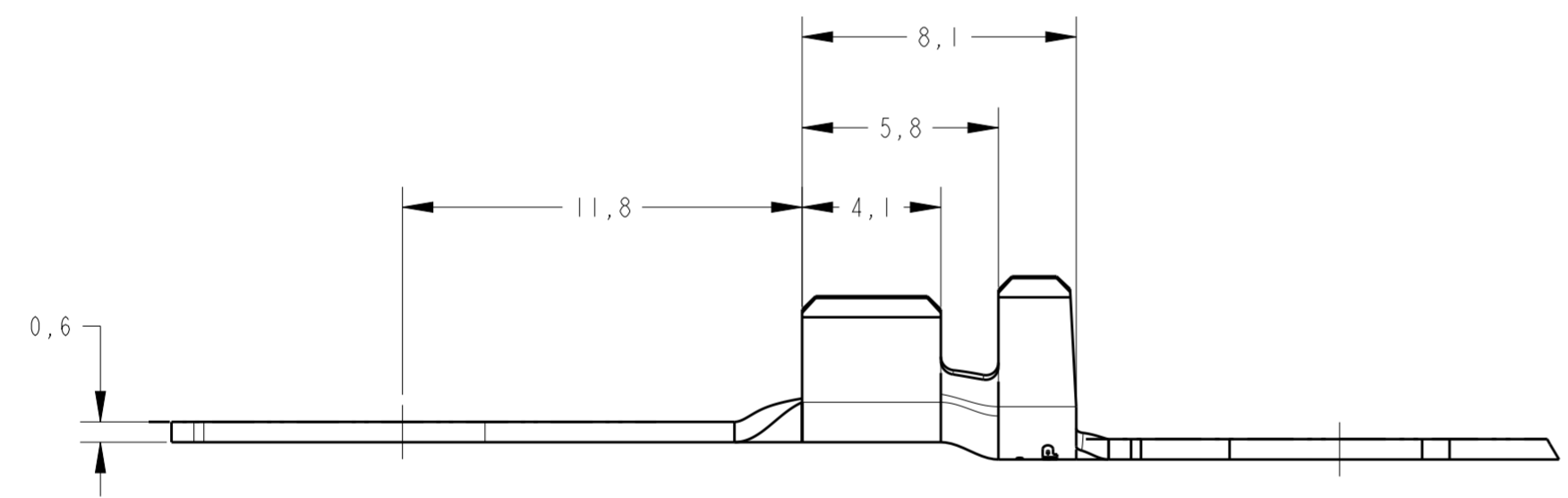

△ - REGIÃO LIVRE PARA FERRAMENTA
 - TOOL CLEARANCE AREA

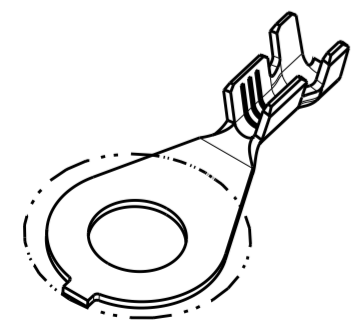

PERSPECTIVE VIEW
 SCALE 2:1

WIRE RANGE	INS. RANGE	FINISH	MATERIAL	PART NUMBER
>1,0-2,5mm ²	∅ 2,1-2,9mm			
OBSOLETE		ELECTRO TIN SPEC.112-16-3 2,5µm	PHOSPHOR BRONZE SPEC.TE 100-221-H04	444155-4
OBSOLETE		PLAIN	PHOSPHOR BRONZE SPEC.TE 100-221-H04	444155-3
		ELECTRO TIN SPEC.112-16-3 2,5µm	LATÃO/BRASS SPEC.TE 100-1512	444155-2
OBSOLETE		PLAIN	LATÃO/BRASS SPEC.TE 100-1512	444155-1

THIS DRAWING IS A CONTROLLED DOCUMENT.		DWN NCLAPRESA 05NOV2014	TE Connectivity	
DIMENSIONS: mm		CHK ECHRISTIANO 05NOV2014		
		APVD LWPRADO 05NOV2014		
TOLERANCES UNLESS OTHERWISE SPECIFIED: mm ²		NAME		RESTRICTED TO
0 PLC ±	1 PLC ±0,3	-		-
2 PLC ±	3 PLC ±	PRODUCT SPEC		-
4 PLC mm ±	ANGLES ±1°	APPLICATION SPEC		-
FINISH		WEIGHT		-
-		-		-
mm ² -		Customer Drawing		SCALE 5:1 SHEET 1 OF 1 REV A3