



User Guide

MP2624 Evaluation Kit (EVKT-2624)

Table of Contents

Overview	2
Introduction	2
Kit Contents	2
Features and Benefits	3
Kit Specifications	3
Section 1. Hardware Specifications	4
1.1 Personal Computer Requirements	4
1.2 EV2624-L-00A Specifications	4
1.3 EVKT-USBI2C-02 Specifications	4
Section 2. Software Requirements	5
2.1 Software Installation Procedure	5
Section 3. Evaluation Kit Test Set-up	6
3.1 Hardware Setup	6
3.2 Powering up the EVB	6
3.3 Software Setup	Error! Bookmark not defined.
3.4 Device Programming Instructions	7
3.5 Troubleshooting Tips	8
Section 4. Ordering Information	9

Overview

Introduction

The EVKT-2624 is an evaluation kit for the MP2624. This board is designed for the MP2624 to be used as a standalone switching charger with integrated USB detection and USB-OTG. The layout accommodates commonly used capacitors. The default function of this board is pre-set for charger mode. The charge full voltage is pre-set to 4.2V for a 1 cell Li-ion battery.

Kit Contents

EVKT-2624 kit contents (items below can be ordered separately).

#	Part Number	Item	Quantity
1	EV2624-L-00A	MP2624 evaluation board	1
2	EVKT-USBI2C-02-BAG	Includes one USB to I ² C communication interface, one USB cable, one ribbon cable	1
3	Online resources	Includes datasheet, user guide, product brief, and GUI	1

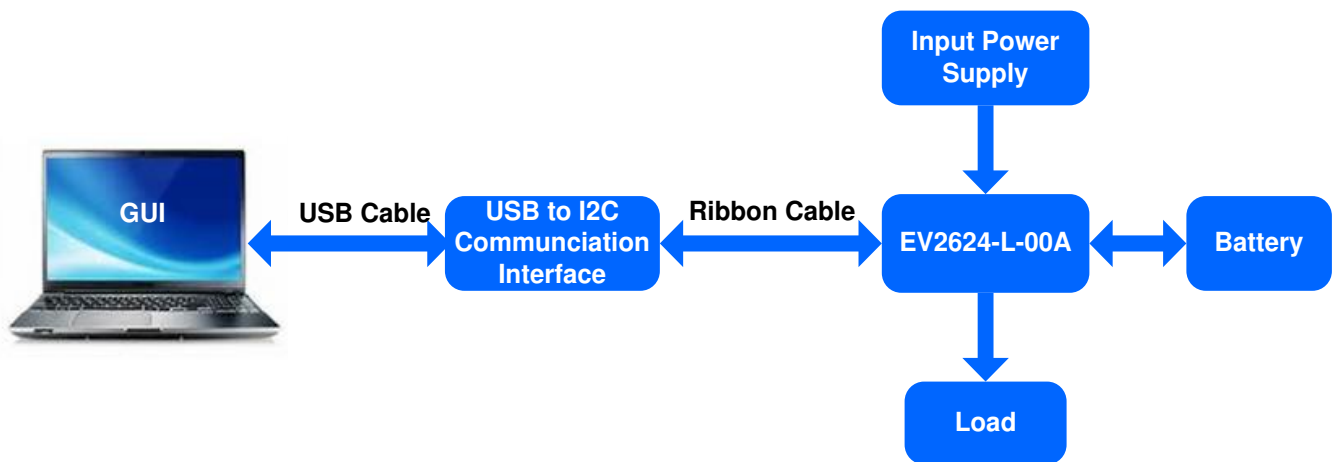

Figure 1: EVKT-2624 Evaluation Kit Set-Up

Features and Benefits

- High Efficiency 4.5A 1.5MHz Buck Charger and 1.5MHz 1.3A Boost Mode to Support OTG
 - Battery Voltage: 3.48V - 4.425V ($\pm 0.5\%$)
 - Charge Current: 512mA - 4544mA ($\pm 5\%$)
 - OTG Current: 500mA / 1.3A
- Single Input USB Compliant Charge
 - Input Voltage: 3.9V - 7.0V
 - Input Current: 100mA - 3000mA ($\pm 5\%$)
- High Integration
 - Fully Integrated Power Switches
 - No External Blocking Diode
 - No External Sense Resistor
 - 10m Ω Battery Discharge MOSFET (up to 9A)
- Constant-Off-Time Control to Reduce Charging Time under Lower Input Voltages
- I²C Port for Flexible System Parameter Setting and Status Reporting
- Built-In Battery Disconnection Function to Support Shipping Mode
- Safety Features
 - Battery Temperature Sensing for Charge Mode
 - Battery Charging Safety Programmable Timer
 - Thermal Regulation and Thermal Shutdown
 - Battery/System Over-Voltage Protection
 - MOSFET Over-Current Protection
 - Thermal Limiting Regulation on Chip

⚠ All changes made in I²C mode will NOT be retained once the EVB is powered down.

⚠ Information written in OTP mode CANNOT be changed.

Adjustable Features:

I ² C	OTP
<ul style="list-style-type: none"> • Charge Full Voltage • Charge Current • Input Voltage Regulation • Input Current Limit • OTG Voltage Regulation • OTG Current Limit 	<ul style="list-style-type: none"> • None

Kit Specifications

Feature	Specification
Supply for Board	3.9V - 7.0V
Operating Input Voltage	3.9V - 7.0V
Operating Systems Supported	Windows XP, 7, and later
System Requirements	Minimum 22.2 MB free
GUI Software	MP2624 V1.6

Section 1. Hardware Specifications

1.1 Personal Computer Requirements

Minimum requirements to use the EVKT-2624:

- Operating System of Windows XP, 7 or later
- Net Framework 4.0
- PC with a minimum of one available USB port
- At least 22.2 MB of free space

1.2 EV2624-L-00A Specifications

The EV2624-L-00A is an evaluation board for the MP2624. For more information, please refer to the EV2624-L-00A datasheet.



Figure 2: EV2624-L-00A Evaluation Board

Feature	Specification
Supply for Evaluation Board	3.9V - 7.0V
Operating Input Voltage	3.9V - 7.0V
EVB Size (L X W)	6.3cm X 6.3cm

1.3 EVKT-USBI2C-02 Specifications

The EVKT-USBI2C-02 refers to the communication interface, which connects the EVB, PC and its supporting accessories. It provides I²C capabilities. Together with the MPS Virtual Bench Pro and I²C GUI tools, it provides a quick and easy way to evaluate the performance of MPS digital products. For more details, refer to the EVKT-USBI2C-02 datasheet.



Figure 3: EVKT-USBI2C-02 Communication Interface

Section 2. Software Requirements

2.1 Software Installation Procedure

Programming occurs through the MPS I²C GUI. Follow the instructions below to install the software.

Note: This software can be downloaded from the MPS website.

1. Download and extract the zip package for the “I²C evaluation kit software for MP2624” to a directory of your choice.
2. Double click the .EXE file and open the software. (see Figure 4).
3. Follow the prompts in the set-up guide.
4. Wait for the status screen to verify that installation is complete (see Figure 5).

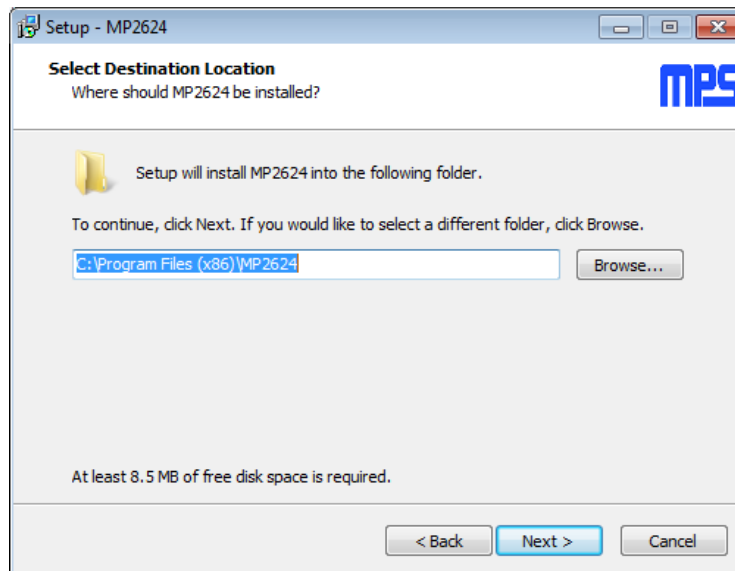

Figure 4: MPS I²C GUI Set-Up Guide

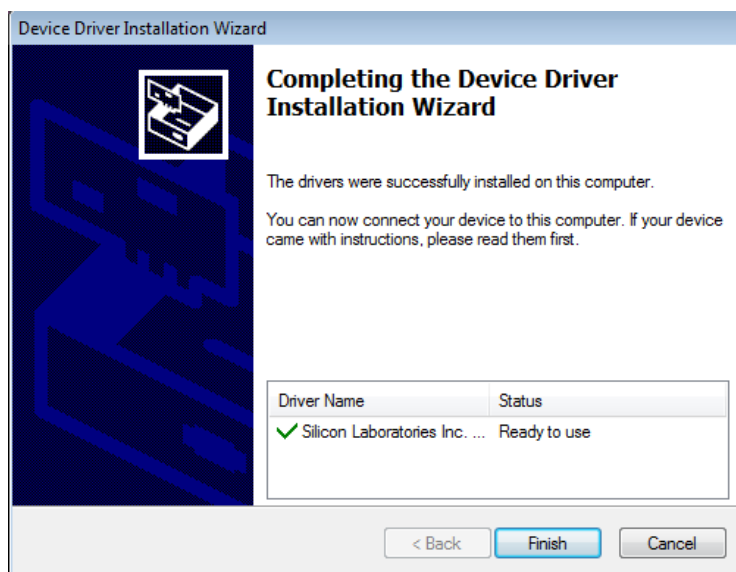

Figure 5: Driver Set-Up Success

Section 3. Evaluation Kit Test Set-up

3.1 Hardware Setup

The hardware must be properly configured prior to use. Follow the instructions below to set up the EVB.

1. Locate the proper wires to connect the EVB to the EVKT-USBI2C-02 communication interface.
2. Connect SCL, SDA, and GND (see Figure 6). If needed, refer to the datasheet for further clarification.

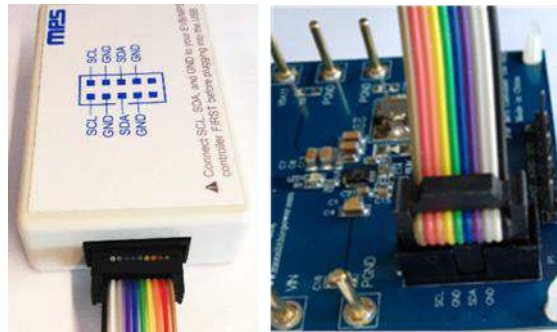

Figure 6: EVB to MPS I²C Communication Interface Wire Connection

3.2 Powering up the EVB

1. Connect the positive and negative terminals of the load to the VSYS and PGND pins, respectively.
2. Connect the positive and negative terminals of the battery to the VBATT and PGND pins, respectively. If it is a battery simulator, pre-set the battery voltage between 0V and 4.545V, then turn it off. Connect the battery simulator output to the BATT and PGND pins respectively.
3. Pre-set the power supply output between 3.9V and 7.0V, then turn off the power supply. Connect the positive and negative terminals of the power supply output to the VIN and PGND pins, respectively.
4. **Make sure the battery voltage has been pre-set** (if a battery simulator is used, **turn on the battery emulator**). Then, turn the power supply on. The IC will enter the power-on sequence automatically.

3.3 Software Set-Up

After connecting the hardware (see Section 3.1 and Section 3.2), follow the steps below to use the GUI software.

1. Start the software. It will check the EVB connection automatically.
 - If connection is successful, both the USB and MP2624 DEMO board statuses will say "connected." (see Figure 7).

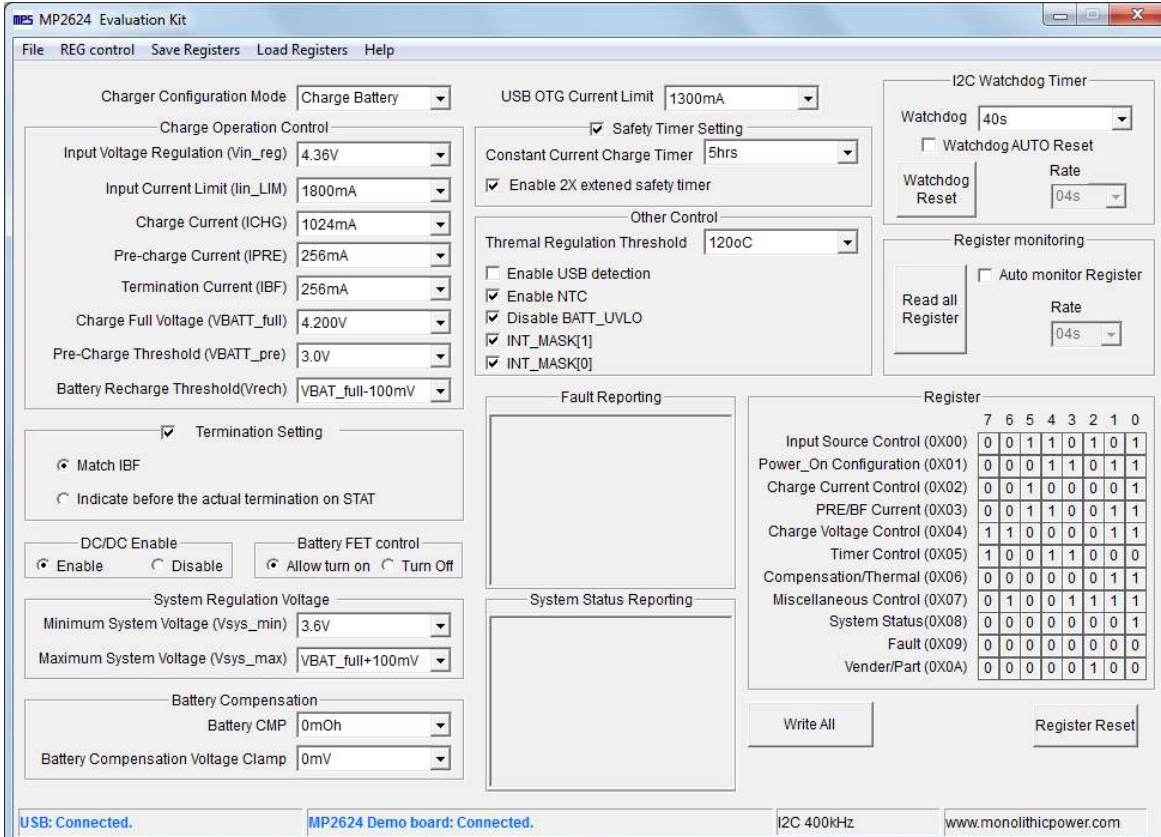

Figure 7: USB and MP2624 EVB Board Connected

2. If connection is not successful, "Not Connected" will appear in red. Check the connections between the EVB, communication interface, and PC. Re-plug the USB into the computer.
 - 1) MP2624 DEMO Board "Not Connected" means that the evaluation board is not connected correctly.
 - 2) USB "Not Connected" means that the USB I²C communication interface is not connected correctly.
3. Click the "Read All Register" button to read the I²C register values. The default values are displayed (see Figure 7).
4. Find the item you want to change and select the desired value from the drop down menu.
5. Click the "Write All" button to update values. The changed information of the item will be downloaded to the IC.

⚠ All changes made via I²C will be restored to default values once the EVB is powered down.

3.4 Troubleshooting Tips

- **EVKT-USBI2C-02 Driver Problem**

In case the USBI2C-02 driver is not properly installed, manual installation is required. Follow the steps below.

1. Install the correct “.exe” file according to the windows operation system.
32-bit: \EVKT-USBI2C-02 USB Driver\USBXpressInstaller_x86.exe.
64-bit:\EVKT-USBI2C-02 USB Driver\USBXpressInstaller_x64.exe.
2. Connect the communication interface to the PC with a USB cable.
3. Find the “USBXpress Device” in the Device Manager (see below):

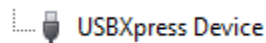

If the PC is running Windows10, check the driver version of the USBXpress Device. Windows 10 will automatically install the older USB driver, which is not compatible. The correct driver version is 4.0.0.0 (see Figure 8).

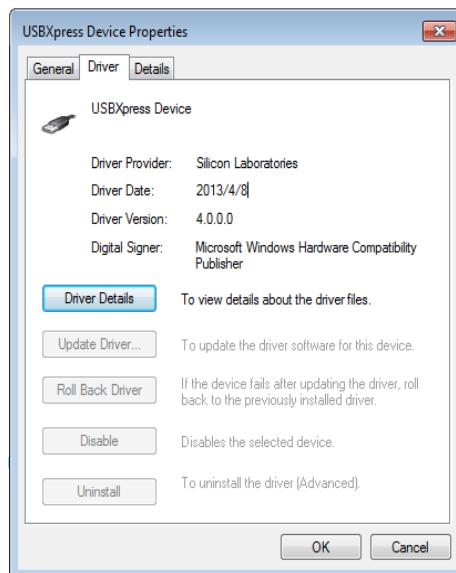

Figure 8: Correct Driver Version is 4.0.0.

- **No Supply**

The IC’s input pin has an under-voltage lockout (UVLO) detection circuit. If the input voltage (VIN) is lower than the UVLO rising threshold, the charging function is disabled.

- **No Charging Event**

If the IC detects that the input voltage is lower than the UVLO falling threshold (it enters a no supply state) or over-temperature protection is triggered (The PWM step-down converter enters a shutdown state), the IC switches to supplement mode powered by the battery.

- **Thermal Recovery**

If the MP2624 (PWM step-down converter) is in a shutdown state due to the die temperature exceeding the thermal protection threshold, the IC enters a power-on sequence when the die’s temperature decreases.

Section 4. Ordering Information

The components of the evaluation kit can be purchased separately.

Part Number	Description
EVKT-2624	Complete evaluation kit
Contents of EVKT-2624	
EV2624-L-00A	MP2624 evaluation board
EVKT-USBI2C-02-BAG	Includes one USB to I ² C communication interface, one USB cable, one ribbon cable,
Online resources	Includes datasheet, user guide, product brief, and GUI

Order directly from MonolithicPower.com or our distributors.