



NEH2000BY

Energy harvesting PMIC

Rev. 3.1 — 3 April 2023

Product data sheet

1. General description

NEH2000BY is a high-performance energy harvesting solution for low-power applications. The NEH2000BY harvests energy generated by a photo-voltaic (PV) cell. The energy charges a rechargeable battery.

Nexperia's advanced Maximum Power Point Tracking (MPPT) uses an embedded hill-climbing algorithm to deliver the maximum power to the load. The MPPT is designed to be independent of specific characteristics of the harvesters, therefore any harvester that fits the specifications of the chip can be used. Moreover, the MPPT circuit can detect the maximum power point with an interval of 0.7 second resulting in maximum efficiency in various environments where energy can rapidly change over time.

The NEH2000BY is available in a Plastic 16 terminal Quad Flat package, 3 mm x 3 mm.

2. Features and target applications

Features and benefits

- High-efficiency low-power 2x boosting DC-to-DC converter
- Harvesting power range from 35 μ W to 2 mW
- Advanced MPPT to maximize efficiency
- Ultra fast MPPT interval of 0.7 second
- Small BOM with no external inductor required
- Compatible with various types of rechargeable batteries

Applications

- Wireless IoT devices
- Smart remote controls
- Electronic shelf labels
- Wearable devices
- Industrial and environmental monitoring
- Consumer electronics
- Beacons

3. Typical application

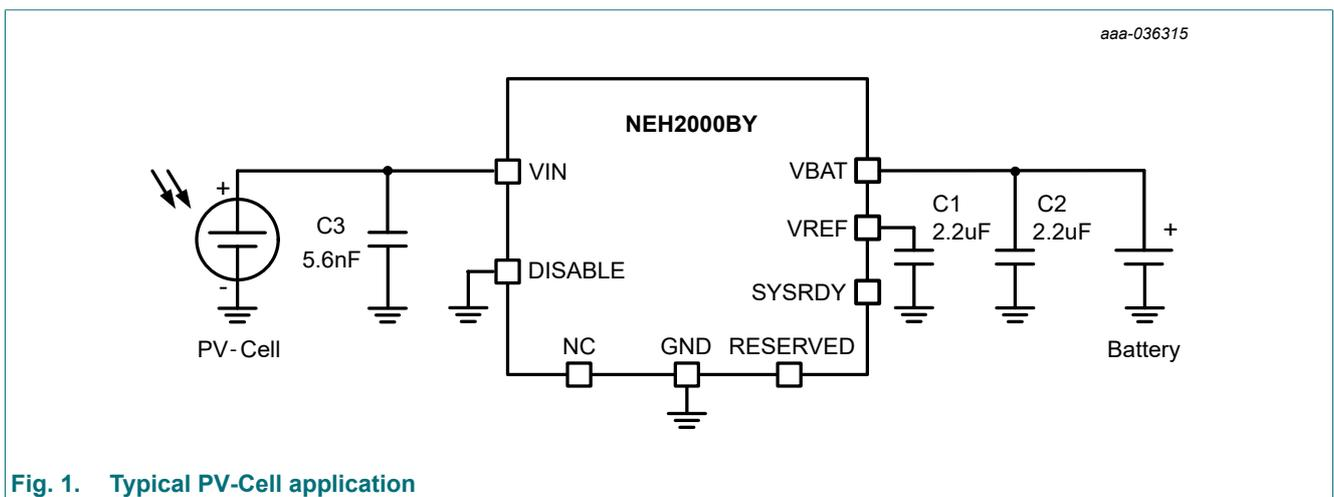

4. Pinning information

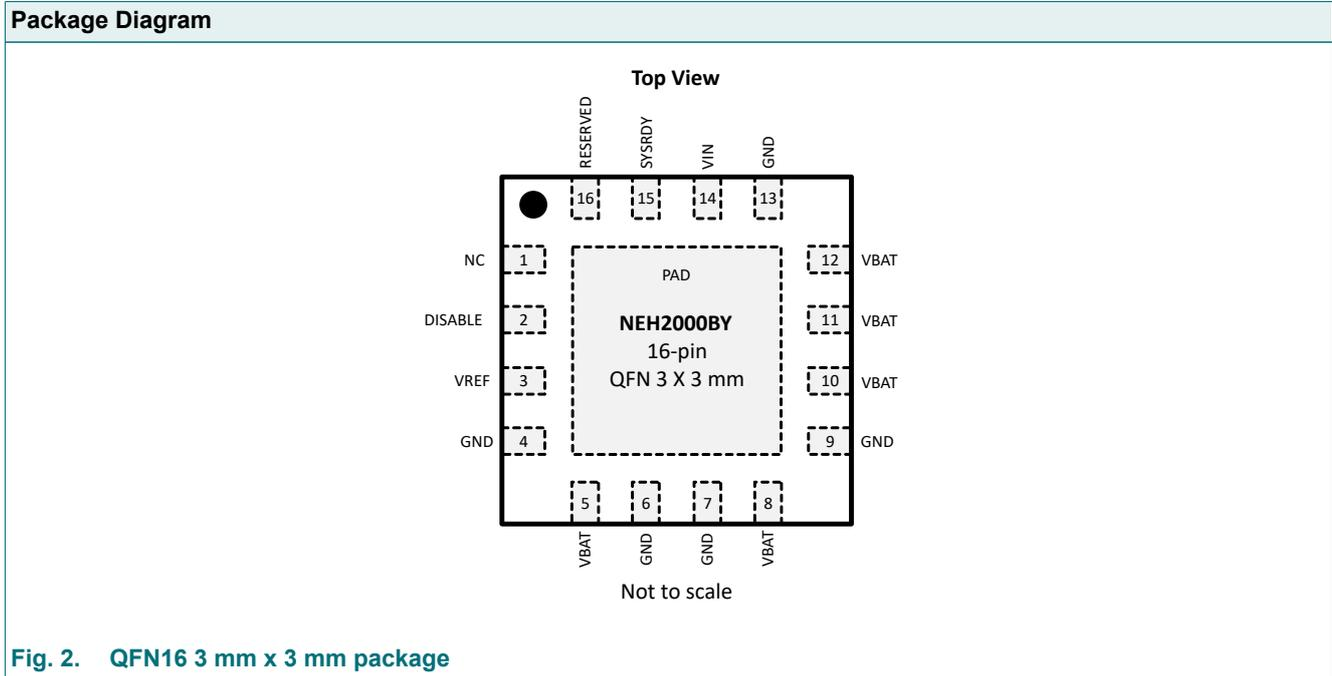

Fig. 2. QFN16 3 mm x 3 mm package

Table 1. Pinning information

Pin	Symbol	Description
1	NC	not connected; can be floating or grounded
2	DISABLE	Disable pin. Harvester is active when connected to GND. This pin can be used to deactivate harvesting in case battery is full
3	VREF	decoupling for internal supply generation; no external load supported
4	GND	ground
5	VBAT	output of the energy harvester and device supply
6	GND	ground
7	GND	ground
8	VBAT	connect to V_{BAT}
9	GND	ground
10	VBAT	connect to V_{BAT}
11	VBAT	connect to V_{BAT}
12	VBAT	output of the energy harvester and device supply
13	GND	ground
14	VIN	DC input of energy harvester
15	SYSRDY	System Ready output; indicates (HIGH) when start-up of device is ready
16	RESERVED	reserved; should be left floating
PAD	GND	ground

5. Ordering information

Table 2. Ordering information

Type number	Package		
	Name	Description	Version
NEH2000BY	SOT8076-1	Plastic Quad Flat package, no leads; 16 terminals: 0.5 mm pitch 3 mm x 3 mm x 0.75 mm body	1.0

6. Block Diagram

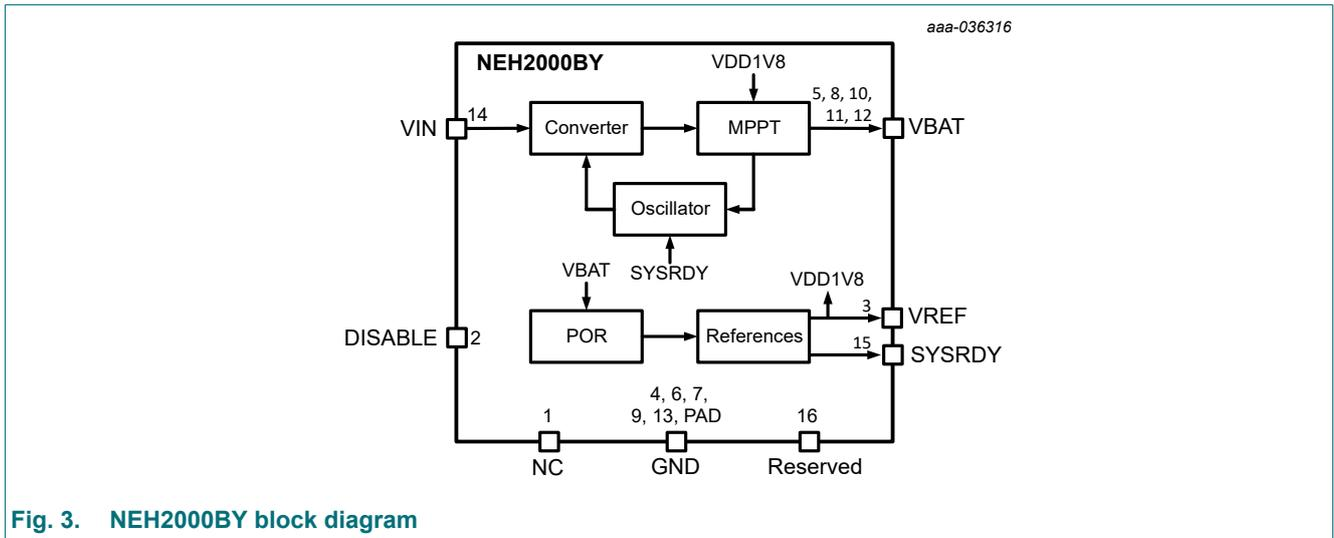

Fig. 3. NEH2000BY block diagram

7. Limiting values

Table 3. Limiting values

In accordance with the Absolute Maximum Rating System (IEC 60134). Voltages are referenced to GND (ground = 0 V).

Symbol	Parameter	Conditions	Min	Max	Unit
V_{IN}	input voltage [1]		-0.3	$V_{BAT} + 0.3$	V
			-0.3	5	V
V_{BAT}	battery voltage		-0.3	5	V
$V_{DISABLE}$	DISABLE input voltage		-0.3	5	V
I_{IN}	input current		-	100	mA
V_{ESD}	ESD voltage	Charged Device Model (CDM)	750	-	V
		Human Body Model (HBM)	2000	-	V
T_j	junction temperature		-50	+125	°C
T_{stg}	storage temperature		-65	+150	°C

[1] To prevent damage to the device, do not apply $V_{IN} > 2$ V in case no battery connected.

8. Recommended operating conditions

Table 4. Recommended operating conditions

Symbol	Parameter	Conditions	Min	Typ	Max	Unit
V_{BAT}	battery voltage		2.5	-	4.5	V
T_{amb}	ambient temperature		-40	-	+85	°C

9. Thermal characteristics

Table 5. Thermal characteristics

Symbol	Parameter	Conditions	Min	Typ	Max	Unit
$R_{th(j-a)}$	thermal resistance junction to ambient	in free air	-	-	47	K/W
$R_{th(j-c)}$	thermal resistance junction to case (top)		-	-	1	K/W

10. Characteristics

Table 6. Characteristics

$V_{BAT} = 3\text{ V}$, $V_{OC} = 3\text{ V}$. Typical values specified at $T_{amb} = 25\text{ °C}$, Min and Max values specified at $T_{amb} = -40\text{ °C}$ to 85 °C . Voltages are referenced to GND (ground = 0 V).

Symbol	Parameter	Conditions	Min	Typ	Max	Unit
Supplies and start-up						
$V_{BAT(min)}$	minimum battery voltage	to startup SYSRDY becomes high	-	2.5	-	V
		after startup SYSRDY is high	-	2	-	V
V_{IN}	harvester input voltage	[1]	-	1.65	-	V
I_{STBY}	standby current		400	625	1150	nA
V_{REF}	internally generated supply		-	1.8	-	V
t_{start}	start-up time	time for SYSRDY to become high after applying V_{BAT} ; $-20\text{ °C} < T_{amb} < 85\text{ °C}$	-	50	-	ms
Power converter						
$P_{IN(min)}$	minimum input power	efficiency = 70%	-	35	-	μW
$P_{IN(max)}$	maximum input power	efficiency = 70%	-	2	-	mW
t_{MPPT}	MPPT interval		-	0.7	-	s
t_{MPPT_OPT}	time for MPPT optimization		-	10	-	ms
$f_{CONV(min)}$	minimum power converter frequency	$P_{in} = 35\text{ μW}$	-	50	-	kHz
$f_{CONV(max)}$	maximum power converter frequency	$P_{in} = 2\text{ mW}$	-	1.8	-	MHz
Control						
V_{IL}	logic low level for DISABLE		-	-	$0.1 \times V_{BAT}$	V
V_{IH}	logic high level for DISABLE		$0.9 \times V_{BAT}$	-	-	V

[1] To prevent battery charging directly from the PV-cell take care that V_{OC} is lower than V_{BAT} plus a diode voltage ($\sim 0.5\text{ V}$)

10.1. Typical performance characteristics

$V_{BAT} = 3\text{ V}$, $V_{OC} = 3\text{ V}$, $T_{amb} = 25\text{ }^\circ\text{C}$, unless otherwise specified.

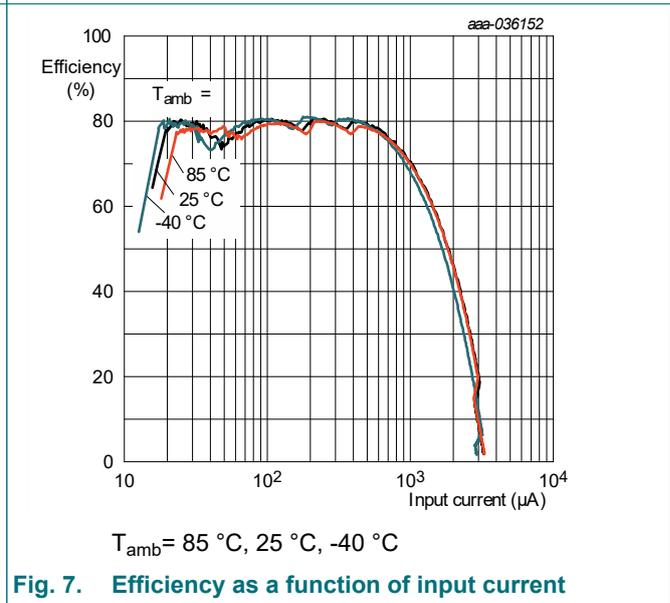
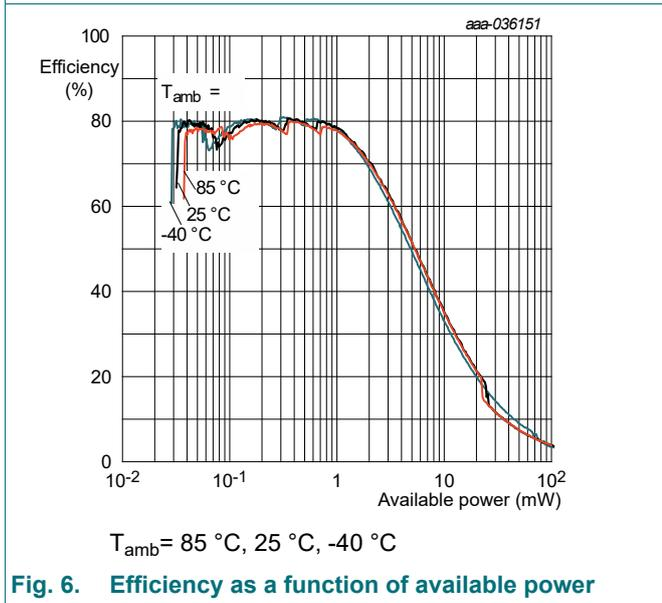
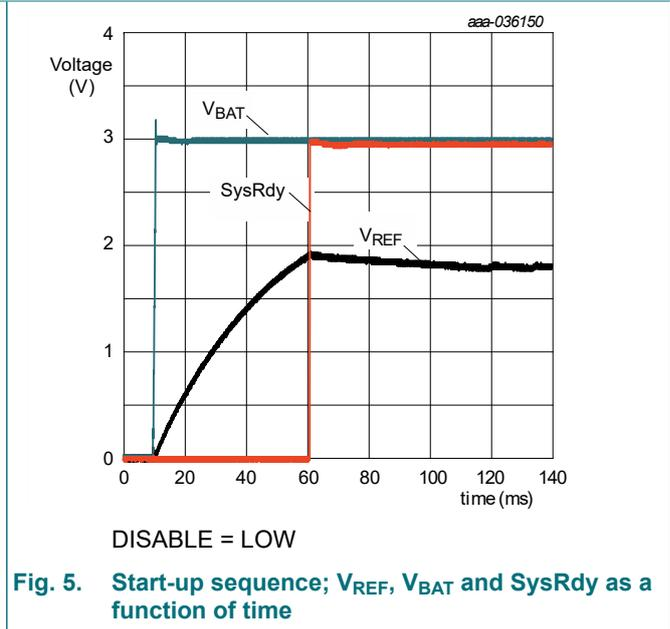
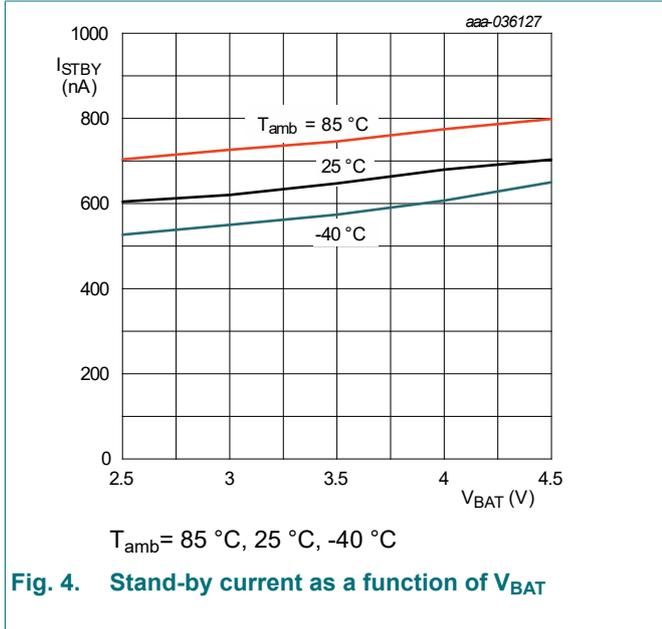

$V_{BAT} = 3\text{ V}$, $V_{OC} = 3\text{ V}$, $T_{amb} = 25\text{ }^{\circ}\text{C}$, unless otherwise specified.

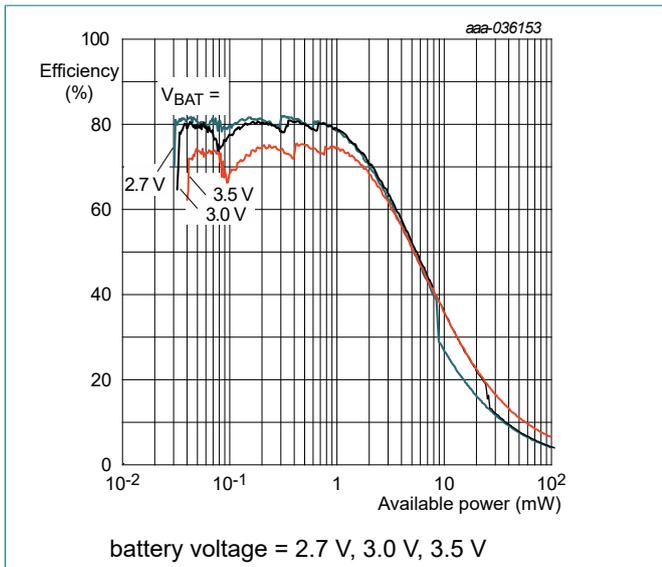

Fig. 8. Efficiency as a function of available power

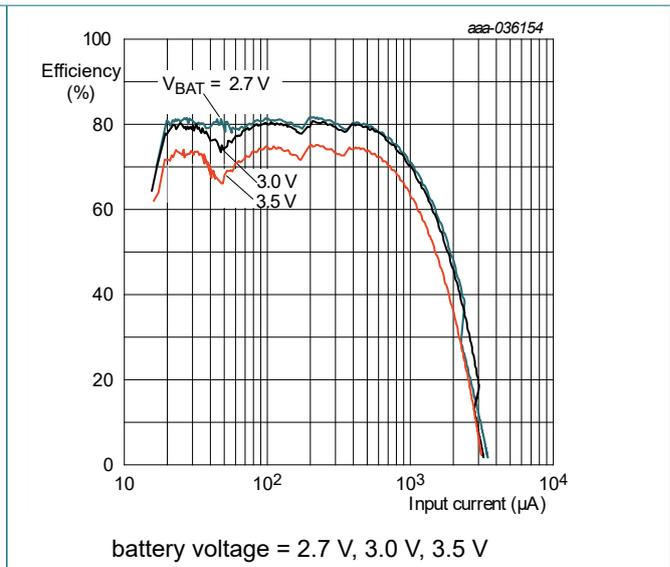

Fig. 9. Efficiency as a function of input current

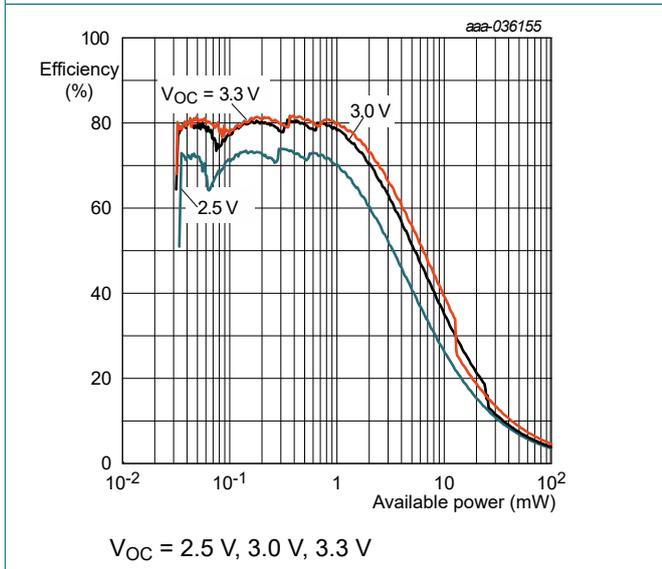

Fig. 10. Efficiency as a function of available power

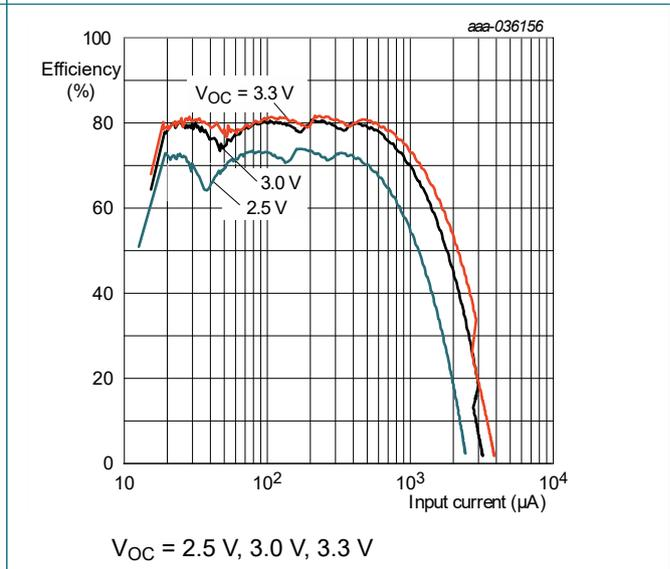

Fig. 11. Efficiency as a function of input current

11. Application information

11.1. Typical application

A typical PV-cell application is shown in Fig. 12. Table 7 lists the Bill of Materials.

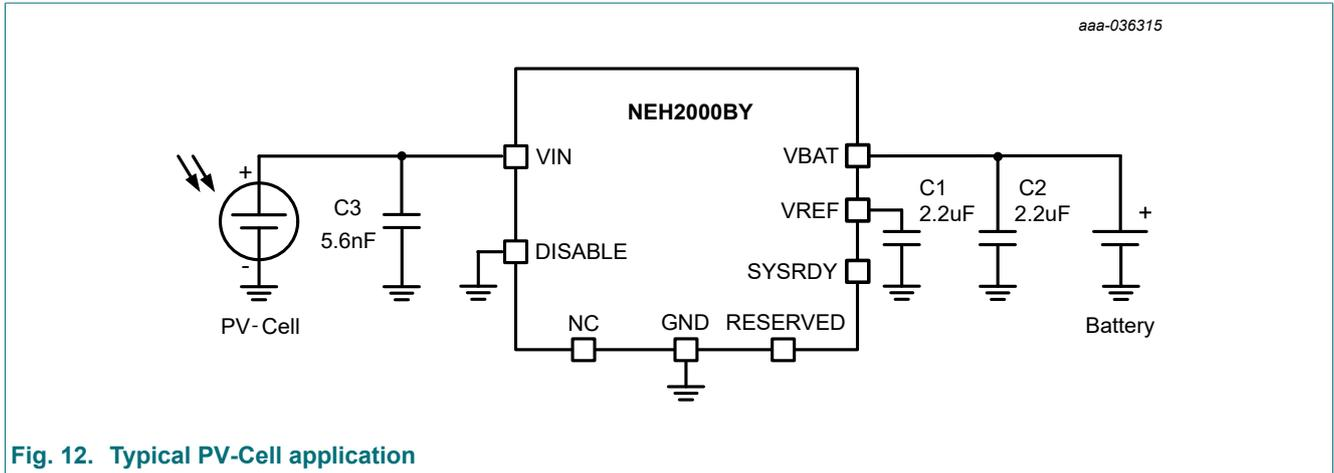

Fig. 12. Typical PV-Cell application

Table 7. Bill of Materials

Reference designator	Description	Type	Value	Quantity
U1	PMIC	NEH2000BY	-	1
C1, C2	capacitor	X7R / 6.3 V	2.2 μ F	2
C3	capacitor	X7R / 6.3 V	5.6 nF	1

11.2. Harvesting efficiency

The overall efficiency (Eff_{total}) of the NEH2000BY in combination with a PV-cell comprises two components (see Fig. 13):

- $Eff_{converter}$: The efficiency of the power converter in the NEH2000BY
- Eff_{match} : The matching efficiency between the NEH2000BY and the PV-cell

$$Eff_{total} = Eff_{converter} \times Eff_{match} \tag{1}$$

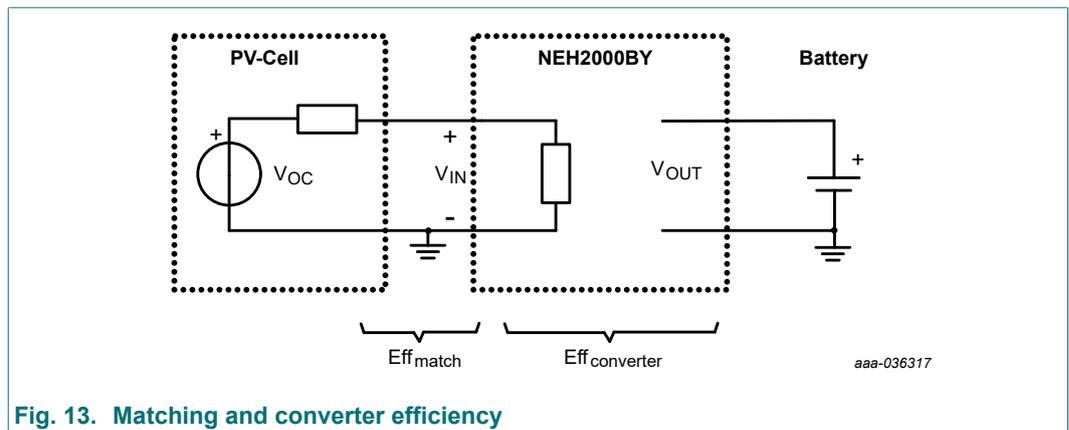

Fig. 13. Matching and converter efficiency

11.3. Power converter efficiency

In practice, a power converter has losses from input power (P_{IN}) to output power (P_{OUT}). The ratio of the output power and input power, is typically referred to as the power-converter efficiency:

$$\text{Eff}_{\text{converter}} = \frac{P_{\text{OUT}}}{P_{\text{IN}}} \times 100 \% \quad (2)$$

For common inductive and capacitive power converters this efficiency is in the range of 80% to 95%. Several characteristics can have an impact on this efficiency, such as: ratio of the output voltage and input voltage; quality and size of the converter capacitors / inductors, fully integrated or external components, etc. The NEH2000BY has a fully integrated power converter. In its targeted power range the converter efficiency is about 82%.

11.4. Matching efficiency

In general, power transfer between components is optimized by matching the receiving input impedance with the transmitting output impedance. In a harvesting system it is also important to transfer power from harvester to the power converter in the most efficient manner to minimize loss of harvested energy. How optimal power transfer between PV-cell and power converter is, can be expressed by matching efficiency.

The matching efficiency is defined as

$$\text{Eff}_{\text{match}} = \frac{P_{\text{IN}}}{P_{\text{available}}} \times 100 \% \quad (3)$$

Where P_{IN} is the actual power at the input of the power converter and $P_{\text{available}}$ is the maximum power that can be achieved at the input (which is at 100% matching).

From the graphs in [Section 10.1](#), ([Fig. 8](#) to [Fig. 11](#)), it can be seen that the matching efficiency (as part of the overall efficiency) has a dependency on the ratio of V_{OC} and V_{BAT} . Both relate in a certain way to the power converter's input. The V_{BAT} relation can be understood from the perspective that the capacitive power converter has a given boost factor between input and output:

$$V_{\text{IN}} = \frac{V_{\text{BAT}}}{\text{Boosting factor}} \quad (4)$$

Where the actual boosting factor of the NEH2000BY is about 1.8 (unloaded boosting is 2).

The open-circuit voltage (V_{OC}) of a PV-cell relates to power converters input via the maximum power-point tracking voltage (V_{MPPT}). This is the voltage on the power converter's input where most power is delivered by the PV-cell:

$$V_{\text{MPPT}} = 0.7 \dots 0.9 \times V_{\text{OC}} \quad (5)$$

The typical MPPT ratio (V_{MPPT}/V_{OC}) of a PV-cell is 0.8.

Combining equations (4) and (5), the following guideline for V_{OC} applies:

$$\begin{aligned} V_{\text{OC}} &= \frac{V_{\text{BAT}}}{\text{Boosting factor} \times \text{MPPT ratio}} \\ V_{\text{OC}} &= 0.69 \times V_{\text{BAT}} \end{aligned} \quad (6)$$

Thus, for optimal matching efficiency a PV-cell should be chosen with a V_{OC} that is $0.69 \times V_{BAT}$.

11.5. Guideline for PV-cell selection

In this section a guideline is given for the selection of a PV-cell in an NEH2000BY application. Following this guideline will yield the best overall efficiency for the energy harvesting of the application. It is based on the optimum matching efficiency as described in the previous section.

Taking into account that the maximum-power point of a PV cell is about $0.8 \times V_{OC}$, the following guideline for the PV-cell applies:

$$V_{OC} = 0.5 \dots 0.8 \times V_{BAT} \tag{7}$$

11.6. Enhanced low input power operation

In case operation at very low input power levels is desired, the NEH2000BY can be configured for operation starting at 10 μ W input power. In this case, the power range shifts down by about a factor of 2. Please contact Nexperia for the appropriate configuration.

11.7. Full battery protection

In general, a battery should not be over-charged. Continue charging in that case can damage the battery. An energy harvester, like the NEH2000BY should therefore stop harvesting once the battery is fully charged. This can be implemented by adding an over-voltage protection device (OVP) to the harvester (see Fig. 14).

Detecting whether a battery is fully charged or not can be done by observing the battery voltage. Each battery type has its own maximum allowed voltage. An OVP device can monitor the battery voltage V_{BAT} . Once the maximum allowed battery voltage is detected the OVP device will assert its output and by that disable the harvester. Once the V_{BAT} level drops below the release voltage of the OVP device, harvesting commences again.

OVP devices are available in many different types. The OVP device should have an over-voltage detection level that corresponds to the maximum allowed battery voltage. The output logic of the OVP should be chosen such that the output is high when the maximum battery voltage is at or above the allowed level.

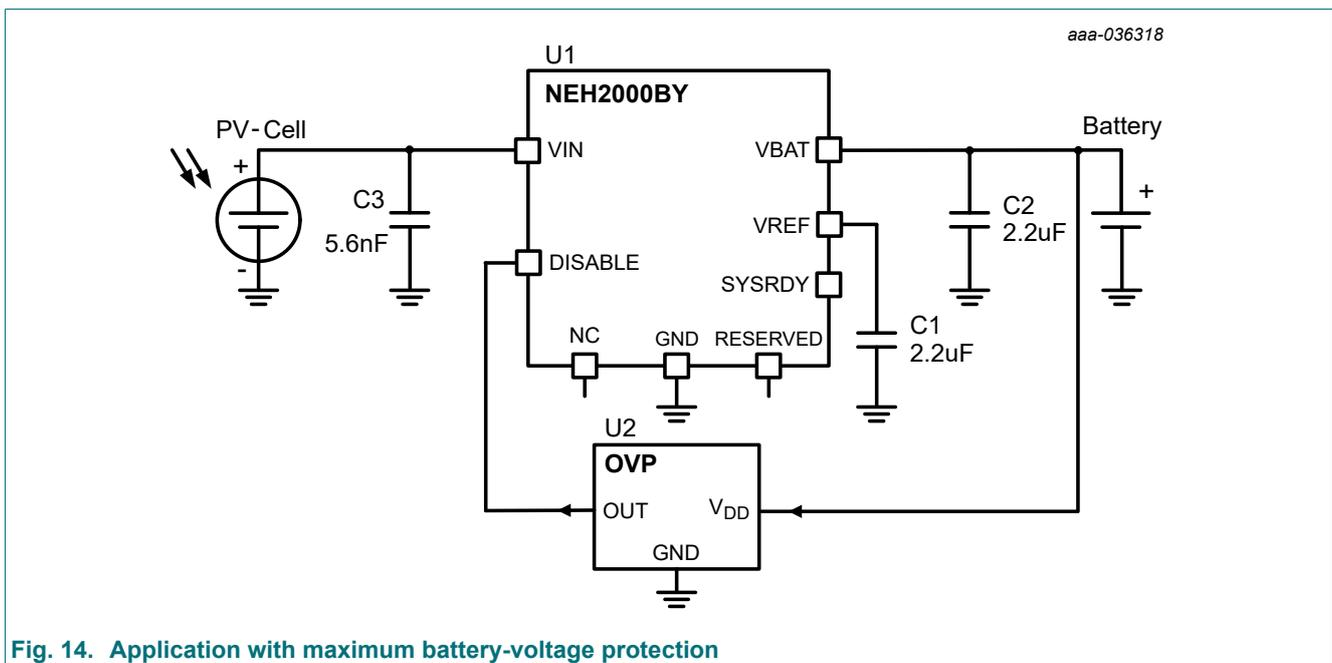

Fig. 14. Application with maximum battery-voltage protection

12. Package outline

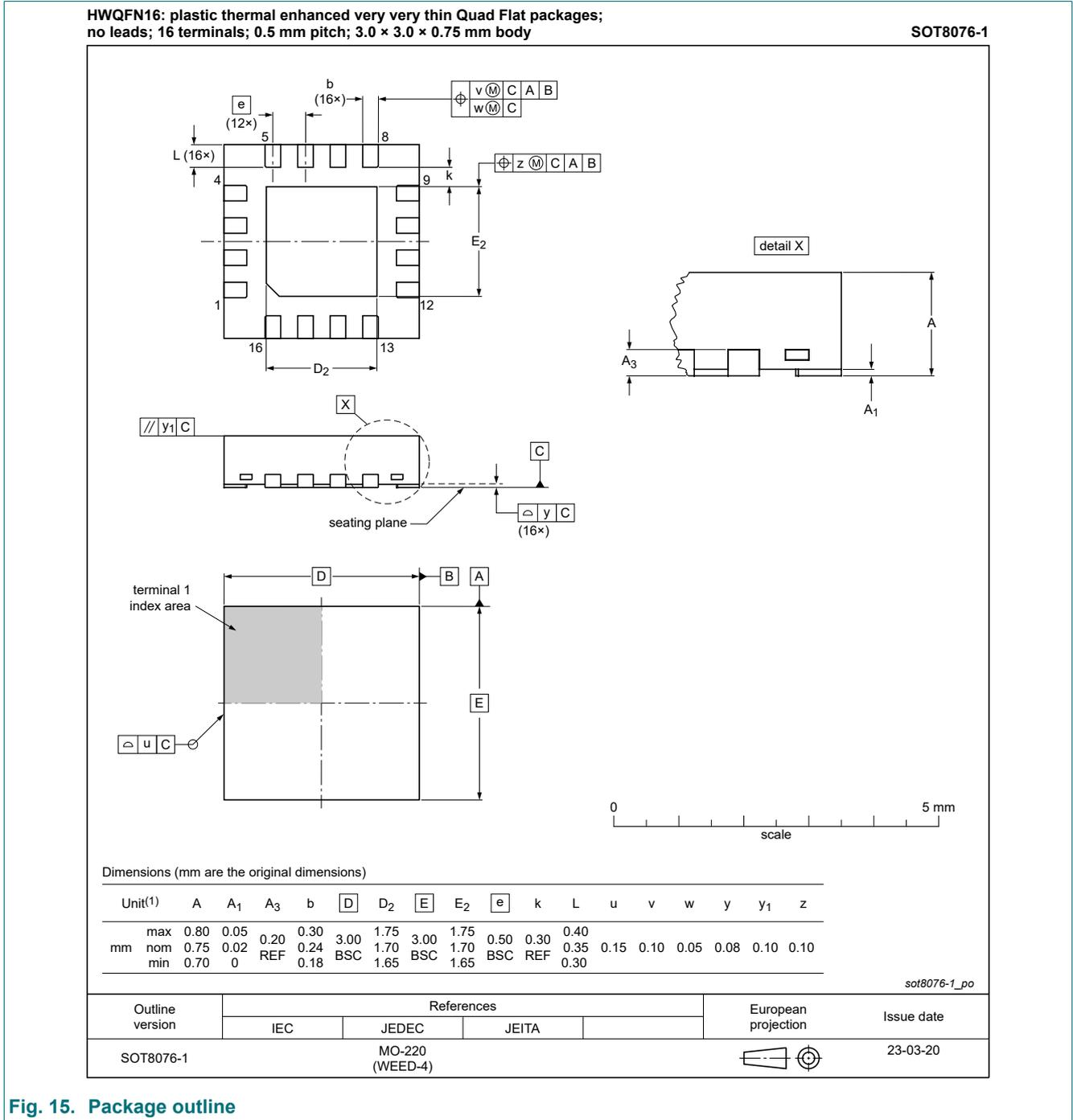

Fig. 15. Package outline

13. Soldering

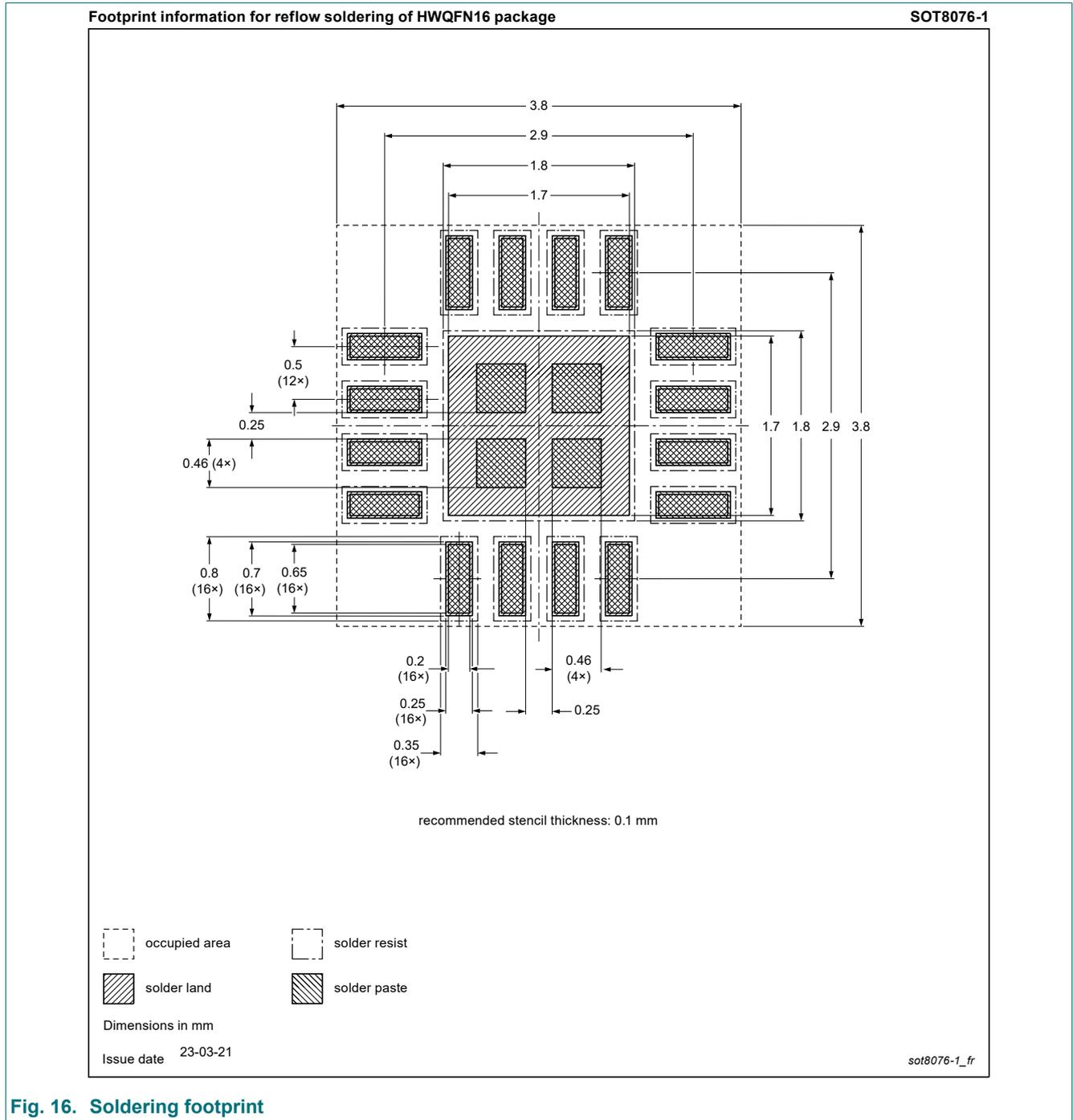

Fig. 16. Soldering footprint

14. Revision history

Table 8. Revision history

Document ID	Release date	Data sheet status	Change notice	Supersedes
NEH2000BY v.3.1	20230403	Product data sheet	-	NEH2000BY v.3
Modifications:	Footnote added in Table 3 , Table 6 format adjusted.			
NEH2000BY v.3	20230328	Product data sheet	-	NEH2000BY v.2
Modifications:	Pin names updated. Section 11.4 , Section 11.5 and Section 12 revised.			
NEH2000BY v.2	20230302	Preliminary data sheet	-	NEH2000BY v.1
Modifications:	Updated to latest Nexperia technical document format			
NEH2000BY v.1 <i>note: previously named NH2D0245 Revision 1.0</i>	20221101	Preliminary data sheet	-	-

15. Legal information

Data sheet status

Document status [1][2]	Product status [3]	Definition
Objective [short] data sheet	Development	This document contains data from the objective specification for product development.
Preliminary [short] data sheet	Qualification	This document contains data from the preliminary specification.
Product [short] data sheet	Production	This document contains the product specification.

- [1] Please consult the most recently issued document before initiating or completing a design.
- [2] The term 'short data sheet' is explained in section "Definitions".
- [3] The product status of device(s) described in this document may have changed since this document was published and may differ in case of multiple devices. The latest product status information is available on the internet at <https://www.nexperia.com>.

Definitions

Draft — The document is a draft version only. The content is still under internal review and subject to formal approval, which may result in modifications or additions. Nexperia does not give any representations or warranties as to the accuracy or completeness of information included herein and shall have no liability for the consequences of use of such information.

Short data sheet — A short data sheet is an extract from a full data sheet with the same product type number(s) and title. A short data sheet is intended for quick reference only and should not be relied upon to contain detailed and full information. For detailed and full information see the relevant full data sheet, which is available on request via the local Nexperia sales office. In case of any inconsistency or conflict with the short data sheet, the full data sheet shall prevail.

Product specification — The information and data provided in a Product data sheet shall define the specification of the product as agreed between Nexperia and its customer, unless Nexperia and customer have explicitly agreed otherwise in writing. In no event however, shall an agreement be valid in which the Nexperia product is deemed to offer functions and qualities beyond those described in the Product data sheet.

Disclaimers

Limited warranty and liability — Information in this document is believed to be accurate and reliable. However, Nexperia does not give any representations or warranties, expressed or implied, as to the accuracy or completeness of such information and shall have no liability for the consequences of use of such information. Nexperia takes no responsibility for the content in this document if provided by an information source outside of Nexperia.

In no event shall Nexperia be liable for any indirect, incidental, punitive, special or consequential damages (including - without limitation - lost profits, lost savings, business interruption, costs related to the removal or replacement of any products or rework charges) whether or not such damages are based on tort (including negligence), warranty, breach of contract or any other legal theory.

Notwithstanding any damages that customer might incur for any reason whatsoever, Nexperia's aggregate and cumulative liability towards customer for the products described herein shall be limited in accordance with the Terms and conditions of commercial sale of Nexperia.

Right to make changes — Nexperia reserves the right to make changes to information published in this document, including without limitation specifications and product descriptions, at any time and without notice. This document supersedes and replaces all information supplied prior to the publication hereof.

Suitability for use — Nexperia products are not designed, authorized or warranted to be suitable for use in life support, life-critical or safety-critical systems or equipment, nor in applications where failure or malfunction of an Nexperia product can reasonably be expected to result in personal

injury, death or severe property or environmental damage. Nexperia and its suppliers accept no liability for inclusion and/or use of Nexperia products in such equipment or applications and therefore such inclusion and/or use is at the customer's own risk.

Quick reference data — The Quick reference data is an extract of the product data given in the Limiting values and Characteristics sections of this document, and as such is not complete, exhaustive or legally binding.

Applications — Applications that are described herein for any of these products are for illustrative purposes only. Nexperia makes no representation or warranty that such applications will be suitable for the specified use without further testing or modification.

Customers are responsible for the design and operation of their applications and products using Nexperia products, and Nexperia accepts no liability for any assistance with applications or customer product design. It is customer's sole responsibility to determine whether the Nexperia product is suitable and fit for the customer's applications and products planned, as well as for the planned application and use of customer's third party customer(s). Customers should provide appropriate design and operating safeguards to minimize the risks associated with their applications and products.

Nexperia does not accept any liability related to any default, damage, costs or problem which is based on any weakness or default in the customer's applications or products, or the application or use by customer's third party customer(s). Customer is responsible for doing all necessary testing for the customer's applications and products using Nexperia products in order to avoid a default of the applications and the products or of the application or use by customer's third party customer(s). Nexperia does not accept any liability in this respect.

Limiting values — Stress above one or more limiting values (as defined in the Absolute Maximum Ratings System of IEC 60134) will cause permanent damage to the device. Limiting values are stress ratings only and (proper) operation of the device at these or any other conditions above those given in the Recommended operating conditions section (if present) or the Characteristics sections of this document is not warranted. Constant or repeated exposure to limiting values will permanently and irreversibly affect the quality and reliability of the device.

Terms and conditions of commercial sale — Nexperia products are sold subject to the general terms and conditions of commercial sale, as published at <http://www.nexperia.com/profile/terms>, unless otherwise agreed in a valid written individual agreement. In case an individual agreement is concluded only the terms and conditions of the respective agreement shall apply. Nexperia hereby expressly objects to applying the customer's general terms and conditions with regard to the purchase of Nexperia products by customer.

No offer to sell or license — Nothing in this document may be interpreted or construed as an offer to sell products that is open for acceptance or the grant, conveyance or implication of any license under any copyrights, patents or other industrial or intellectual property rights.

Export control — This document as well as the item(s) described herein may be subject to export control regulations. Export might require a prior authorization from competent authorities.

Non-automotive qualified products — Unless this data sheet expressly states that this specific Nexperia product is automotive qualified, the product is not suitable for automotive use. It is neither qualified nor tested in accordance with automotive testing or application requirements. Nexperia accepts no liability for inclusion and/or use of non-automotive qualified products in automotive equipment or applications.

In the event that customer uses the product for design-in and use in automotive applications to automotive specifications and standards, customer (a) shall use the product without Nexperia's warranty of the product for such automotive applications, use and specifications, and (b) whenever customer uses the product for automotive applications beyond Nexperia's specifications such use shall be solely at customer's own risk, and (c) customer fully indemnifies Nexperia for any liability, damages or failed product claims resulting from customer design and use of the product for automotive applications beyond Nexperia's standard warranty and Nexperia's product specifications.

Translations — A non-English (translated) version of a document is for reference only. The English version shall prevail in case of any discrepancy between the translated and English versions.

Trademarks

Notice: All referenced brands, product names, service names and trademarks are the property of their respective owners.

Contents

1. General description	1
2. Features and target applications	1
3. Typical application	1
4. Pinning information	2
5. Ordering information	3
6. Block Diagram	3
7. Limiting values	3
8. Recommended operating conditions	4
9. Thermal characteristics	4
10. Characteristics	4
10.1. Typical performance characteristics.....	5
11. Application information	7
11.1. Typical application.....	7
11.2. Harvesting efficiency.....	7
11.3. Power converter efficiency.....	8
11.4. Matching efficiency.....	8
11.5. Guideline for PV-cell selection.....	9
11.6. Enhanced low input power operation.....	9
11.7. Full battery protection.....	9
12. Package outline	10
13. Soldering	11
14. Revision history	12
15. Legal information	13

© Nexperia B.V. 2023. All rights reserved

For more information, please visit: <http://www.nexperia.com>

For sales office addresses, please send an email to: salesaddresses@nexperia.com

Date of release: 3 April 2023