

National Semiconductor is now part of
Texas Instruments.

Search <http://www.ti.com/> for the latest technical
information and details on our current products and services.

LM195/LM395 Ultra Reliable Power Transistors

General Description

The LM195/LM395 are fast, monolithic power integrated circuits with complete overload protection. These devices, which act as high gain power transistors, have included on the chip, current limiting, power limiting, and thermal overload protection making them virtually impossible to destroy from any type of overload. In the standard TO-3 transistor power package, the LM195 will deliver load currents in excess of 1.0A and can switch 40V in 500 ns.

The inclusion of thermal limiting, a feature not easily available in discrete designs, provides virtually absolute protection against overload. Excessive power dissipation or inadequate heat sinking causes the thermal limiting circuitry to turn off the device preventing excessive heating.

The LM195 offers a significant increase in reliability as well as simplifying power circuitry. In some applications, where protection is unusually difficult, such as switching regulators, lamp or solenoid drivers where normal power dissipation is low, the LM195 is especially advantageous.

The LM195 is easy to use and only a few precautions need be observed. Excessive collector to emitter voltage can destroy the LM195 as with any power transistor. When the device is used as an emitter follower with low source imped-

ance, it is necessary to insert a 5.0k resistor in series with the base lead to prevent possible emitter follower oscillations. Although the device is usually stable as an emitter follower, the resistor eliminates the possibility of trouble without degrading performance. Finally, since it has good high frequency response, supply bypassing is recommended.

For low-power applications (under 100 mA), refer to the LP395 Ultra Reliable Power Transistor.

The LM195/LM395 are available in the standard TO-3, Kovar TO-5, and TO-220 packages. The LM195 is rated for operation from -55°C to $+150^{\circ}\text{C}$ and the LM395 from 0°C to $+125^{\circ}\text{C}$.

Features

- Internal thermal limiting
- Greater than 1.0A output current
- 3.0 μA typical base current
- 500 ns switching time
- 2.0V saturation
- Base can be driven up to 40V without damage
- Directly interfaces with CMOS or TTL
- 100% electrical burn-in

Simplified Circuit

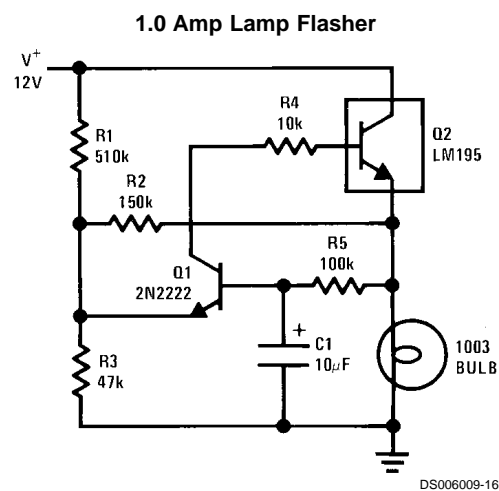
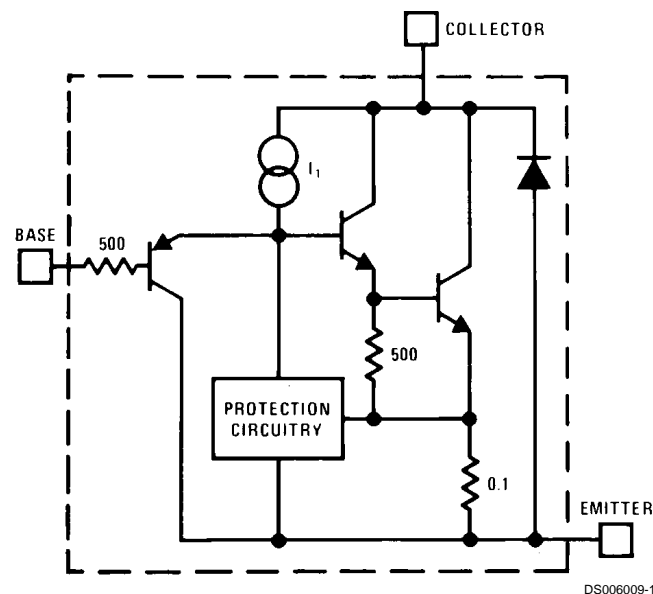

Connection Diagrams

TO-3 Metal Can Package

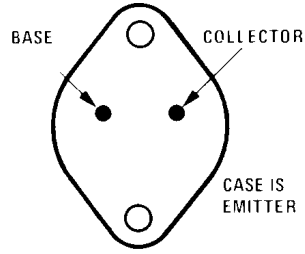

DS006009-2

Bottom View
Order Number LM195K/883
See NS Package Number K02A
 (Note 5)

TO-220 Plastic Package

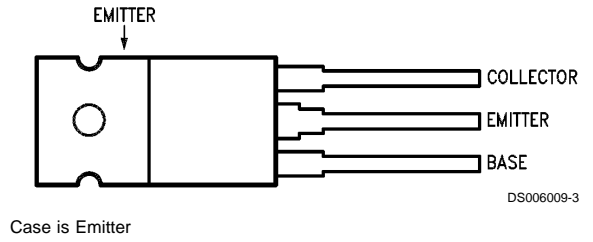

DS006009-3

Top View
Order Number LM395T
See NS Package Number T03B

TO-5 Metal Can Package

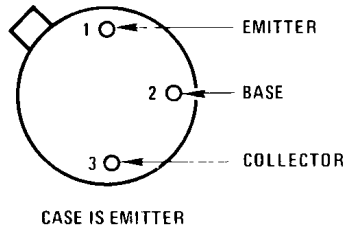

DS006009-4

Bottom View
Order Number LM195H/883
See NS Package Number H03B
 (Note 5)

Absolute Maximum Ratings (Note 1)

If Military/Aerospace specified devices are required, please contact the National Semiconductor Sales Office/Distributors for availability and specifications.

Collector to Emitter Voltage

LM195	42V
LM395	36V

Collector to Base Voltage

LM195	42V
LM395	36V

Base to Emitter Voltage (Forward)

LM195	42V
LM395	36V

Base to Emitter Voltage (Reverse)

20V

Collector Current

Internally Limited

Power Dissipation

Internally Limited

Operating Temperature Range

LM195	-55°C to +150°C
LM395	0°C to +125°C

Storage Temperature Range

-65°C to +150°C

Lead Temperature

(Soldering, 10 sec.) 260°C

Preconditioning

100% Burn-In In Thermal Limit

Electrical Characteristics

(Note 2)

Parameter	Conditions	LM195			LM395			Units
		Min	Typ	Max	Min	Typ	Max	
Collector-Emitter Operating Voltage (Note 4)	$I_Q \leq I_C \leq I_{MAX}$			42			36	V
Base to Emitter Breakdown Voltage	$0 \leq V_{CE} \leq V_{CEMAX}$	42			36	60		V
Collector Current								A
TO-3, TO-220	$V_{CE} \leq 15V$	1.2	2.2		1.0	2.2		A
TO-5	$V_{CE} \leq 7.0V$	1.2	1.8		1.0	1.8		A
Saturation Voltage	$I_C \leq 1.0A, T_A = 25^\circ C$		1.8	2.0		1.8	2.2	V
Base Current	$0 \leq I_C \leq I_{MAX}$ $0 \leq V_{CE} \leq V_{CEMAX}$		3.0	5.0		3.0	10	μA
Quiescent Current (I_Q)	$V_{be} = 0$ $0 \leq V_{CE} \leq V_{CEMAX}$		2.0	5.0		2.0	10	mA
Base to Emitter Voltage	$I_C = 1.0A, T_A = +25^\circ C$		0.9			0.9		V
Switching Time	$V_{CE} = 36V, R_L = 36\Omega,$ $T_A = 25^\circ C$		500			500		ns
Thermal Resistance Junction to Case (Note 3)	TO-3 Package (K)		2.3	3.0		2.3	3.0	$^\circ C/W$
	TO-5 Package (H)		12	15		12	15	$^\circ C/W$
	TO-220 Package (T)					4	6	$^\circ C/W$

Note 1: "Absolute Maximum Ratings" indicate limits beyond which damage to the device may occur. Operating Ratings indicate conditions for which the device is functional, but do not guarantee specific performance limits.

Note 2: Unless otherwise specified, these specifications apply for $-55^\circ C \leq T_j \leq +150^\circ C$ for the LM195 and $0^\circ C \leq +125^\circ C$ for the LM395.

Note 3: Without a heat sink, the thermal resistance of the TO-5 package is about $+150^\circ C/W$, while that of the TO-3 package is $+35^\circ C/W$.

Note 4: Selected devices with higher breakdown available.

Note 5: Refer to RETS195H and RETS195K drawings of military LM195H and LM195K versions for specifications.

Typical Performance Characteristics (for K and T Packages)

Collector Characteristics

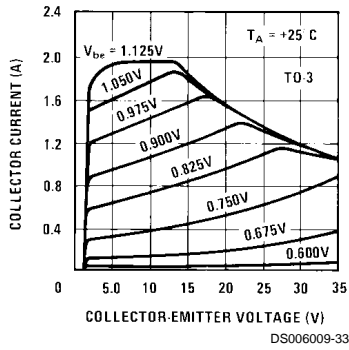

Short Circuit Current

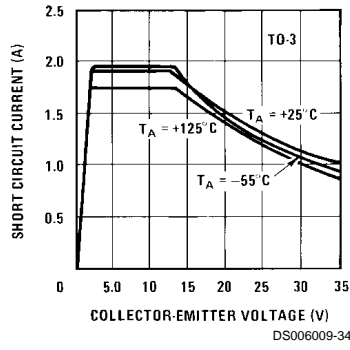

Bias Current

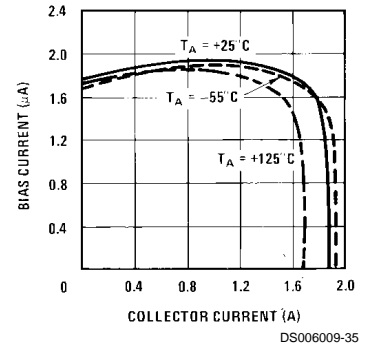

Quiescent Current

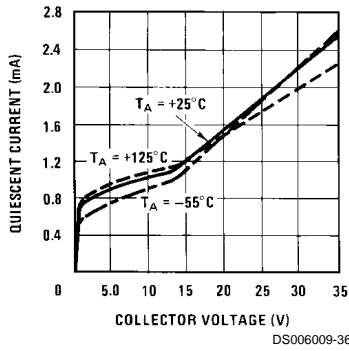

Base Emitter Voltage

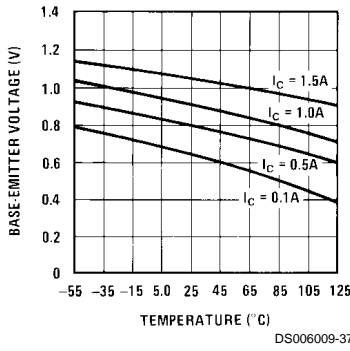

Base Current

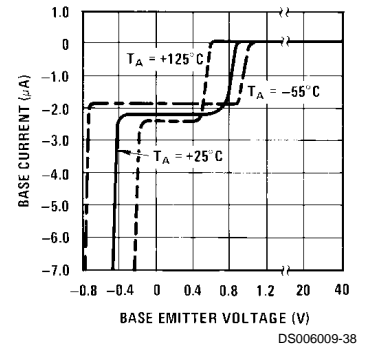

Saturation Voltage

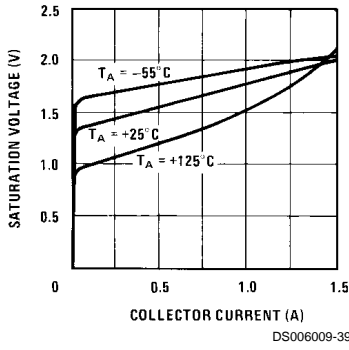

Response Time

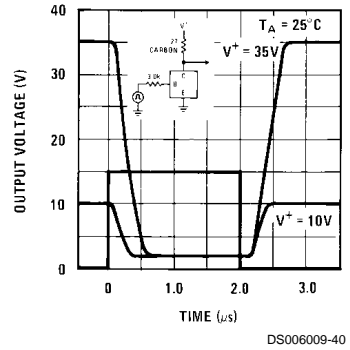

Response Time

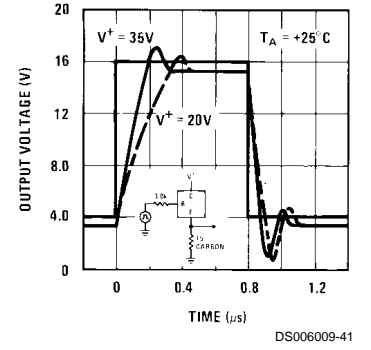

Typical Performance Characteristics (for K and T Packages) (Continued)

10V Transfer Function

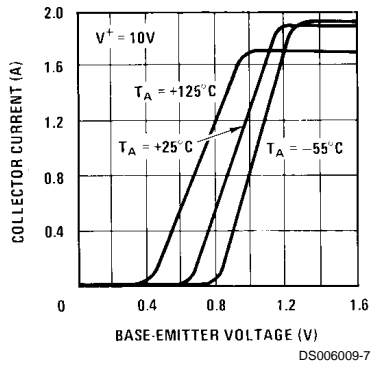

36V Transfer Function

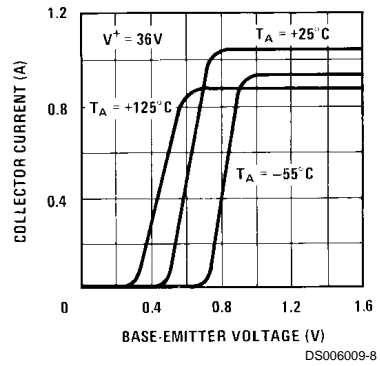

Transconductance

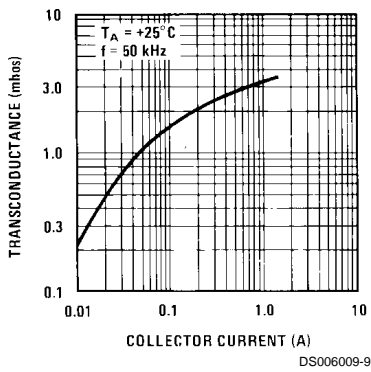

Small Signal Frequency Response

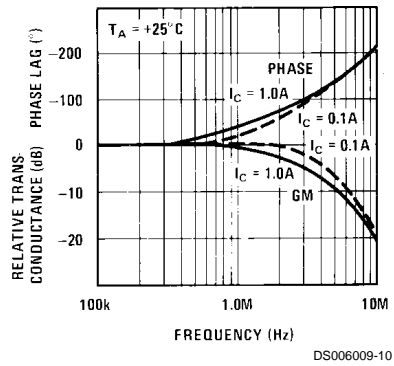

Schematic Diagram

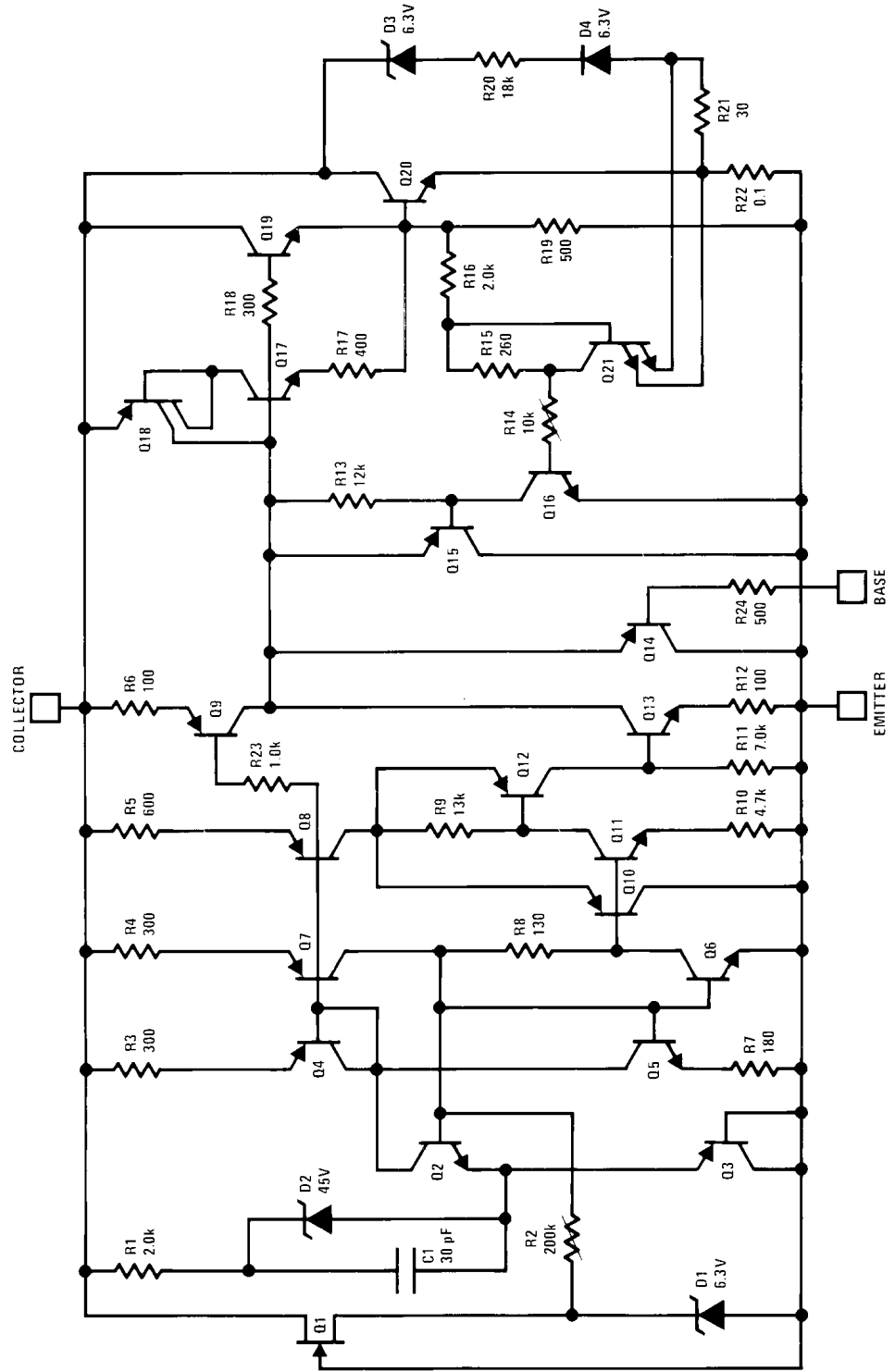

DS006008-11

Typical Applications

1.0 Amp Voltage Follower

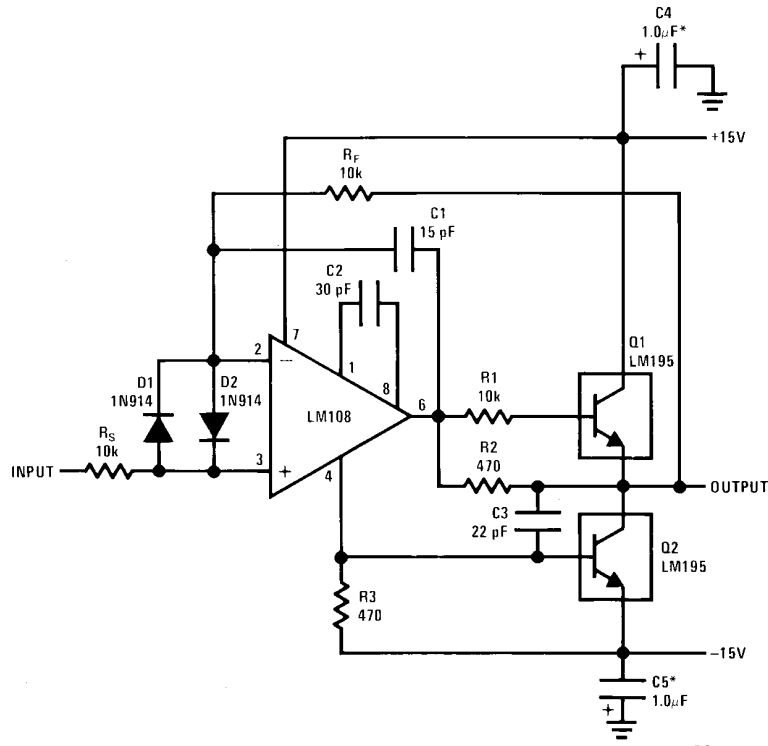

DS006009-12

*Solid Tantalum

Power PNP

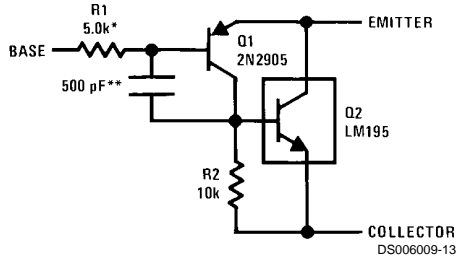

DS006009-13

*Protects against excessive base drive
**Needed for stability

Time Delay

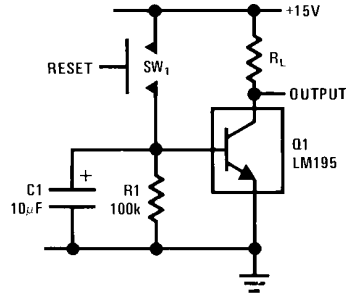

DS006009-14

1.0 MHz Oscillator

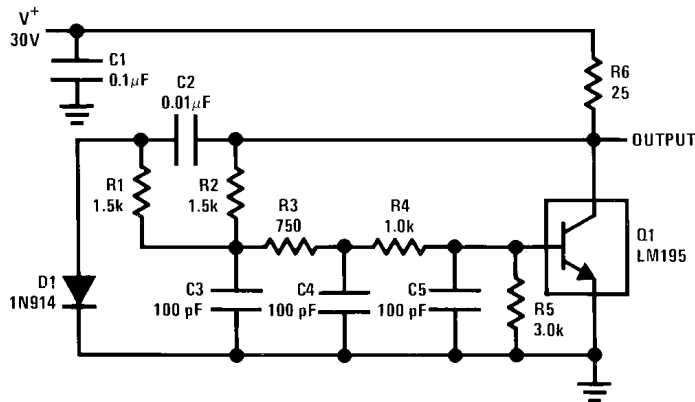

DS006009-15

Typical Applications (Continued)

1.0 Amp Negative Regulator

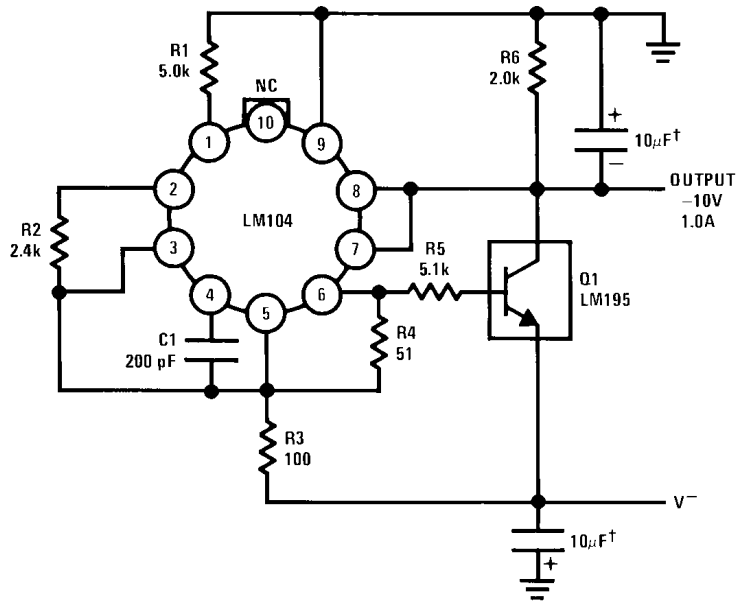

DS006009-17

†Solid Tantalum

1.0 Amp Positive Voltage Regulator

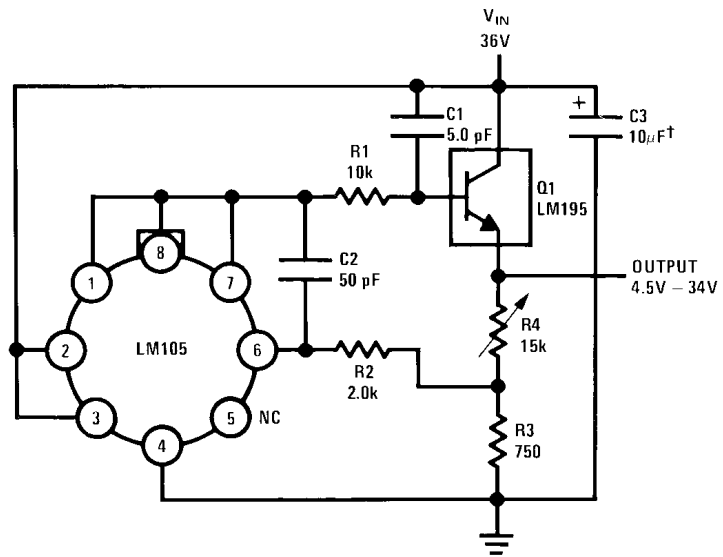

DS006009-18

†Solid Tantalum

Typical Applications (Continued)

Fast Optically Isolated Switch

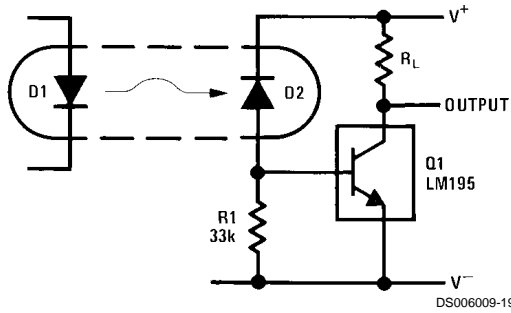

Optically Isolated Power Transistor

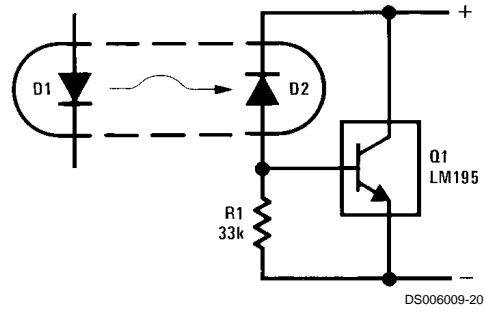

CMOS or TTL Lamp Interface

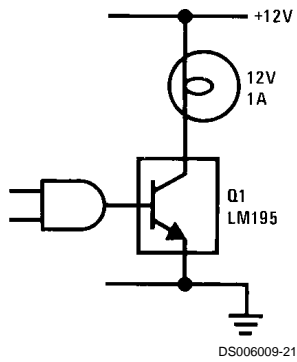

Two Terminal Current Limiter

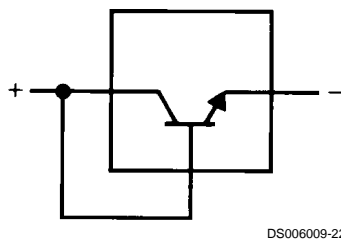

40V Switch

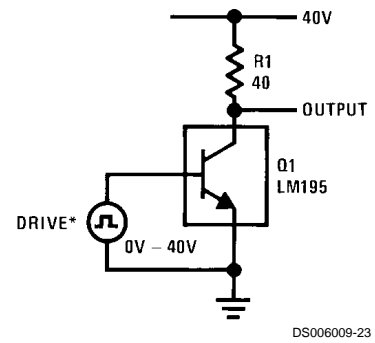

*Drive Voltage 0V to $\geq 10V \leq 42V$

6.0V Shunt Regulator with Crowbar

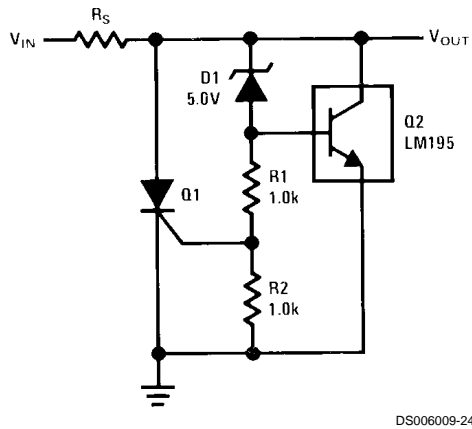

Two Terminal 100 mA Current Regulator

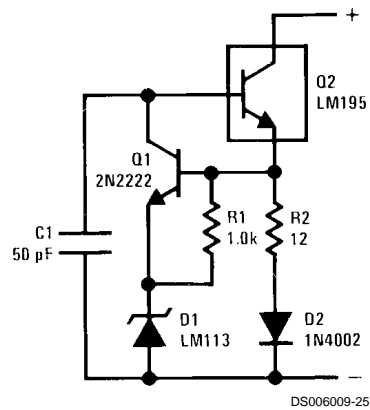

Typical Applications (Continued)

Low Level Power Switch

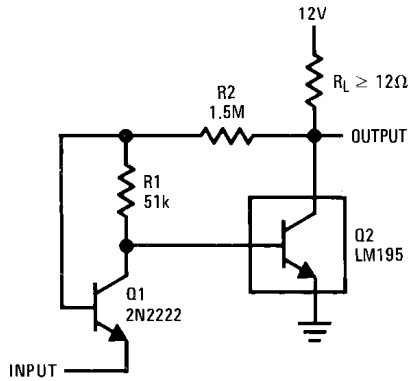

DS006009-26

Turn ON = 350 mV
Turn OFF = 200 mV

Power One-Shot

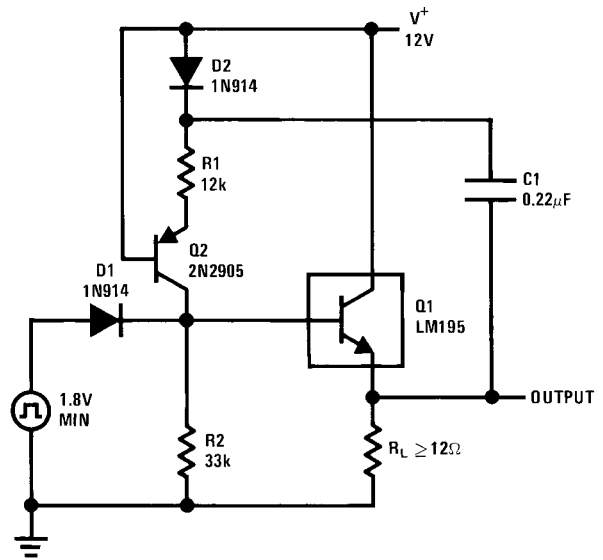

DS006009-27

$T = R1C$
 $R2 = 3R1$
 $R2 \leq 82k$

Emitter Follower

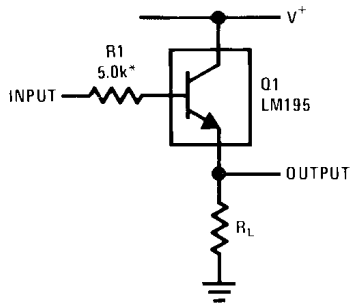

DS006009-28

*Need for Stability

High Input Impedance AC Emitter Follower

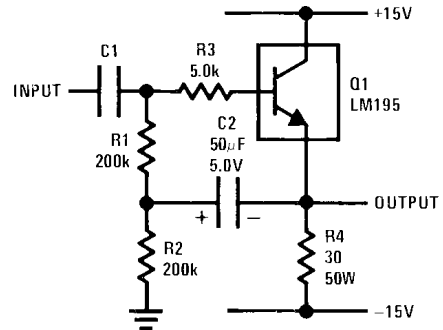

DS006009-29

Fast Follower

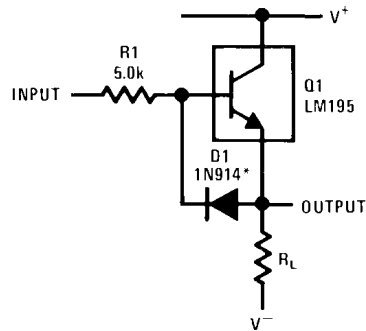

DS006009-30

*Prevents storage with fast fall time square wave drive

Typical Applications (Continued)

Power Op Amp

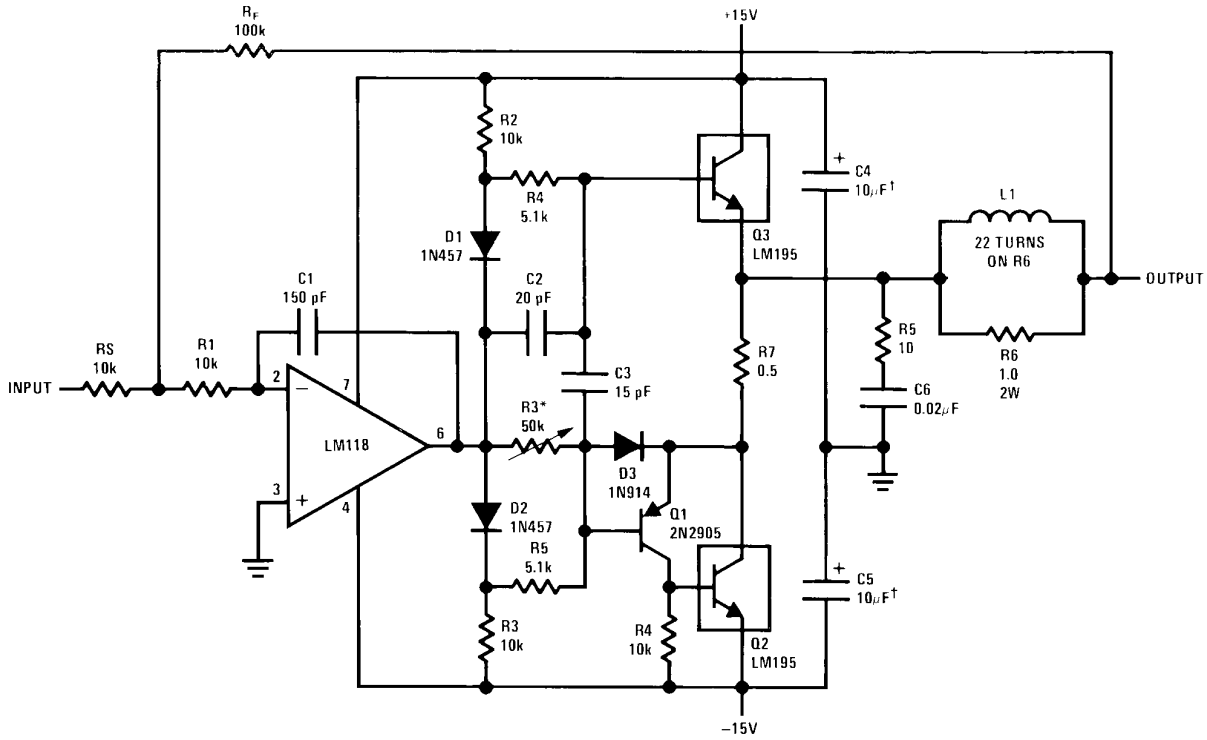

DS006009-31

*Adjust for 50 mA quiescent current
 †Solid Tantalum

6.0 Amp Variable Output Switching Regulator

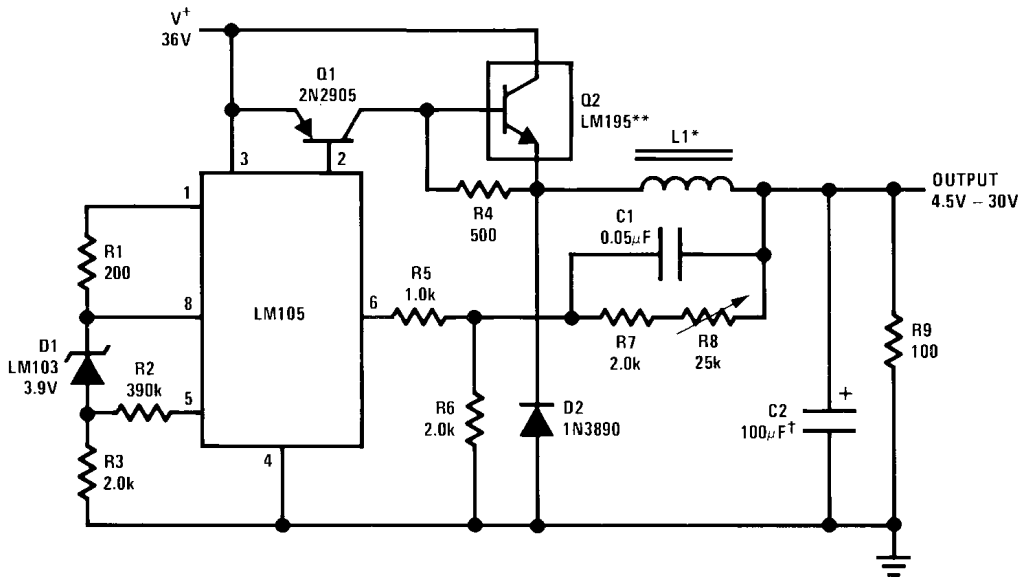

DS006009-32

*Sixty turns wound on Arnold Type A-083081-2 core.
 **Four devices in parallel
 †Solid tantalum

Physical Dimensions inches (millimeters) unless otherwise noted

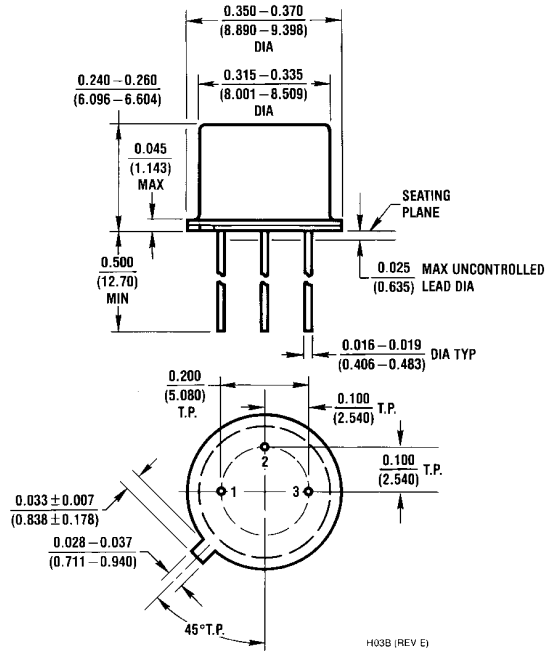

TO-5 Metal Can Package
Order Number LM195H/883
NS Package Number H03B

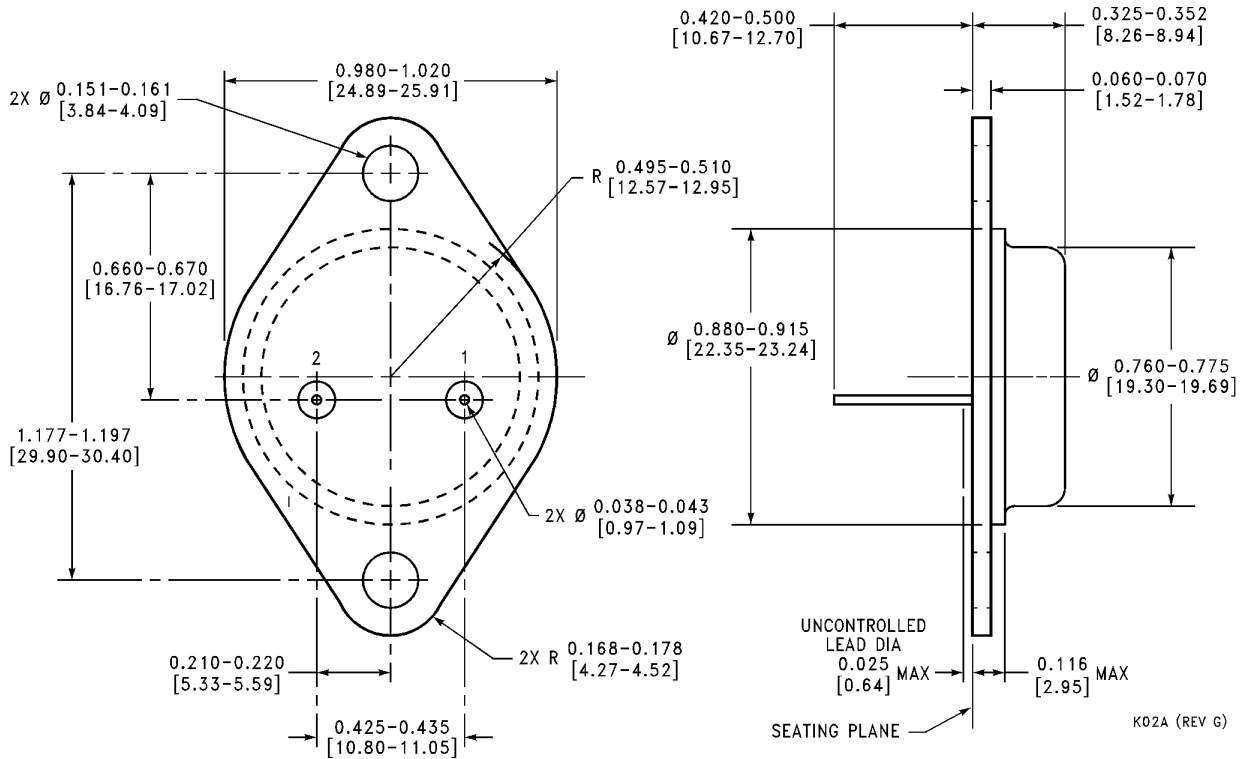

TO-3 Metal Can Package
Order Number LM195K/883
NS Package Number K02A

Physical Dimensions inches (millimeters) unless otherwise noted (Continued)

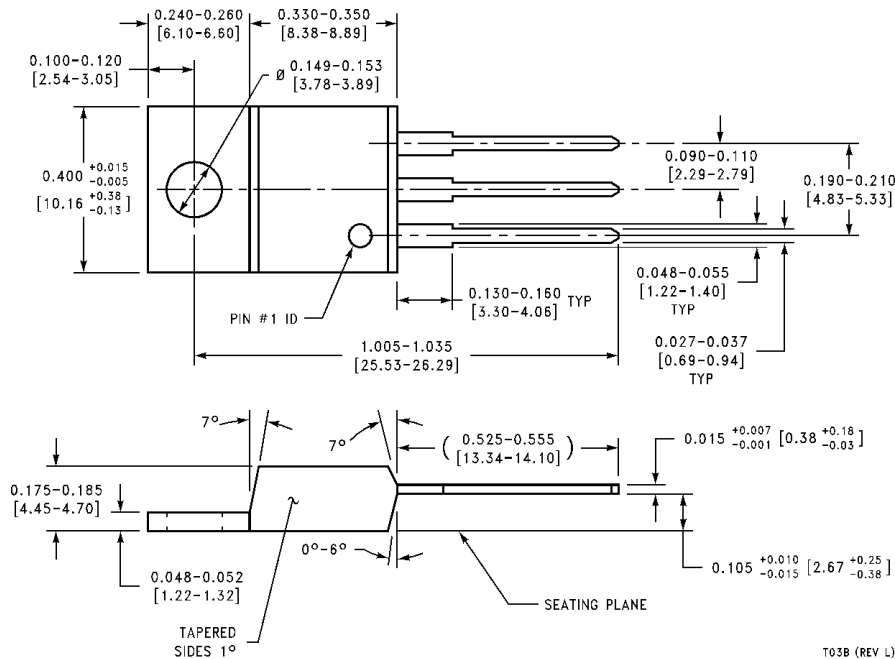

**TO-220 Plastic Package
Order Number LM395T
NS Package Number T03B**

LIFE SUPPORT POLICY

NATIONAL'S PRODUCTS ARE NOT AUTHORIZED FOR USE AS CRITICAL COMPONENTS IN LIFE SUPPORT DEVICES OR SYSTEMS WITHOUT THE EXPRESS WRITTEN APPROVAL OF THE PRESIDENT AND GENERAL COUNSEL OF NATIONAL SEMICONDUCTOR CORPORATION. As used herein:

1. Life support devices or systems are devices or systems which, (a) are intended for surgical implant into the body, or (b) support or sustain life, and whose failure to perform when properly used in accordance with instructions for use provided in the labeling, can be reasonably expected to result in a significant injury to the user.
2. A critical component is any component of a life support device or system whose failure to perform can be reasonably expected to cause the failure of the life support device or system, or to affect its safety or effectiveness.



National Semiconductor Corporation
Americas
Tel: 1-800-272-9959
Fax: 1-800-737-7018
Email: support@nsc.com
www.national.com

National Semiconductor Europe
Fax: +49 (0) 180-530 85 86
Email: europe.support@nsc.com
Deutsch Tel: +49 (0) 69 9508 6208
English Tel: +44 (0) 870 24 0 2171
Français Tel: +33 (0) 1 41 91 8790

National Semiconductor Asia Pacific Customer Response Group
Tel: 65-2544466
Fax: 65-2504466
Email: ap.support@nsc.com

National Semiconductor Japan Ltd.
Tel: 81-3-5639-7560
Fax: 81-3-5639-7507

[Products](#) > [Analog - Other](#) > [Motor Control/ Switches/ Current Drivers](#) > [Transistors, Current Drivers, etc.](#) > LM395

LM395 Product Folder

Ultra Reliable Power Transistor

[General Description](#)

[Features](#)

[Datasheet](#)

[Package & Models](#)

[Samples & Pricing](#)

[Application Notes](#)

Parametric Table

Parametric Table

Function	Ultra Reliable Power Transistor
----------	---------------------------------

Datasheet

Title	Size in Kbytes	Date	View Online	Download	Receive via Email
LM195 LM395 Ultra Reliable Power Transistors	420 Kbytes	23-Aug-00	View Online	Download	Receive via Email

If you have trouble printing or viewing PDF file(s), see [Printing Problems](#).

Package Availability, Models, Samples & Pricing

Part Number	Package			Status	Models		Samples & Electronic Orders	Budgetary Pricing		Std Pack Size	Package Marking
	Type	Pins	MSL		SPICE	IBIS		Qty	\$US each		
LM395T	TO 220	3	MSL	Full production	N/A	N/A	Buy Now	1K+	\$1.4900	rail of 45	[logo]UçZç2çT LM395T
LM395 MDC	Die			Full production	N/A	N/A	Samples			tray of N/A	-
LM395 MWC	Wafer			Full production	N/A	N/A				wafer jar of N/A	-

General Description

The LM195/LM395 are fast, monolithic power integrated circuits with complete overload protection. These devices, which act as high gain power transistors, have included on the chip, current limiting, power limiting, and thermal overload protection making them virtually impossible to destroy from any type of overload. In the standard TO-3 transistor power package, the LM195 will deliver load currents in excess of 1.0A and can switch 40V in 500 ns.

The inclusion of thermal limiting, a feature not easily available in discrete designs, provides virtually absolute protection against overload. Excessive power dissipation or inadequate heat sinking causes the thermal limiting circuitry to turn off the device preventing excessive heating.

The LM195 offers a significant increase in reliability as well as simplifying power circuitry. In some applications, where protection is unusually difficult, such as switching regulators, lamp or solenoid drivers where normal power dissipation is low, the LM195 is especially advantageous.

The LM195 is easy to use and only a few precautions need be observed. Excessive collector to emitter voltage can destroy the LM195 as with any power transistor. When the device is used as an emitter follower with low source impedance, it is necessary to insert a 5.0k resistor in series with the base lead to prevent possible emitter follower oscillations. Although the device is usually stable as an emitter follower, the resistor eliminates the possibility of trouble without degrading performance. Finally, since it has good high frequency response, supply bypassing is recommended.

For low-power applications (under 100 mA), refer to the LP395 Ultra Reliable Power Transistor.

The LM195/LM395 are available in the standard TO-3, Kovar TO-5, and TO-220 packages. The LM195 is rated for operation from -55°C to +150°C and the LM395 from 0°C to +125°C.

Features

- Internal thermal limiting
- Greater than 1.0A output current
- 3.0 μ A typical base current
- 500 ns switching time
- 2.0V saturation
- Base can be driven up to 40V without damage
- Directly interfaces with CMOS or TTL
- 100% electrical burn-in

Application Notes

Title	Size in Kbytes	Date	<input type="checkbox"/> View Online	<input type="checkbox"/> Download	<input type="checkbox"/> Receive via Email
AN-110: Application Note 110 Fast IC Power Transistor with Thermal Protection	333 Kbytes	1-May-98	View Online	Download	Receive via Email
AN-161: IC Voltage Reference has 1 ppm per Degree Drift	133 Kbytes	4-Nov-95	View Online	Download	Receive via Email
AN-173: IC Zener Eases Reference Design	77 Kbytes	4-Nov-95	View Online	Download	Receive via Email
AN-181: Application Note 181 3-Terminal Regulator Is Adjustable	123 Kbytes	8-Nov-00	View Online	Download	Receive via Email

AN-262: Applying Dual and Quad FET Op Amps	177 Kbytes	10- May- 96	View Online	Download	Receive via Email
AN-293: Control Applications of CMOS DACs	178 Kbytes	4- Nov- 95	View Online	Download	Receive via Email
AN-460: LM34/LM35 Precision Monolithic Temperature Sensors	190 Kbytes	4- Nov- 95	View Online	Download	Receive via Email
LM34/LM35 Precision Monolithic Temperature Sensors (JAPANESE)	322 Kbytes		View Online	Download	Receive via
LB-28: Linear Brief 28 General Purpose Power Supply	45 Kbytes	1- May- 98	View Online	Download	Receive via Email

If you have trouble printing or viewing PDF file(s), see [Printing Problems](#).

[Information as of 5-Aug-2002]

Search

[Design](#)

[Purchasing](#)

[Quality](#)

[Company](#)

[Home](#)

[About Languages](#) . [Website Guide](#) . [About "Cookies"](#) . National is [QS 9000 Certified](#) . [Privacy/Security Statement](#) .
[Contact Us](#) . [Site Terms & Conditions of Use](#) . Copyright 2002 © National Semiconductor Corporation . [My Preferences](#) .
[Feedback](#)

[Products](#) > [Analog - Other](#) > [Motor Control/ Switches/ Current Drivers](#) > [Transistors, Current Drivers, etc.](#) > LM195

LM195 Product Folder

Ultra Reliable Power Transistor

General Description	Features	Datasheet	Package & Models	Samples & Pricing	Application Notes
-------------------------------------	--------------------------	---------------------------	--------------------------------------	---------------------------------------	-----------------------------------

Parametric Table

Parametric Table

Function	Ultra Reliable Power Transistor
----------	---------------------------------

Datasheet

Title	Size in Kbytes	Date	View Online	Download	Receive via Email
LM195 LM395 Ultra Reliable Power Transistors	420 Kbytes	23-Aug-00	View Online	Download	Receive via Email
LM195 Mil-Aero Datasheet MNLM195-H	14 Kbytes		View Online	Download	Receive via Email
LM195 Mil-Aero Datasheet MNLM195-K	9 Kbytes		View Online	Download	Receive via Email

If you have trouble printing or viewing PDF file(s), see [Printing Problems](#).

Package Availability, Models, Samples & Pricing

Part Number	Package			Status	Models		Samples & Electronic Orders	Budgetary Pricing		Std Pack Size	Package Marking
	Type	Pins	MSL		SPICE	IBIS		Qty	\$US each		
5962-8777801XA	TO-39	3	MSL	Full production	N/A	N/A	Buy Now	50+	\$16.0000	tray of 20	[logo] ϕ Z ϕ S ϕ 4 ϕ A LM195H/883Q ϕ M 5962-8777801XA \$E
5962-8777801YA	TO-3	2	MSL	Full production	N/A	N/A	Buy Now	50+	\$19.2000	tray of 50	[logo] ϕ Z ϕ S ϕ 4 ϕ A LM195K/883Q ϕ M \$E5962-8777801YA
LM195K MD8	Die			Full production	N/A	N/A	Samples			tray of N/A	-
LM195H MD8	Wafer			Full production	N/A	N/A				wafer jar of N/A	-

LM195H MW8	Wafer	Full production	N/A	N/A				wafer jar of N/A	-
LM195K MW8	Wafer	Full production	N/A	N/A				wafer jar of N/A	-

General Description

The LM195/LM395 are fast, monolithic power integrated circuits with complete overload protection. These devices, which act as high gain power transistors, have included on the chip, current limiting, power limiting, and thermal overload protection making them virtually impossible to destroy from any type of overload. In the standard TO-3 transistor power package, the LM195 will deliver load currents in excess of 1.0A and can switch 40V in 500 ns.

The inclusion of thermal limiting, a feature not easily available in discrete designs, provides virtually absolute protection against overload. Excessive power dissipation or inadequate heat sinking causes the thermal limiting circuitry to turn off the device preventing excessive heating.

The LM195 offers a significant increase in reliability as well as simplifying power circuitry. In some applications, where protection is unusually difficult, such as switching regulators, lamp or solenoid drivers where normal power dissipation is low, the LM195 is especially advantageous.

The LM195 is easy to use and only a few precautions need be observed. Excessive collector to emitter voltage can destroy the LM195 as with any power transistor. When the device is used as an emitter follower with low source impedance, it is necessary to insert a 5.0k resistor in series with the base lead to prevent possible emitter follower oscillations. Although the device is usually stable as an emitter follower, the resistor eliminates the possibility of trouble without degrading performance. Finally, since it has good high frequency response, supply bypassing is recommended.

For low-power applications (under 100 mA), refer to the LP395 Ultra Reliable Power Transistor.

The LM195/LM395 are available in the standard TO-3, Kovar TO-5, and TO-220 packages. The LM195 is rated for operation from -55°C to +150°C and the LM395 from 0°C to +125°C.

Features

- Internal thermal limiting
- Greater than 1.0A output current
- 3.0 µA typical base current
- 500 ns switching time
- 2.0V saturation
- Base can be driven up to 40V without damage
- Directly interfaces with CMOS or TTL
- 100% electrical burn-in

Application Notes

Title	Size in Kbytes	Date	<input type="checkbox"/>	<input type="checkbox"/>	<input type="checkbox"/>
			View Online	Download	Receive via Email

AN-110: Application Note 110 Fast IC Power Transistor with Thermal Protection	333 Kbytes	1-May-98	View Online	Download	Receive via Email
---	------------	----------	-----------------------------	--------------------------	-----------------------------------

If you have trouble printing or viewing PDF file(s), see [Printing Problems](#).

[Information as of 5-Aug-2002]

Search

[Design](#)

[Purchasing](#)

[Quality](#)

[Company](#)

[Home](#)

[About Languages](#) . [Website Guide](#) . [About "Cookies"](#) . National is [QS 9000 Certified](#) . [Privacy/Security Statement](#) .
[Contact Us](#) . [Site Terms & Conditions of Use](#) . Copyright 2002 © National Semiconductor Corporation . [My Preferences](#) .
[Feedback](#)