

Important notice

Dear Customer,

On 7 February 2017 the former NXP Standard Product business became a new company with the tradename **Nexperia**. Nexperia is an industry leading supplier of Discrete, Logic and PowerMOS semiconductors with its focus on the automotive, industrial, computing, consumer and wearable application markets

In data sheets and application notes which still contain NXP or Philips Semiconductors references, use the references to Nexperia, as shown below.

Instead of <http://www.nxp.com>, <http://www.philips.com/> or <http://www.semiconductors.philips.com/>, use <http://www.nexperia.com>

Instead of sales.addresses@www.nxp.com or sales.addresses@www.semiconductors.philips.com, use salesaddresses@nexperia.com (email)

Replace the copyright notice at the bottom of each page or elsewhere in the document, depending on the version, as shown below:

- © NXP N.V. (year). All rights reserved or © Koninklijke Philips Electronics N.V. (year). All rights reserved

Should be replaced with:

- © **Nexperia B.V. (year). All rights reserved.**

If you have any questions related to the data sheet, please contact our nearest sales office via e-mail or telephone (details via salesaddresses@nexperia.com). Thank you for your cooperation and understanding,

Kind regards,

Team Nexperia

74LVT16374A; 74LVTH16374A

3.3 V 16-bit edge-triggered D-type flip-flop; 3-state

Rev. 10 — 2 April 2012

Product data sheet

1. General description

The 74LVT16374A; 74LVTH16374A are high performance BiCMOS products designed for V_{CC} operation at 3.3 V.

This device is a 16-bit edge-triggered D-type flip-flop featuring non-inverting 3-state outputs. The device can be used as two 8-bit flip-flops or one 16-bit flip-flop. On the positive transition of the clock (nCP), the nQn outputs of the flip-flop take on the logic levels set up at the nDn inputs.

2. Features and benefits

- 16-bit edge-triggered flip-flop
- 3-state buffers
- Output capability: +64 mA and -32 mA
- TTL input and output switching levels
- Input and output interface capability to systems at 5 V supply
- Bus-hold data inputs eliminate the need for external pull-up resistors to hold unused inputs
- Live insertion and extraction permitted
- Power-up reset
- Power-up 3-state
- No bus current loading when output is tied to 5 V bus
- Latch-up protection:
 - ◆ JESD78B Class II exceeds 500 mA
- ESD protection:
 - ◆ HBM JESD22-A114F exceeds 2000 V
 - ◆ MM JESD22-A115-A exceeds 200 V



3. Ordering information

Table 1. Ordering information

Type number	Package			Version
	Temperature range	Name	Description	
74LVT16374ADL	-40 °C to +85 °C	SSOP48	plastic shrink small outline package; 48 leads; body width 7.5 mm	SOT370-1
74LVT16374ADGG 74LVTH16374ADGG	-40 °C to +85 °C	TSSOP48	plastic thin shrink small outline package; 48 leads; body width 6.1 mm	SOT362-1
74LVT16374AEV	-40 °C to +85 °C	VFBGA56	plastic very thin fine-pitch ball grid array package; 56 balls; body 4.5 × 7 × 0.65 mm	SOT702-1
74LVTH16374ABX	-40 °C to +125 °C	HXQFN60	plastic compatible thermal enhanced extremely thin quad flat package; no leads; 60 terminals; body 4 × 6 × 0.5 mm	SOT1134-2

4. Functional diagram

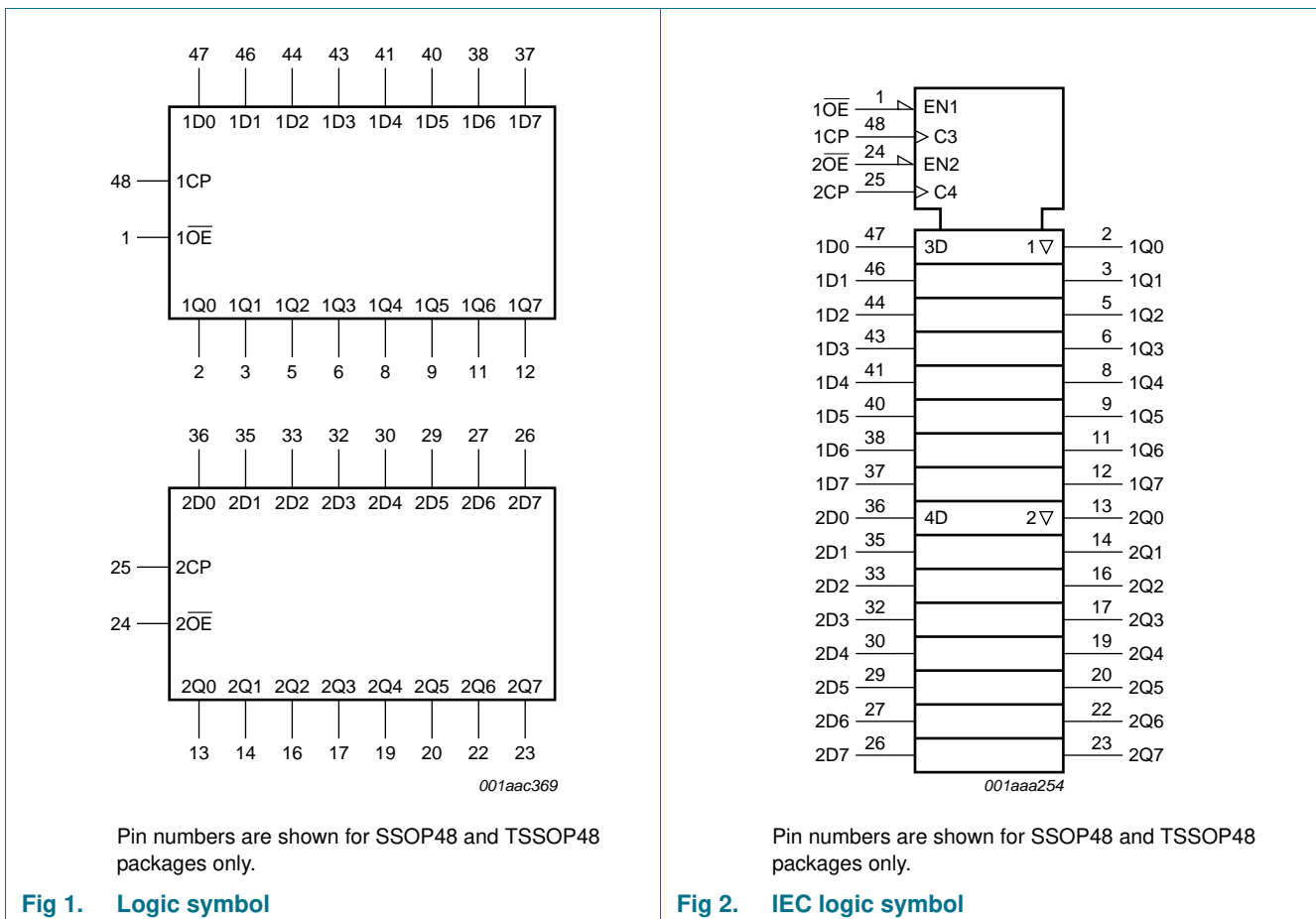

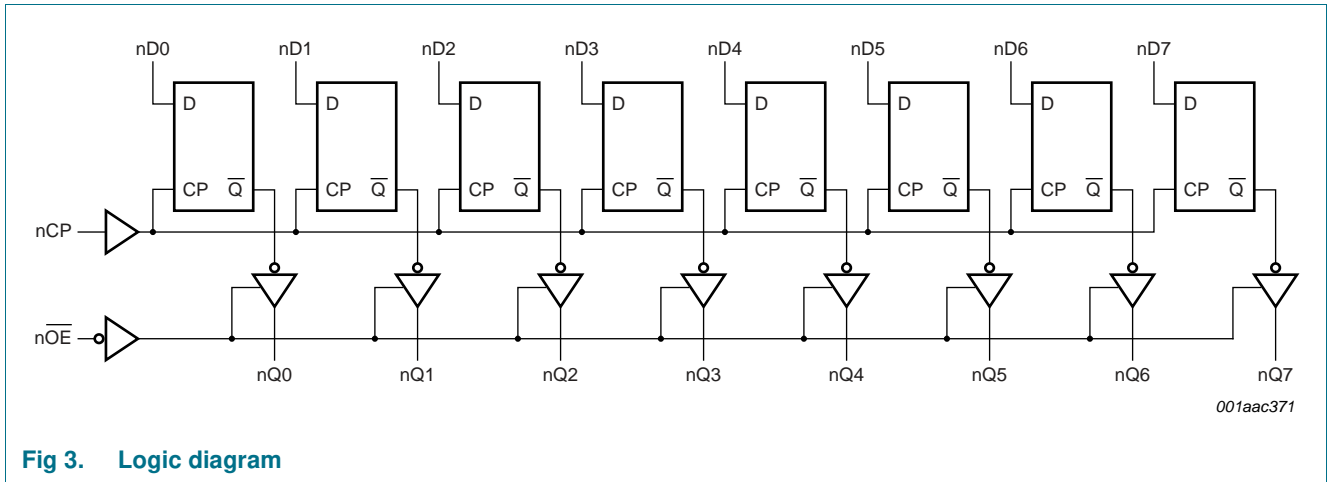

Fig 3. Logic diagram

5. Pinning information

5.1 Pinning

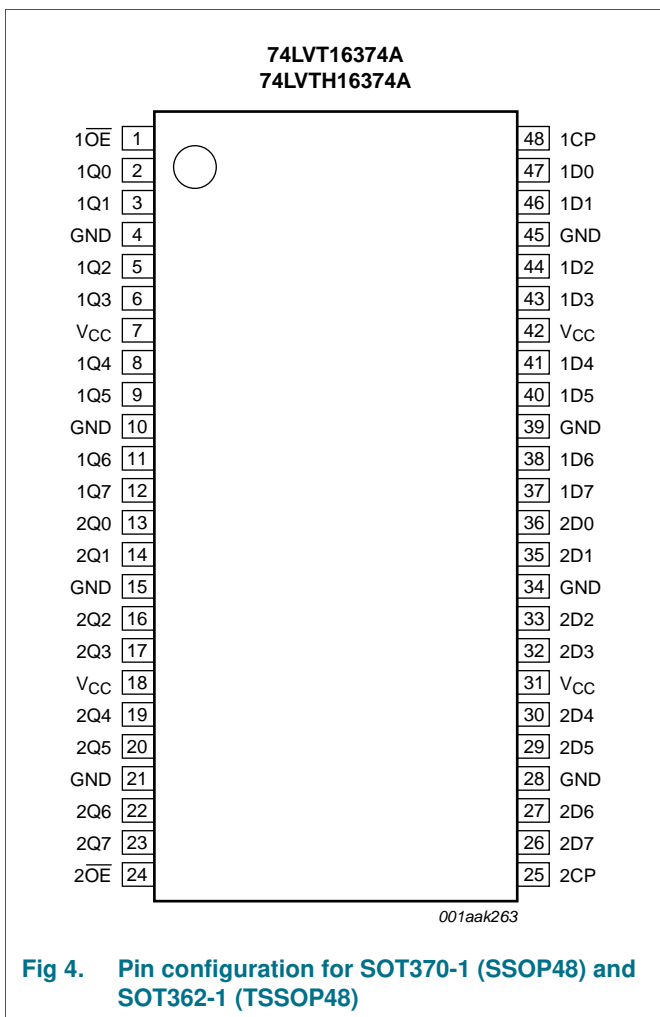

Fig 4. Pin configuration for SOT370-1 (SSOP48) and SOT362-1 (TSSOP48)

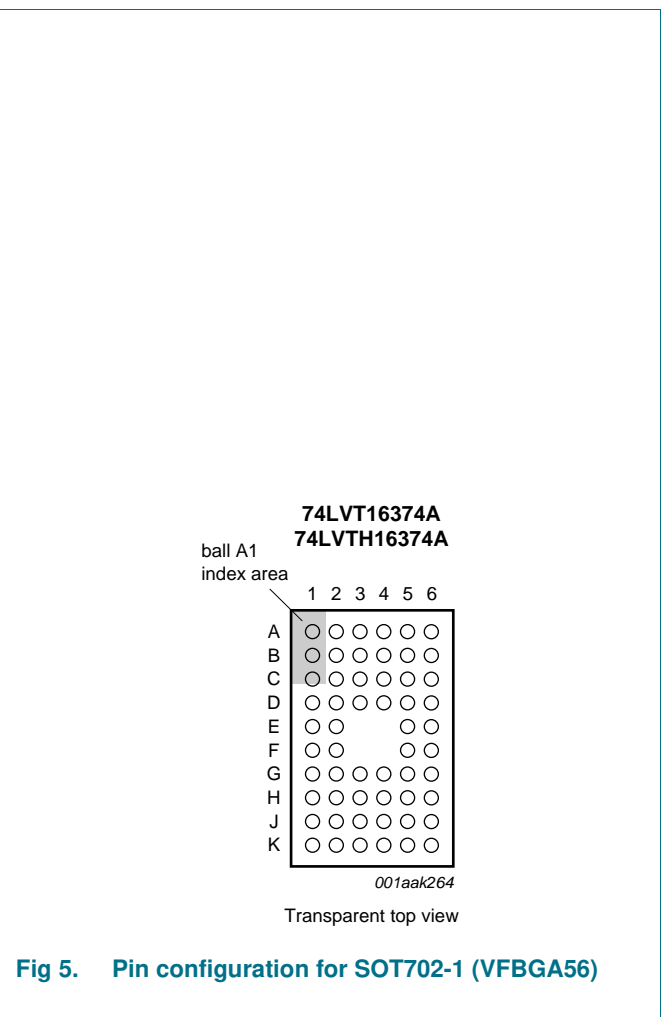
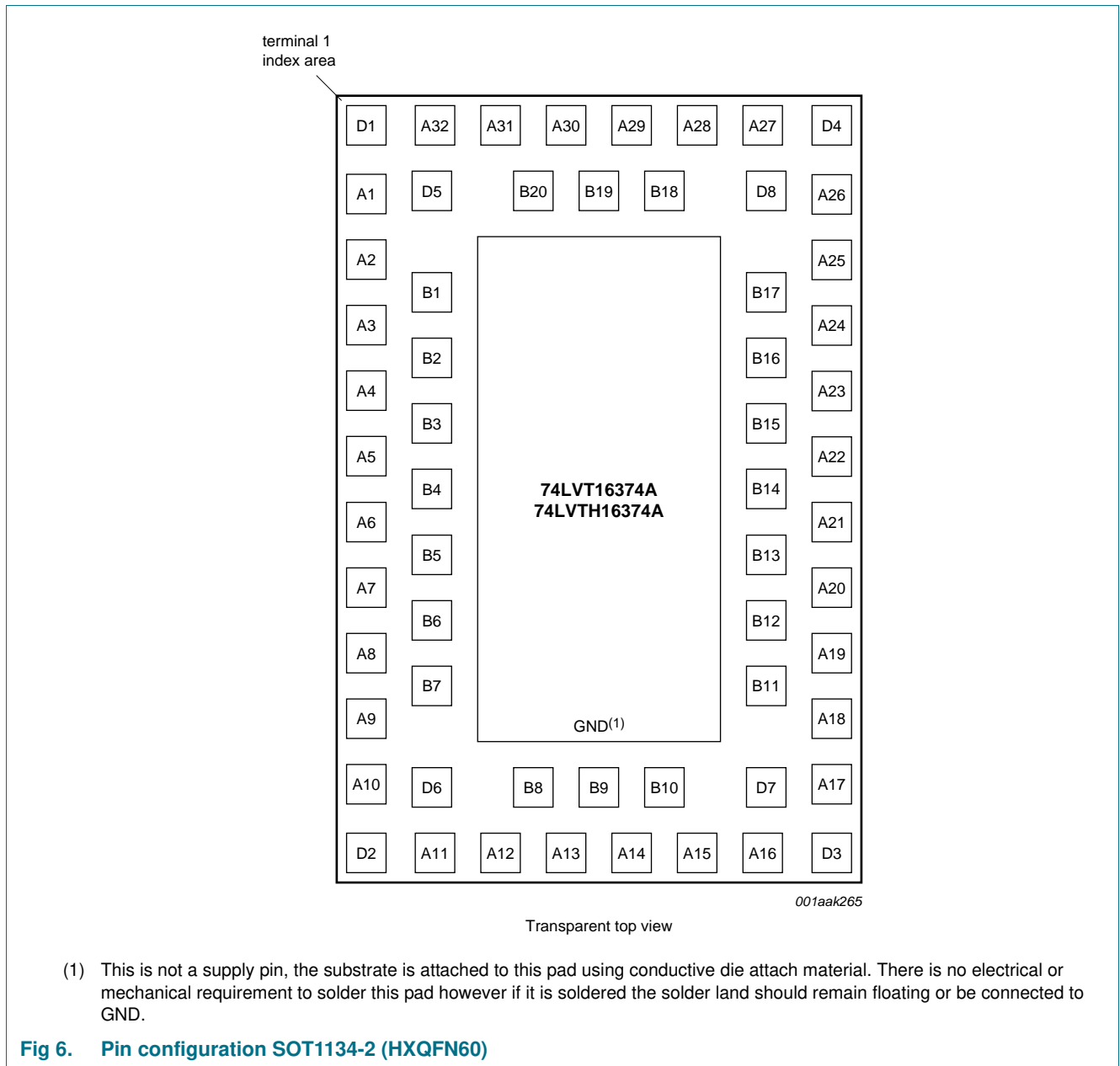

Fig 5. Pin configuration for SOT702-1 (VFPGA56)



5.2 Pin description

Table 2. Pin description

Symbol	Pin			Description
	SOT370-1 and SOT362-1	SOT702-1	SOT1134-2	
$\overline{1OE}, \overline{2OE}$	1, 24	A1, K1	A30, A13	output enable input (active LOW)
1CP, 2CP	48, 25	A6, K6	A29, A14	clock input
1Q0 to 1Q7	2, 3, 5, 6, 8, 9, 11, 12	B2, B1, C2, C1, D2, D1, E2, E1	B20, A31, D5, D1, A2, B2, B3, A5	data output
2Q0 to 2Q7	13, 14, 16, 17, 19, 20, 22, 23	F1, F2, G1, G2, H1, H2, J1, J2	A6, B5, B6, A9, D2, D6, A12, B8	data output
GND	4, 10, 15, 21, 28, 34, 39, 45	B3, D3, G3, J3, J4, G4, D4, B4	A32, A3, A8, A11, A16, A19, A24, A27	ground (0 V)
V _{CC}	7, 18, 31, 42	C3, H3, H4, C4	A1, A10, A17, A26	supply voltage
1D0 to 1D7	47, 46, 44, 43, 41, 40, 38, 37	B5, B6, C5, C6, D5, D6, E5, E6	B18, A28, D8, D4, A25, B16, B15, A22	data input
2D0 to 2D7	36, 35, 33, 32, 30, 29, 27, 26	F6, F5, G6, G5, H6, H5, J6, J5	A21, B13, B12, A18, D3, D7, A15, B10	data input
n.c.	-	A2, A3, A4, A5, K2, K3, K4, K5	A4, A7, A20, A23, B1, B4, B7, B9, B11, B14, B17, B19	not connected

6. Functional description

Table 3. Function table^[1]

Operating mode	Input			Internal register	Output nQ0 to nQ7
	nOE	nCP	nDn		
Load and read register	L	↑	l	L	L
	L	↑	h	H	H
Hold	L	NC	X	NC	NC
Disable outputs	H	NC	X	NC	Z
	H	↑	nDn	nDn	Z

- [1] H = HIGH voltage level;
h = HIGH voltage level one set-up time prior to the HIGH-to-LOW clock transition;
L = LOW voltage level;
l = LOW voltage level one set-up time prior to the HIGH-to-LOW clock transition;
NC = no change;
X = don't care;
Z = high-impedance OFF-state;
↑ = LOW-to-HIGH clock transition.

7. Limiting values

Table 4. Limiting values

In accordance with the Absolute Maximum Rating System (IEC 60134). Voltages are referenced to GND (ground = 0 V).

Symbol	Parameter	Conditions	Min	Max	Unit
V _{CC}	supply voltage		-0.5	+4.6	V
V _I	input voltage		[1] -0.5	+7.0	V
V _O	output voltage	output in OFF-state or HIGH-state	[1] -0.5	+7.0	V
I _{IK}	input clamping current	V _I < 0 V	-50	-	mA
I _{OK}	output clamping current	V _O < 0 V	-50	-	mA
I _O	output current	output in LOW-state	-	128	mA
		output in HIGH-state	-64	-	mA
T _{stg}	storage temperature		-65	+150	°C
T _j	junction temperature		[2] -	150	°C
P _{tot}	total power dissipation	T _{amb} = -40 °C to +85 °C			
		(T)SSOP48 package	[3] -	500	mW
		VFPGA56 and HXQFN60 package	[4] -	1000	mW

[1] The input and output negative voltage ratings may be exceeded if the input and output clamp current ratings are observed.

[2] The performance capability of a high-performance integrated circuit in conjunction with its thermal environment can create junction temperatures which are detrimental to reliability.

[3] Above 60 °C the value of P_{tot} derates linearly with 5.5 mW/K.

[4] Above 70 °C the value of P_{tot} derates linearly with 1.8 mW/K.

8. Recommended operating conditions

Table 5. Recommended operating conditions

Symbol	Parameter	Conditions	Min	Typ	Max	Unit
V _{CC}	supply voltage		2.7	-	3.6	V
V _I	input voltage		0	-	5.5	V
V _{IH}	HIGH-level input voltage		2.0	-	-	V
V _{IL}	LOW-level input voltage		-	-	0.8	V
I _{OH}	HIGH-level output current		-32	-	-	mA
I _{OL}	LOW-level output current	none	-	-	32	mA
		current duty cycle ≤ 50 %; f _i ≥ 1 kHz	-	-	64	mA
T _{amb}	ambient temperature	in free-air	-40	-	+85	°C
Δt/ΔV	input transition rise and fall rate	outputs enabled	-	-	10	ns/V

9. Static characteristics

Table 6. Static characteristics

At recommended operating conditions; voltages are referenced to GND (ground = 0 V).

Symbol	Parameter	Conditions	Min	Typ ^[1]	Max	Unit	
T_{amb} = -40 °C to +85 °C							
V _{IK}	input clamping voltage	V _{CC} = 2.7 V; I _{IK} = -18 mA	-1.2	-0.85	-	V	
V _{OH}	HIGH-level output voltage	I _{OH} = -100 μA; V _{CC} = 2.7 V to 3.6 V	V _{CC} - 0.2	V _{CC}	-	V	
		I _{OH} = -8 mA; V _{CC} = 2.7 V	2.4	2.5	-	V	
		I _{OH} = -32 mA; V _{CC} = 3.0 V	2.0	2.3	-	V	
V _{OL}	LOW-level output voltage	V _{CC} = 2.7 V					
		I _{OL} = 100 μA	-	0.07	0.2	V	
		I _{OL} = 24 mA	-	0.3	0.5	V	
		V _{CC} = 3.0 V					
		I _{OL} = 16 mA	-	0.25	0.4	V	
		I _{OL} = 32 mA	-	0.3	0.5	V	
V _{OL(pu)}	power-up LOW-level output voltage	I _{OL} = 64 mA	-	0.4	0.55	V	
		V _{CC} = 3.6 V; I _O = 1 mA; V _I = V _{CC} or GND	[2]	-	0.1	0.55	V
I _I	input leakage current	control pins					
		V _{CC} = 3.6 V; V _I = V _{CC} or GND	-	0.1	±1	μA	
		V _{CC} = 0 V or 3.6 V; V _I = 5.5 V	-	0.4	10	μA	
		input data pins	[3]				
		V _{CC} = 0 V or 3.6 V; V _I = 5.5 V	-	0.4	10	μA	
		V _{CC} = 3.6 V; V _I = V _{CC}	-	0.1	1	μA	
I _{OFF}	power-off leakage current	V _{CC} = 3.6 V; V _I = 0 V	-5	-0.4	-	μA	
		V _{CC} = 0 V; V _I or V _O = 0 V to 4.5 V	-	0.1	±100	μA	
I _{BHL}	bus hold LOW current	V _{CC} = 3 V; V _I = 0.8 V	75	135	-	μA	
I _{BHH}	bus hold HIGH current	V _{CC} = 3 V; V _I = 2.0 V	-	-135	-75	μA	
I _{BHLO}	bus hold LOW overdrive current	input data pins;	[4]	500	-	μA	
		V _I = 0 V to 3.6 V; V _{CC} = 3.6 V					
I _{BHHO}	bus hold HIGH overdrive current	input data pins;	[4]	-	-	-500	μA
		V _I = 0 V to 3.6 V; V _{CC} = 3.6 V					
I _{LO}	output leakage current	output in HIGH-state when V _O > V _{CC} ; V _O = 5.5 V; V _{CC} = 3.0 V	-	50	125	μA	
I _{O(pu/pd)}	power-up/power-down output current	V _{CC} ≤ 1.2 V; V _O = 0.5 V to V _{CC} ; V _I = GND or V _{CC} ; nOE = don't care	[5]	-	1	±100	μA
I _{OZ}	OFF-state output current	V _{CC} = 3.6 V; V _I = V _{IH} or V _{IL}					
		output HIGH: V _O = 3.0 V	-	0.5	5	μA	
		output LOW: V _O = 0.5 V	-5	0.5	-	μA	
I _{CC}	supply current	V _{CC} = 3.6 V; V _I = GND or V _{CC} ; I _O = 0 A					
		outputs HIGH	-	0.07	0.12	mA	
		outputs LOW	-	4.0	6.0	mA	
		outputs disabled	[6]	-	0.07	0.12	mA

Table 6. Static characteristics ...continued

At recommended operating conditions; voltages are referenced to GND (ground = 0 V).

Symbol	Parameter	Conditions	Min	Typ ^[1]	Max	Unit
ΔI_{CC}	additional supply current	per input pin; $V_{CC} = 3.0$ V to 3.6 V; one input at $V_{CC} - 0.6$ V, other inputs at V_{CC} or GND	[7] -	0.1	0.2	mA
C_I	input capacitance	input pins; $V_I = 0$ V or 3.0 V	-	3	-	pF
C_O	output capacitance	output pins nQn; outputs disabled; $V_O = 0$ V or V_{CC}	-	9	-	pF

[1] Typical values are measured at $V_{CC} = 3.3$ V and at $T_{amb} = 25$ °C.

[2] For valid test results, data must not be loaded into the flips-flops (or latches) after applying power.

[3] Unused pins at V_{CC} or GND.

[4] This is the bus hold overdrive current required to force the input to the opposite logic state.

[5] This parameter is valid for any V_{CC} between 0 V and 1.2 V with a transition time of up to 10 ms. From $V_{CC} = 1.2$ V to $V_{CC} = 3.3$ V \pm 0.3 V a transition time of 100 μ s is permitted. This parameter is valid for $T_{amb} = 25$ °C only.[6] I_{CC} is measured with outputs pulled to V_{CC} or GND.[7] This is the increase in supply current for each input at the specified voltage level other than V_{CC} or GND.

10. Dynamic characteristics

Table 7. Dynamic characteristicsVoltages are referenced to GND (ground = 0 V); for test circuit see [Figure 10](#).

Symbol	Parameter	Conditions	Min	Typ ^[1]	Max	Unit
$T_{amb} = -40$ °C to $+85$ °C						
f_{max}	maximum frequency	nCP; $V_{CC} = 3.3$ V \pm 0.3 V; see Figure 7	150	-	-	MHz
t_{PLH}	LOW to HIGH propagation delay	nCP to nQn; see Figure 7				
		$V_{CC} = 3.3$ V \pm 0.3 V	1.5	2.9	5.0	ns
		$V_{CC} = 2.7$ V	-	-	5.6	ns
t_{PHL}	HIGH to LOW propagation delay	nCP to nQn; see Figure 7				
		$V_{CC} = 3.3$ V \pm 0.3 V	1.5	3.0	5.0	ns
		$V_{CC} = 2.7$ V	-	-	5.6	ns
t_{PZH}	OFF-state to HIGH propagation delay	\overline{nOE} to nQn; see Figure 8				
		$V_{CC} = 3.3$ V \pm 0.3 V	1.5	3.2	4.8	ns
		$V_{CC} = 2.7$ V	-	-	6.0	ns
t_{PZL}	OFF-state to LOW propagation delay	\overline{nOE} to nQn; see Figure 8				
		$V_{CC} = 3.3$ V \pm 0.3 V	1.5	3.0	4.6	ns
		$V_{CC} = 2.7$ V	-	-	5.2	ns
t_{PHZ}	HIGH to OFF-state propagation delay	\overline{nOE} to nQn; see Figure 8				
		$V_{CC} = 3.3$ V \pm 0.3 V	1.5	3.9	5.4	ns
		$V_{CC} = 2.7$ V	-	-	6.0	ns
t_{PLZ}	LOW to OFF-state propagation delay	\overline{nOE} to nQn; see Figure 8				
		$V_{CC} = 3.3$ V \pm 0.3 V	1.5	3.4	4.6	ns
		$V_{CC} = 2.7$ V	-	-	5.0	ns

Table 7. Dynamic characteristics ...continued

Voltages are referenced to GND (ground = 0 V); for test circuit see [Figure 10](#).

Symbol	Parameter	Conditions	Min	Typ ^[1]	Max	Unit
t _{su}	set-up time	nDn to nCP; HIGH or LOW; see Figure 9	[2]			
		V _{CC} = 3.3 V ± 0.3 V	2.0	0.7	-	ns
		V _{CC} = 2.7 V	2.0	-	-	ns
t _h	hold time	nDn to nCP; HIGH or LOW; see Figure 9	[3]			
		V _{CC} = 3.3 V ± 0.3 V	0.8	0	-	ns
		V _{CC} = 2.7 V	0.1	-	-	ns
t _w	pulse width	nCP HIGH; see Figure 7	[4]			
		V _{CC} = 3.3 V ± 0.3 V	1.5	0.6	-	ns
		V _{CC} = 2.7 V	1.5	-	-	ns
		nCP LOW; see Figure 7				
		V _{CC} = 3.3 V ± 0.3 V	3.0	1.6	-	ns
		V _{CC} = 2.7 V	3.0	-	-	ns

[1] All typical values are at V_{CC} = 3.3 V and T_{amb} = 25 °C.

[2] t_{su} is the same as t_{su(H)} and t_{su(L)}.

[3] t_h is the same as t_{h(H)} and t_{h(L)}.

[4] t_w is the same as t_{w(H)} and t_{w(L)}.

11. Waveforms

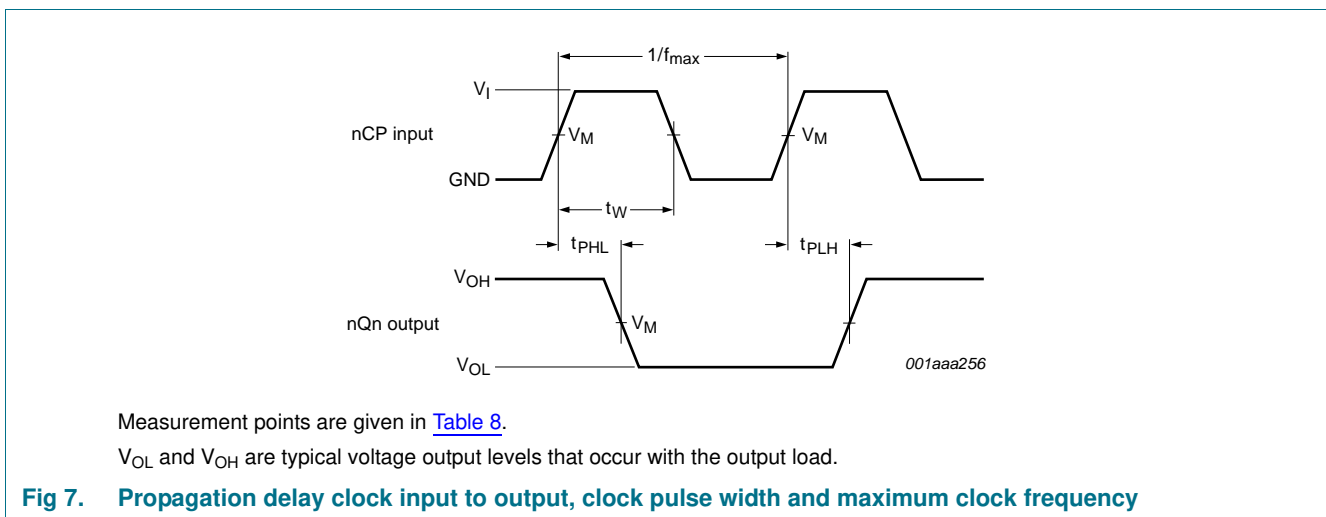
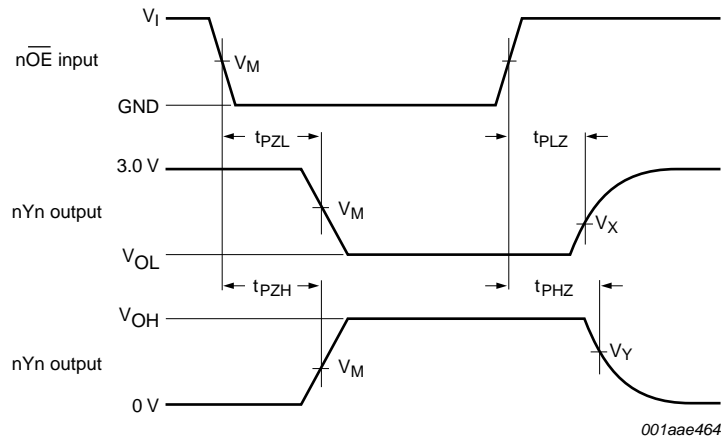

Table 8. Measurement points

Input	Output		
V _M	V _M	V _X	V _Y
1.5 V	1.5 V	V _{OL} + 0.3 V	V _{OH} - 0.3 V



Measurements points are given in [Table 8](#).

V_{OL} and V_{OH} are typical voltage output levels that occur with the output load.

Fig 8. Enable and disable times

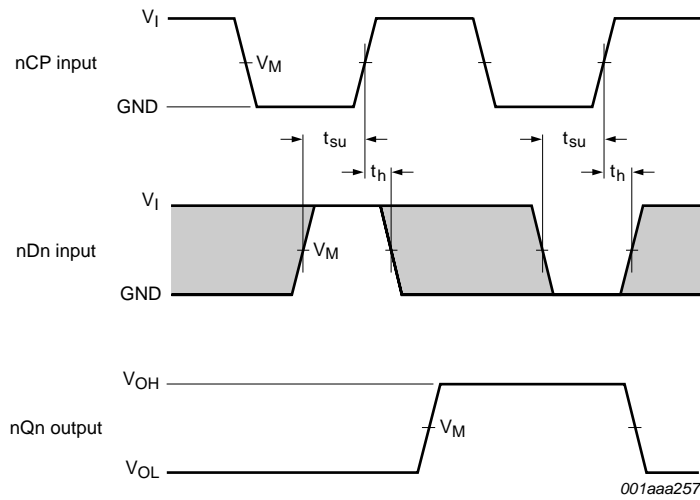

Measurement points are given in [Table 8](#).

V_{OL} and V_{OH} are typical voltage output levels that occur with the output load.

Remark: The shaded areas indicate when the input is permitted to change for predictable output performance.

Fig 9. Data set-up and hold times

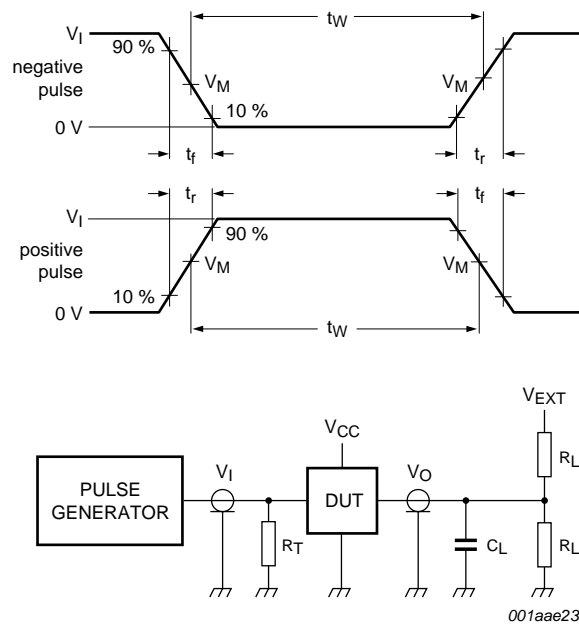

Test data is given in [Table 9](#).

Definitions test circuit:

R_L = Load resistance.

C_L = Load capacitance including jig and probe capacitance.

R_T = Termination resistance should be equal to output impedance Z_o of the pulse generator.

V_{EXT} = Test voltage for switching times.

Fig 10. Test circuit for measuring switching times

Table 9. Test data

Input				Load		V_{EXT}		
V_I	f_i	t_w	t_r, t_f	C_L	R_L	t_{PHZ}, t_{PZH}	t_{PLZ}, t_{PZL}	t_{PLH}, t_{PHL}
2.7 V	≤ 10 MHz	500 ns	≤ 2.5 ns	50 pF	500 Ω	GND	6 V	open

12. Package outline

SSOP48: plastic shrink small outline package; 48 leads; body width 7.5 mm

SOT370-1

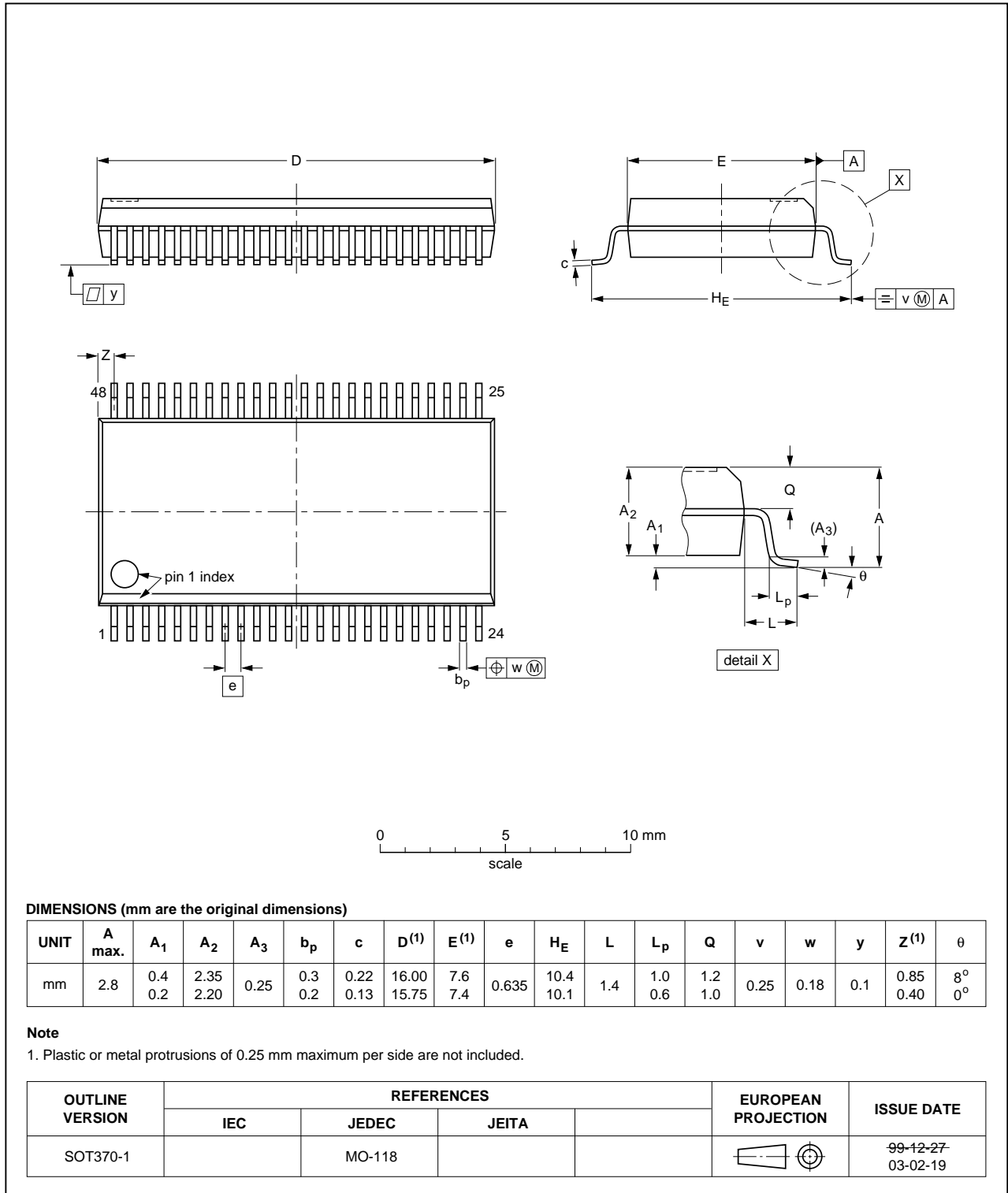

Fig 11. Package outline SOT370-1 (SSOP48)

TSSOP48: plastic thin shrink small outline package; 48 leads; body width 6.1 mm

SOT362-1

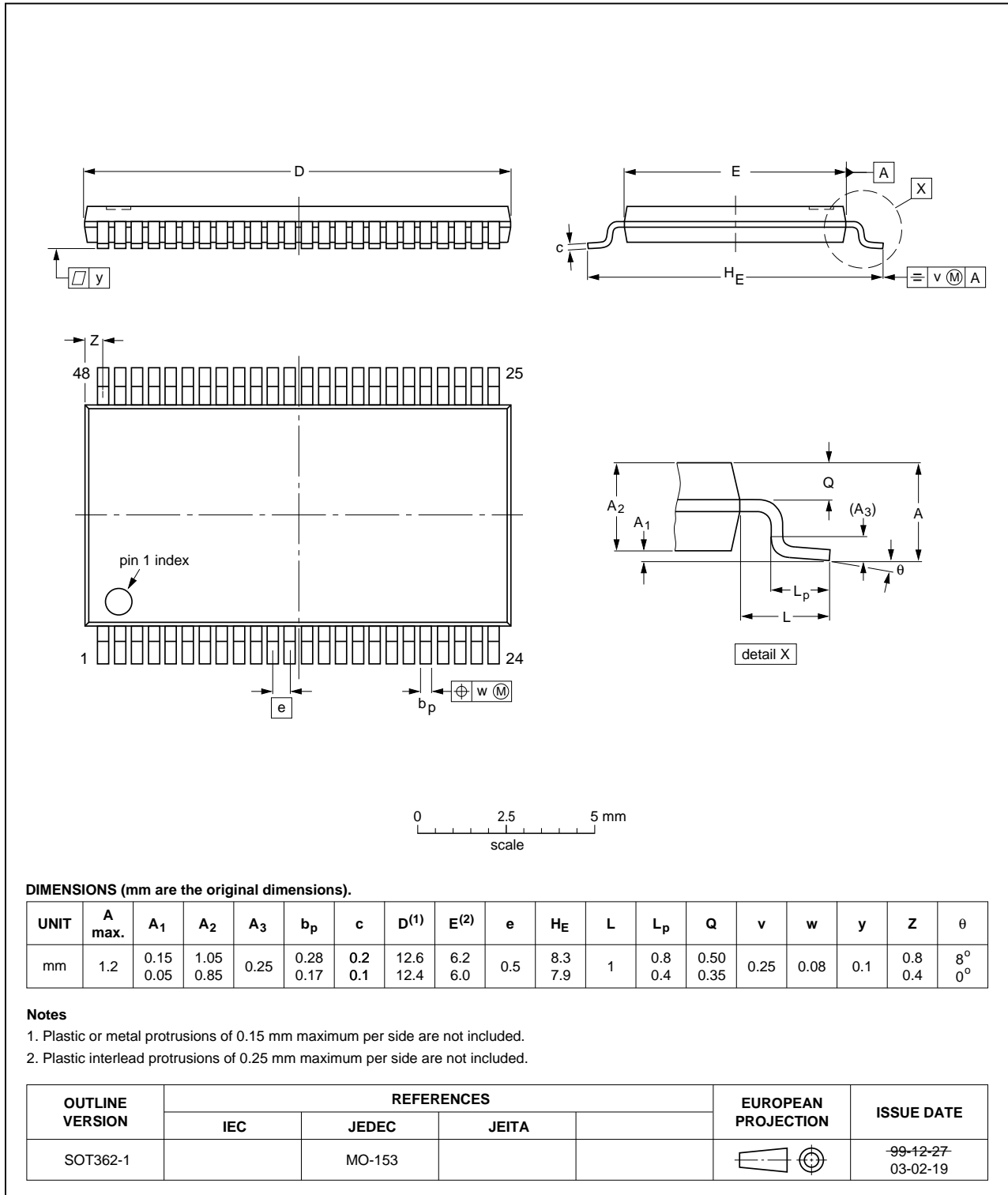

Fig 12. Package outline SOT362-1 (TSSOP48)

VFBGA56: plastic very thin fine-pitch ball grid array package; 56 balls; body 4.5 x 7 x 0.65 mm

SOT702-1

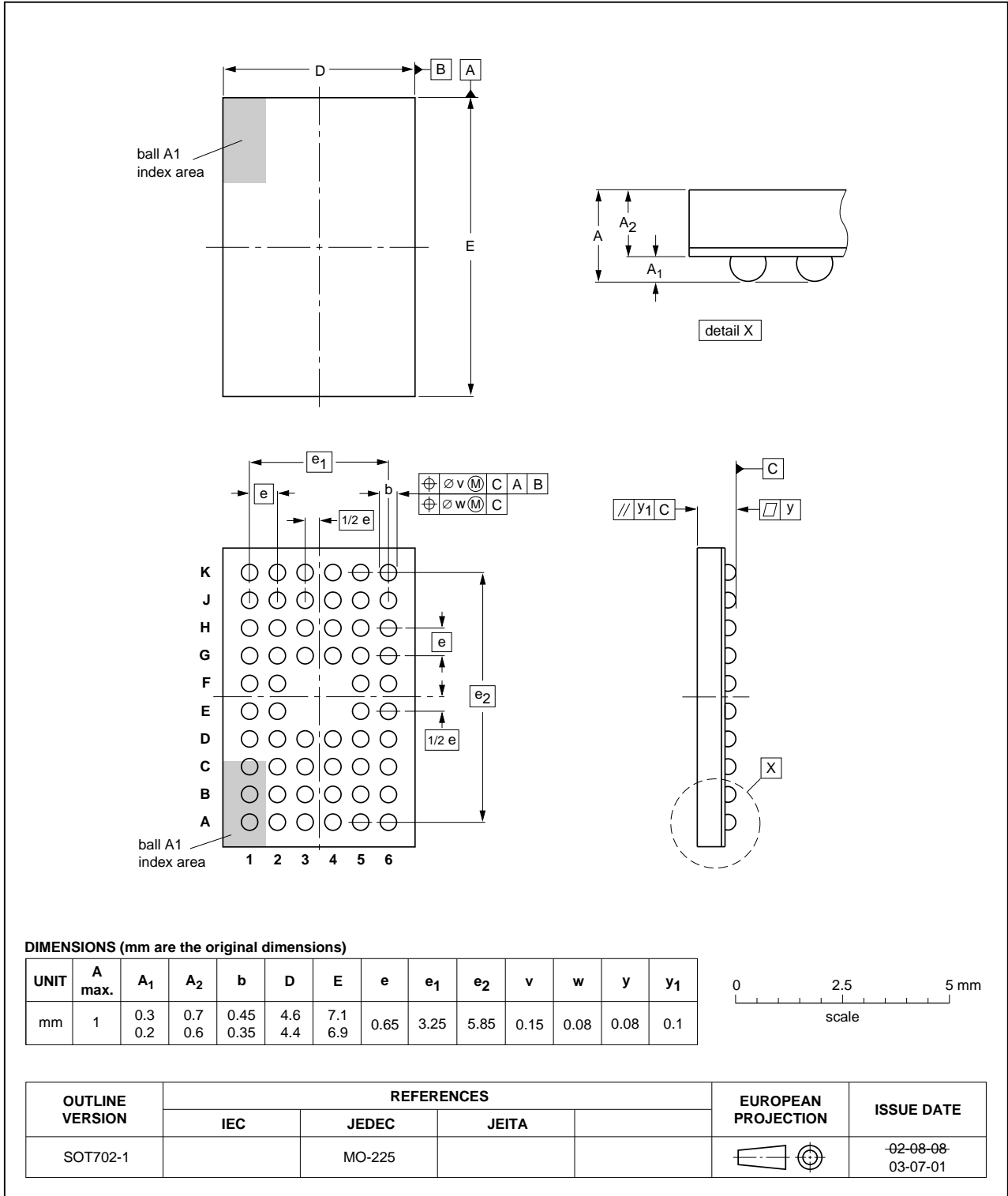

Fig 13. Package outline SOT702-1 (VFBGA56)

HXQFN60: plastic compatible thermal enhanced extremely thin quad flat package; no leads; 60 terminals; body 4 x 6 x 0.5 mm

SOT1134-2

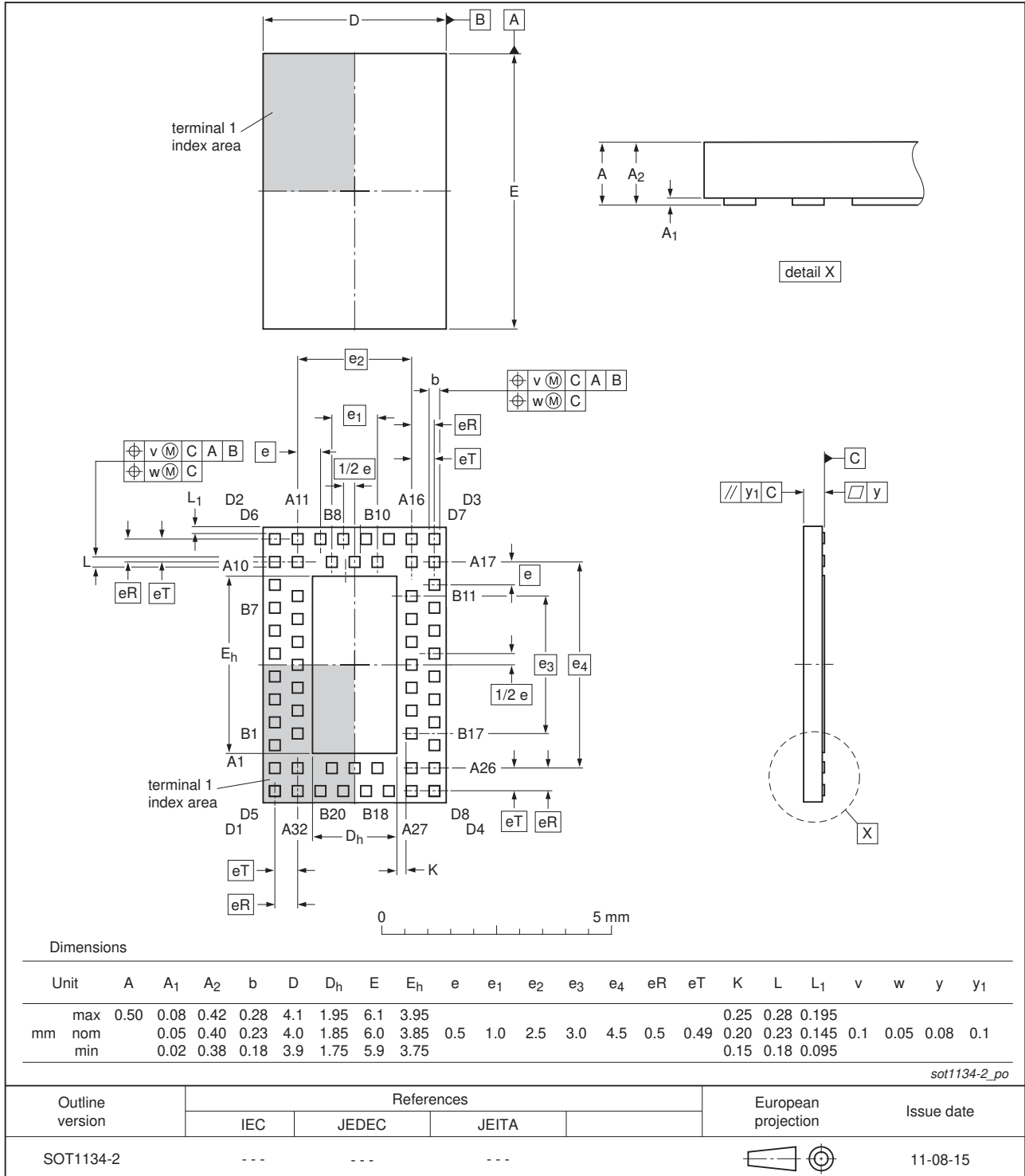

Fig 14. Package outline SOT1134-2 (HXQFN60)

13. Abbreviations

Table 10. Abbreviations

Acronym	Description
BiCMOS	Bipolar Complementary Metal Oxide Semiconductor
DUT	Device Under Test
ESD	ElectroStatic Discharge
HBM	Human Body Model
MM	Machine Model
TTL	Transistor-Transistor Logic

14. Revision history

Table 11. Revision history

Document ID	Release date	Data sheet status	Change notice	Supersedes
74LVT_LVTH16374A v.10	20120402	Product data sheet	-	74LVT_LVTH16374A v.9
Modifications:	<ul style="list-style-type: none"> For type number 74LVTH16374ABX the sot code has changed to SOT1134-2. 			
74LVT_LVTH16374A v.9	20111122	Product data sheet	-	74LVT_LVTH16374A v.8
Modifications:	<ul style="list-style-type: none"> Legal pages updated. 			
74LVT_LVTH16374A v.8	20110620	Product data sheet	-	74LVT_LVTH16374A v.7
74LVT_LVTH16374A v.7	20100322	Product data sheet	-	74LVT_LVTH16374A v.6
74LVT_LVTH16374A v.6	20100118	product data sheet	-	74LVT16374A v.5
74LVT16374A v.5	20040916	product data sheet	-	74LVT16374A v.4
74LVT16374A v.4	20021101	product specification	-	74LVT16374A v.3
74LVT16374A v.3	19991018	product specification	-	74LVT16374A v.2
74LVT16374A v.2	19980219	product specification	-	-

15. Legal information

15.1 Data sheet status

Document status ^{[1][2]}	Product status ^[3]	Definition
Objective [short] data sheet	Development	This document contains data from the objective specification for product development.
Preliminary [short] data sheet	Qualification	This document contains data from the preliminary specification.
Product [short] data sheet	Production	This document contains the product specification.

[1] Please consult the most recently issued document before initiating or completing a design.

[2] The term 'short data sheet' is explained in section "Definitions".

[3] The product status of device(s) described in this document may have changed since this document was published and may differ in case of multiple devices. The latest product status information is available on the Internet at URL <http://www.nxp.com>.

15.2 Definitions

Draft — The document is a draft version only. The content is still under internal review and subject to formal approval, which may result in modifications or additions. NXP Semiconductors does not give any representations or warranties as to the accuracy or completeness of information included herein and shall have no liability for the consequences of use of such information.

Short data sheet — A short data sheet is an extract from a full data sheet with the same product type number(s) and title. A short data sheet is intended for quick reference only and should not be relied upon to contain detailed and full information. For detailed and full information see the relevant full data sheet, which is available on request via the local NXP Semiconductors sales office. In case of any inconsistency or conflict with the short data sheet, the full data sheet shall prevail.

Product specification — The information and data provided in a Product data sheet shall define the specification of the product as agreed between NXP Semiconductors and its customer, unless NXP Semiconductors and customer have explicitly agreed otherwise in writing. In no event however, shall an agreement be valid in which the NXP Semiconductors product is deemed to offer functions and qualities beyond those described in the Product data sheet.

15.3 Disclaimers

Limited warranty and liability — Information in this document is believed to be accurate and reliable. However, NXP Semiconductors does not give any representations or warranties, expressed or implied, as to the accuracy or completeness of such information and shall have no liability for the consequences of use of such information. NXP Semiconductors takes no responsibility for the content in this document if provided by an information source outside of NXP Semiconductors.

In no event shall NXP Semiconductors be liable for any indirect, incidental, punitive, special or consequential damages (including - without limitation - lost profits, lost savings, business interruption, costs related to the removal or replacement of any products or rework charges) whether or not such damages are based on tort (including negligence), warranty, breach of contract or any other legal theory.

Notwithstanding any damages that customer might incur for any reason whatsoever, NXP Semiconductors' aggregate and cumulative liability towards customer for the products described herein shall be limited in accordance with the *Terms and conditions of commercial sale* of NXP Semiconductors.

Right to make changes — NXP Semiconductors reserves the right to make changes to information published in this document, including without limitation specifications and product descriptions, at any time and without notice. This document supersedes and replaces all information supplied prior to the publication hereof.

Suitability for use — NXP Semiconductors products are not designed, authorized or warranted to be suitable for use in life support, life-critical or safety-critical systems or equipment, nor in applications where failure or malfunction of an NXP Semiconductors product can reasonably be expected to result in personal injury, death or severe property or environmental damage. NXP Semiconductors and its suppliers accept no liability for inclusion and/or use of NXP Semiconductors products in such equipment or applications and therefore such inclusion and/or use is at the customer's own risk.

Applications — Applications that are described herein for any of these products are for illustrative purposes only. NXP Semiconductors makes no representation or warranty that such applications will be suitable for the specified use without further testing or modification.

Customers are responsible for the design and operation of their applications and products using NXP Semiconductors products, and NXP Semiconductors accepts no liability for any assistance with applications or customer product design. It is customer's sole responsibility to determine whether the NXP Semiconductors product is suitable and fit for the customer's applications and products planned, as well as for the planned application and use of customer's third party customer(s). Customers should provide appropriate design and operating safeguards to minimize the risks associated with their applications and products.

NXP Semiconductors does not accept any liability related to any default, damage, costs or problem which is based on any weakness or default in the customer's applications or products, or the application or use by customer's third party customer(s). Customer is responsible for doing all necessary testing for the customer's applications and products using NXP Semiconductors products in order to avoid a default of the applications and the products or of the application or use by customer's third party customer(s). NXP does not accept any liability in this respect.

Limiting values — Stress above one or more limiting values (as defined in the Absolute Maximum Ratings System of IEC 60134) will cause permanent damage to the device. Limiting values are stress ratings only and (proper) operation of the device at these or any other conditions above those given in the Recommended operating conditions section (if present) or the Characteristics sections of this document is not warranted. Constant or repeated exposure to limiting values will permanently and irreversibly affect the quality and reliability of the device.

Terms and conditions of commercial sale — NXP Semiconductors products are sold subject to the general terms and conditions of commercial sale, as published at <http://www.nxp.com/profile/terms>, unless otherwise agreed in a valid written individual agreement. In case an individual agreement is concluded only the terms and conditions of the respective agreement shall apply. NXP Semiconductors hereby expressly objects to applying the customer's general terms and conditions with regard to the purchase of NXP Semiconductors products by customer.

No offer to sell or license — Nothing in this document may be interpreted or construed as an offer to sell products that is open for acceptance or the grant, conveyance or implication of any license under any copyrights, patents or other industrial or intellectual property rights.

Export control — This document as well as the item(s) described herein may be subject to export control regulations. Export might require a prior authorization from competent authorities.

Non-automotive qualified products — Unless this data sheet expressly states that this specific NXP Semiconductors product is automotive qualified, the product is not suitable for automotive use. It is neither qualified nor tested in accordance with automotive testing or application requirements. NXP Semiconductors accepts no liability for inclusion and/or use of non-automotive qualified products in automotive equipment or applications.

In the event that customer uses the product for design-in and use in automotive applications to automotive specifications and standards, customer (a) shall use the product without NXP Semiconductors' warranty of the product for such automotive applications, use and specifications, and (b) whenever customer uses the product for automotive applications beyond

NXP Semiconductors' specifications such use shall be solely at customer's own risk, and (c) customer fully indemnifies NXP Semiconductors for any liability, damages or failed product claims resulting from customer design and use of the product for automotive applications beyond NXP Semiconductors' standard warranty and NXP Semiconductors' product specifications.

Translations — A non-English (translated) version of a document is for reference only. The English version shall prevail in case of any discrepancy between the translated and English versions.

15.4 Trademarks

Notice: All referenced brands, product names, service names and trademarks are the property of their respective owners.

16. Contact information

For more information, please visit: <http://www.nxp.com>

For sales office addresses, please send an email to: salesaddresses@nxp.com

17. Contents

1	General description	1
2	Features and benefits	1
3	Ordering information	2
4	Functional diagram	2
5	Pinning information	3
5.1	Pinning	3
5.2	Pin description	5
6	Functional description	5
7	Limiting values	6
8	Recommended operating conditions	6
9	Static characteristics	7
10	Dynamic characteristics	8
11	Waveforms	9
12	Package outline	12
13	Abbreviations	16
14	Revision history	16
15	Legal information	17
15.1	Data sheet status	17
15.2	Definitions	17
15.3	Disclaimers	17
15.4	Trademarks	18
16	Contact information	18
17	Contents	19

Please be aware that important notices concerning this document and the product(s) described herein, have been included in section 'Legal information'.

© NXP B.V. 2012.

All rights reserved.

For more information, please visit: <http://www.nxp.com>

For sales office addresses, please send an email to: salesaddresses@nxp.com

Date of release: 2 April 2012

Document identifier: 74LVT_LVTH16374A