

**SAW Filter 869.0MHz**

**Model: TA1404A**

**Part No: MP09815 (AEC-Q200 Compliant)**

**Rev No: 4**

**A. MAXIMUM RATING:**

Electrostatic Sensitive Device (ESD)

1. Maximum Pulse Input Power 27dBm  
 Maximum Input Power Handling (at 50°C during 50 000 hours) 20dBm
2. DC Voltage: 6V
3. Operating Temperature: -40°C to +85°C
4. Storage Temperature: -40°C to +85°C
5. Moisture Sensitivity Level: Level 1 (MSL1)

**B. ELECTRICAL CHARACTERISTICS:**

1. Terminating source impedance (single):  $Z_S = 50\Omega$
2. Terminating load impedance (single):  $Z_L = 50\Omega$

Item	Unit	Min	Typ.	Max
Center Frequency Fc	MHz	-	869	-
Insertion Loss (868~870MHz) IL	dB		2.3	3.0max
Amplitude ripple(868~870 MHz)	dB		0.3	0.6max
Attenuation				
100 ~ 300MHz	dB	45	50	
300 ~ 845MHz	dB	40	45	
845 ~ 853MHz	dB	38	43	
879 ~ 883MHz	dB	15	30	
883 ~ 915MHz	dB	40	45	
915 ~ 945MHz	dB	45	50	
945 ~ 1200MHz	dB	45	55	
1200 ~ 2000MHz	dB	35	40	
Package size	mm	SMD 3x3		

**C. TEST CIRCUIT:**

Network analyzer

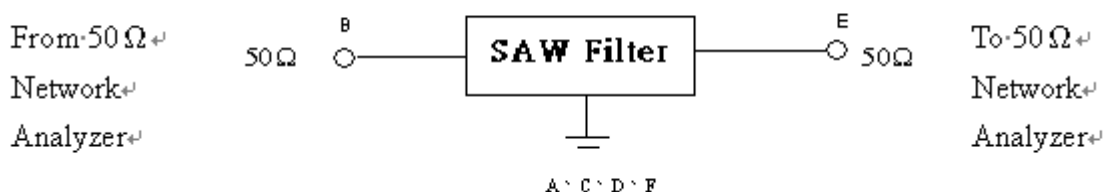

**SAW Filter 869.0MHz**  
**Part No: MP09815 (AEC-Q200 Compliant)**

**Model: TA1404A**  
**Rev No: 4**

**D. FREQUENCY CHARACTERISTICS:**

1. S21 response: (Span 200MHz)

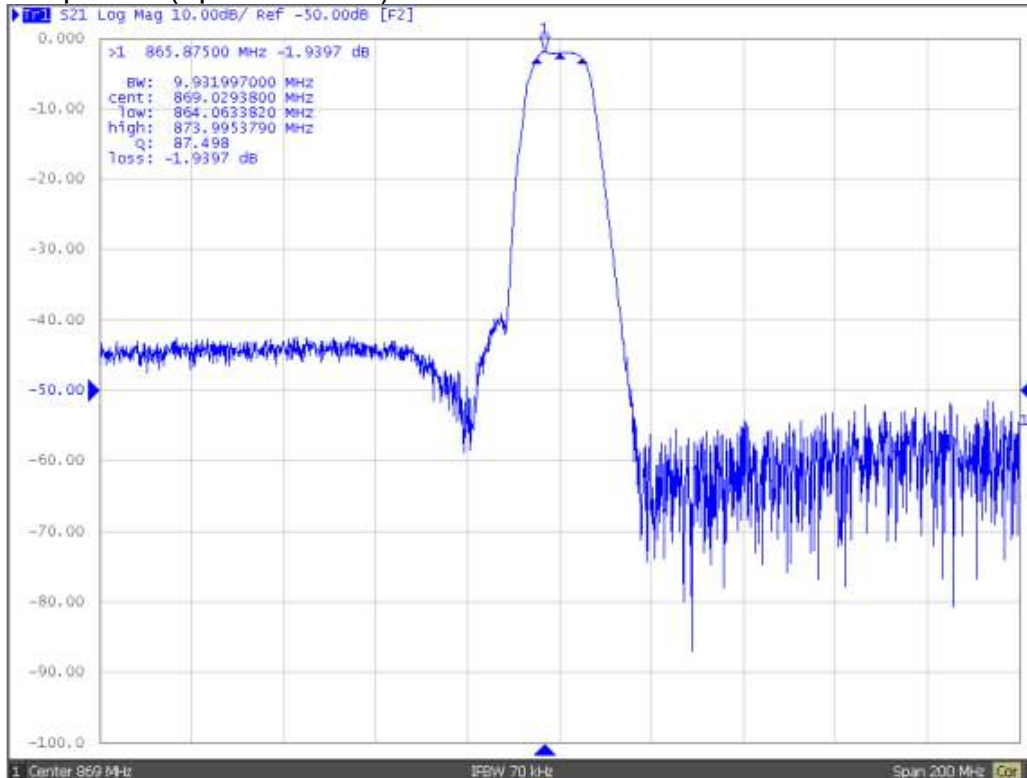

2. S21 response: (Span 20MHz)

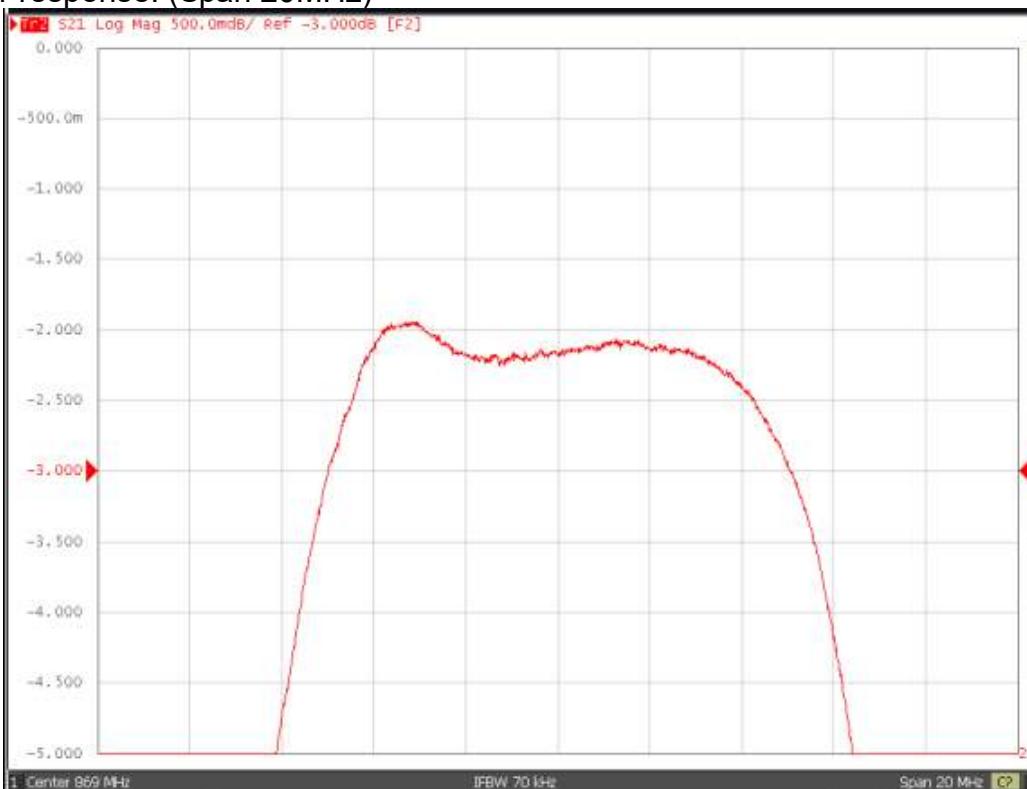

**SAW Filter 869.0MHz**  
**Part No: MP09815 (AEC-Q200 Compliant)**

**Model: TA1404A**  
**Rev No: 4**

3. S21 response: (100kHz ~ 3GHz)

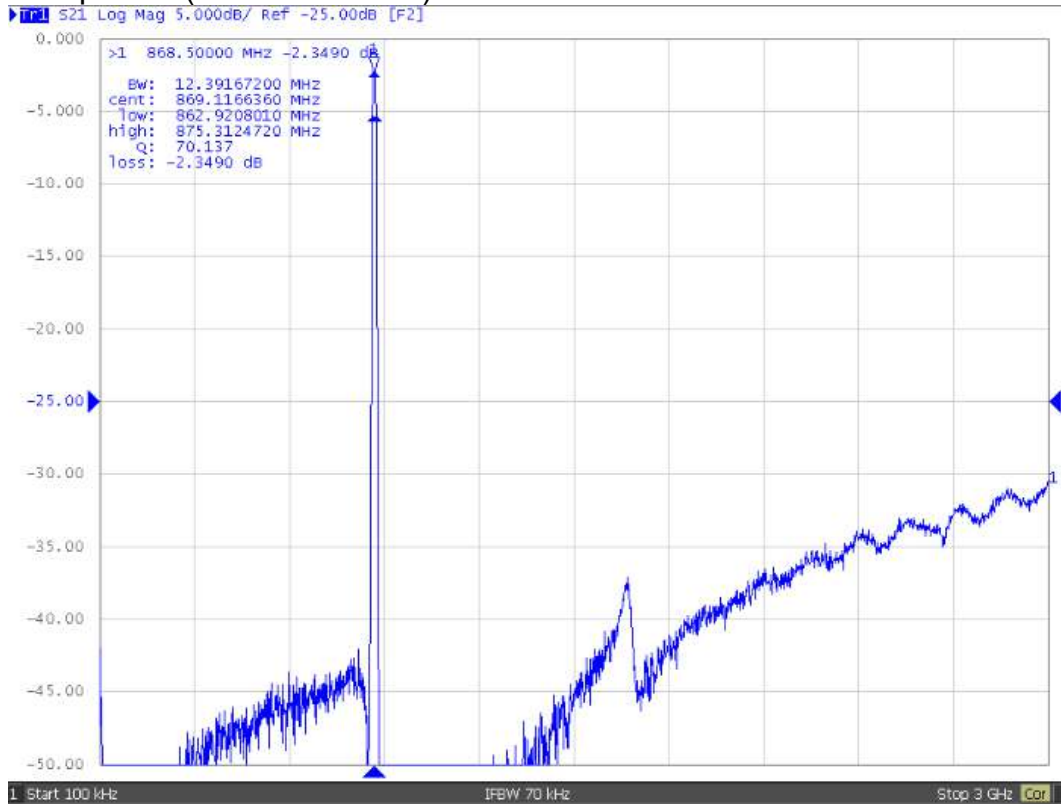

4. S11 response:

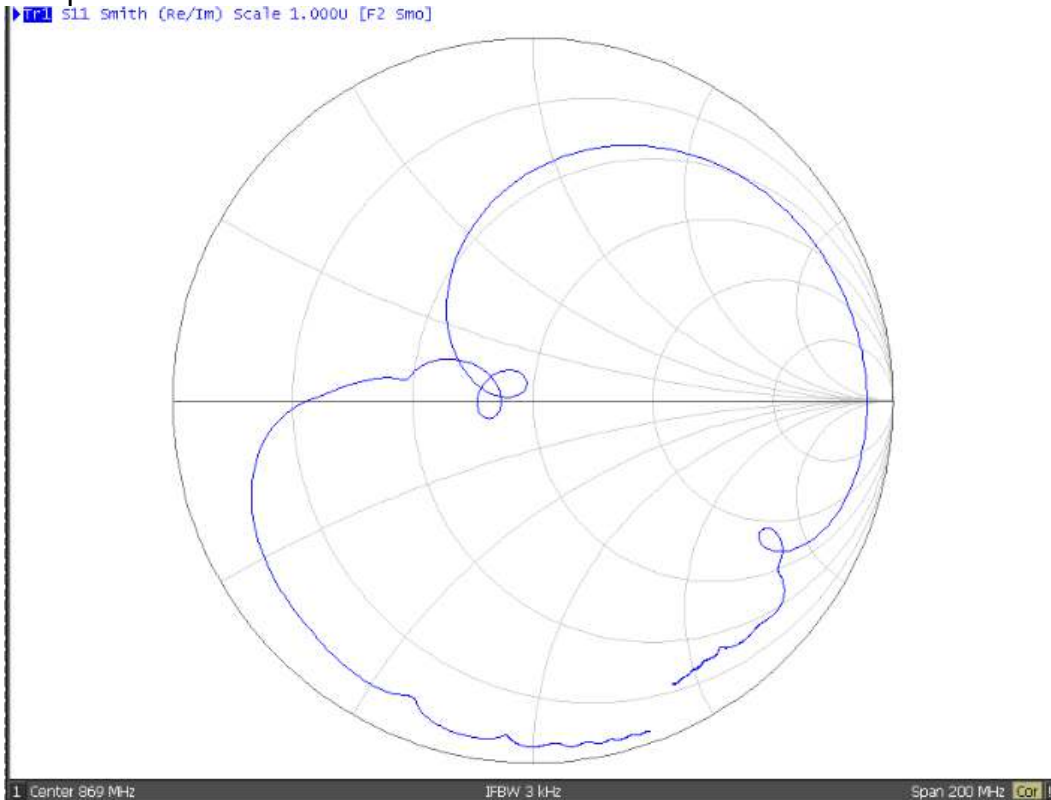

**SAW Filter 869.0MHz**  
**Part No: MP09815 (AEC-Q200 Compliant)**

**Model: TA1404A**  
**Rev No: 4**

5. S22 response:

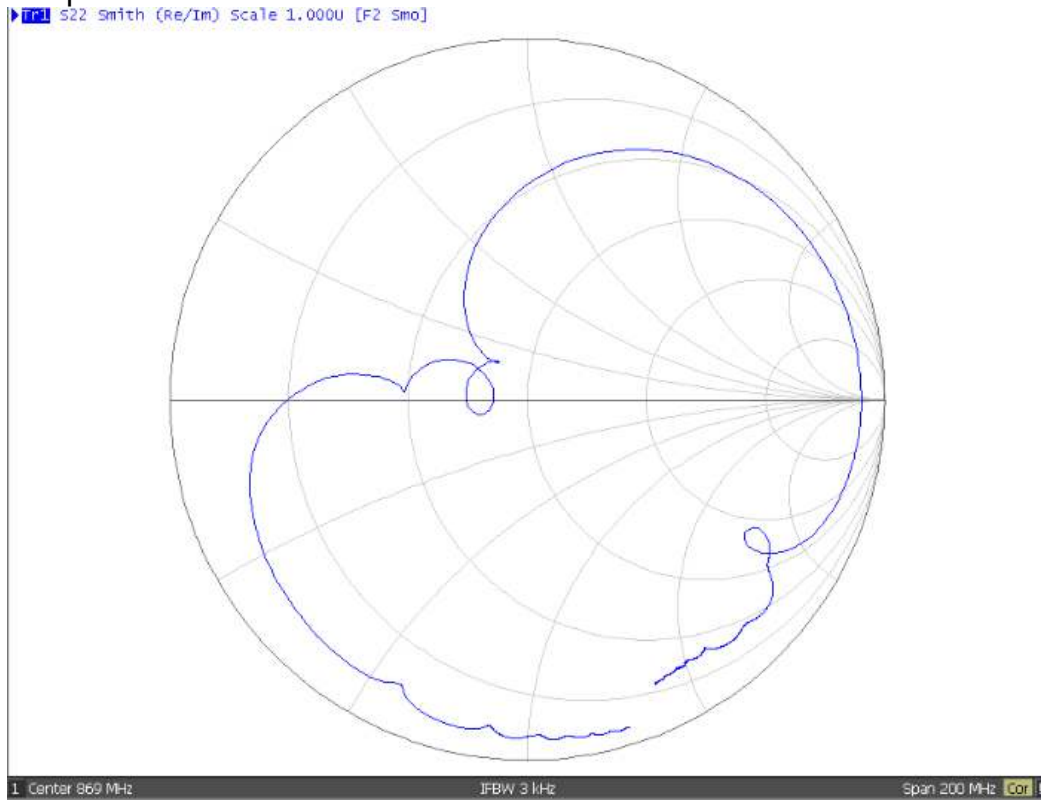

**SAW Filter 869.0MHz**

**Model: TA1404A**

**Part No: MP09815 (AEC-Q200 Compliant)**

**Rev No: 4**

**E. PCB FOOTPRINT:**

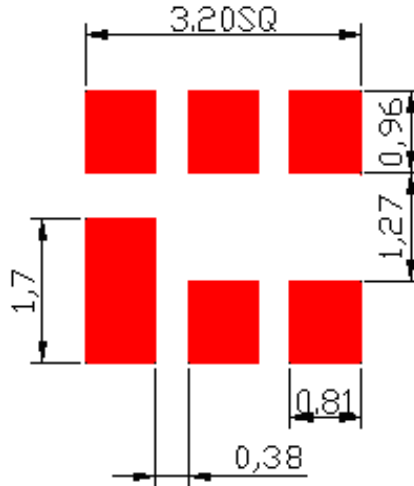

**F. OUTLINE DRAWING:**

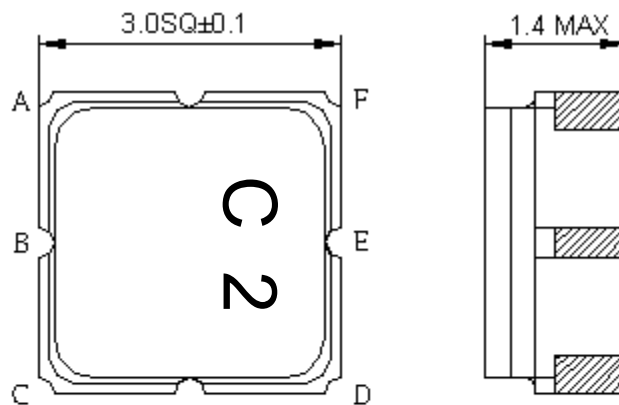

Not Specified Tolerance : +/-0.15 mm  
 Unit: mm

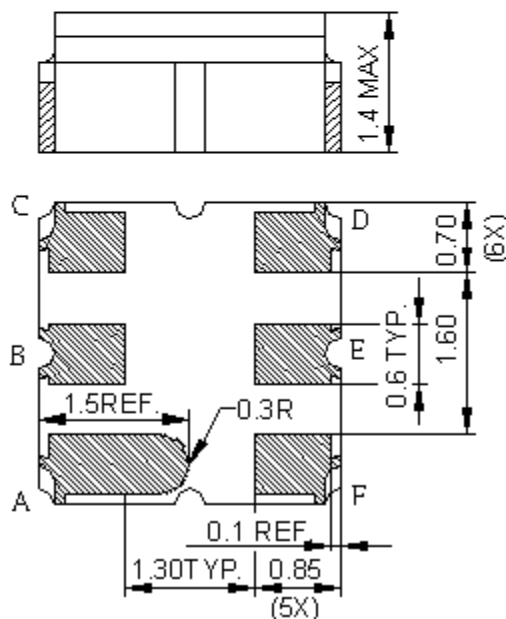

B: Input  
 E: Output  
 A, C, D, F: Ground  
 Unit: mm

**SAW Filter 869.0MHz**  
**Part No: MP09815 (AEC-Q200 Compliant)**

**Model: TA1404A**  
**Rev No: 4**

**G. PACKING:**

1. Reel Dimensions:

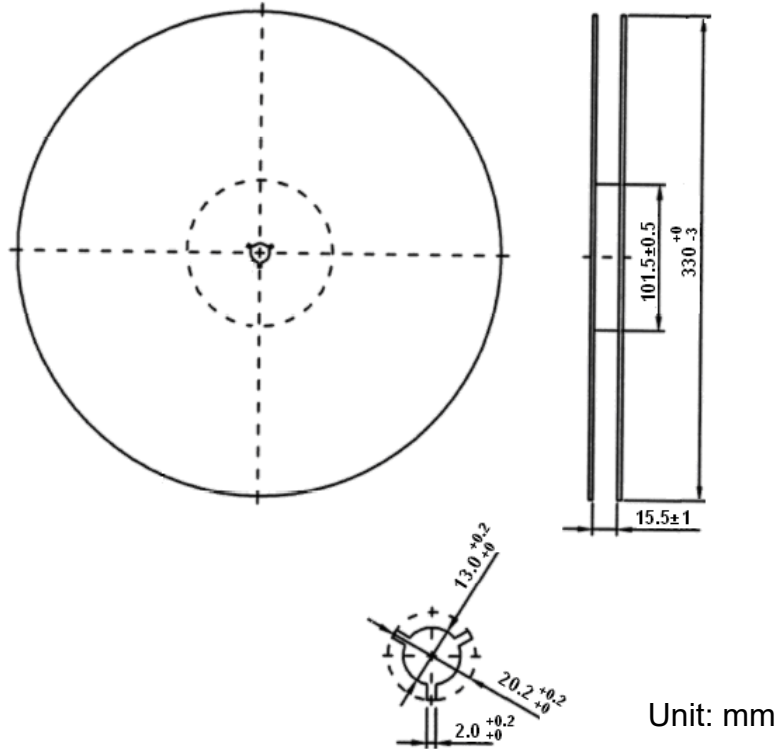

2. Tape Dimensions:

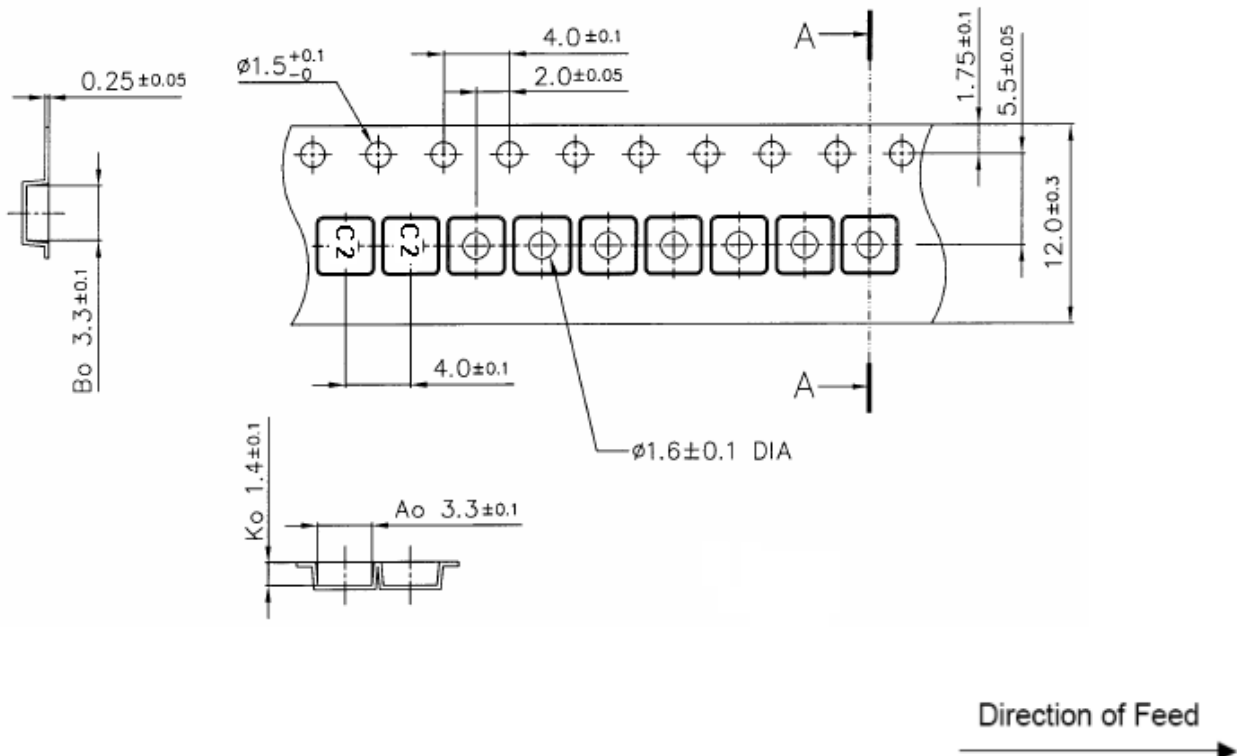

**SAW Filter 869.0MHz**  
**Part No: MP09815 (AEC-Q200 Compliant)**

**Model: TA1404A**  
**Rev No: 4**

**H. RECOMMENDED REFLOW PROFILE:**

1. Preheating shall be fixed at 150~180°C for 60~90 seconds.
2. Ascending time to preheating temperature 150°C shall be 30 seconds min.
3. Heating shall be fixed at 220°C for 50~80 seconds and at 260°C +0/-5°C peak (20 ~ 40sec).
4. Time: 2 times.

