

REVISIONS				
REV	DATE	BY	APP'D	DESCRIPTION
AG	27JAN2023	RK	JO	REVISED PER ECN-23-195747

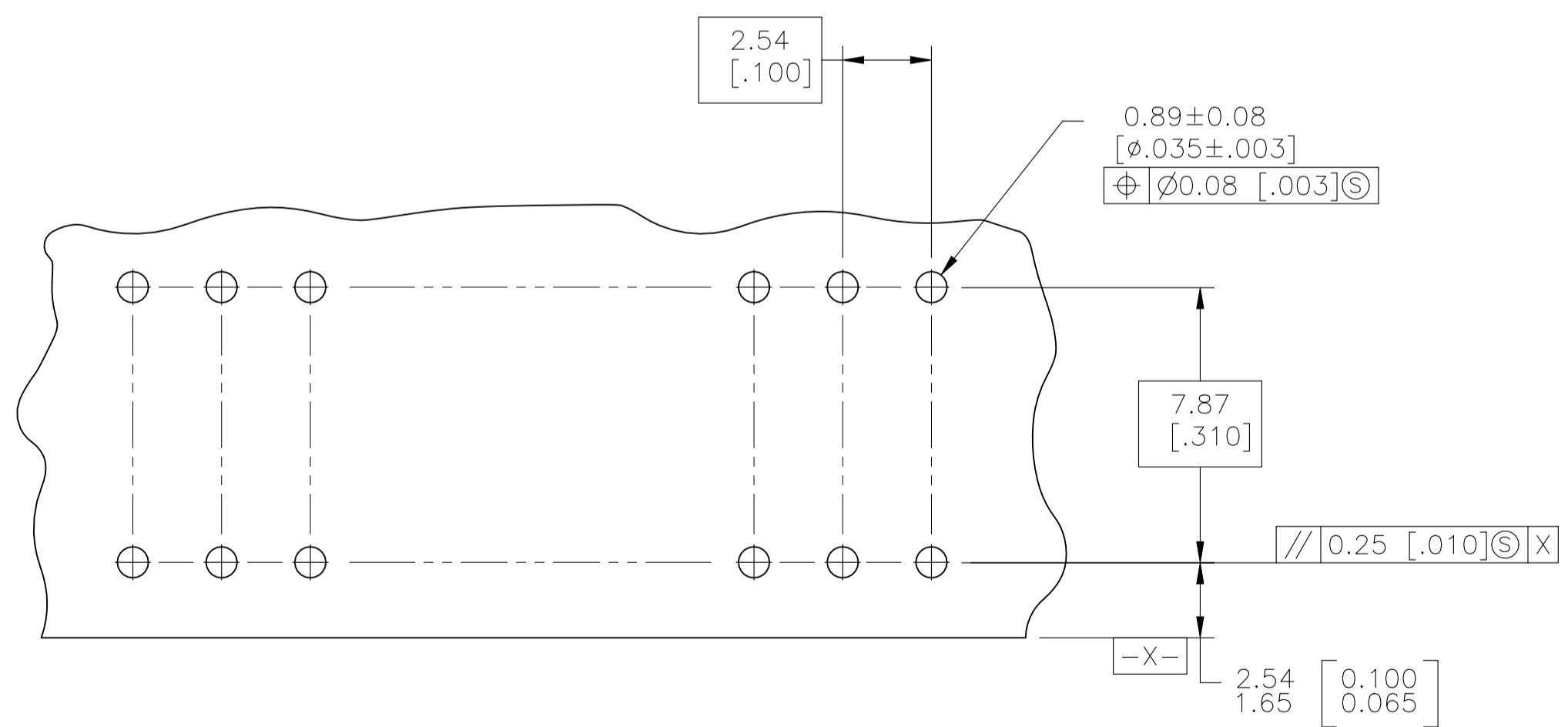
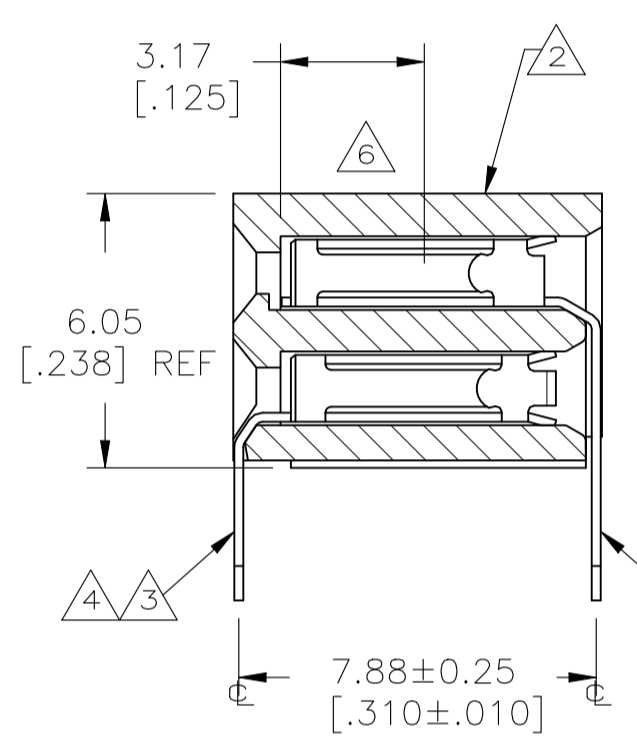
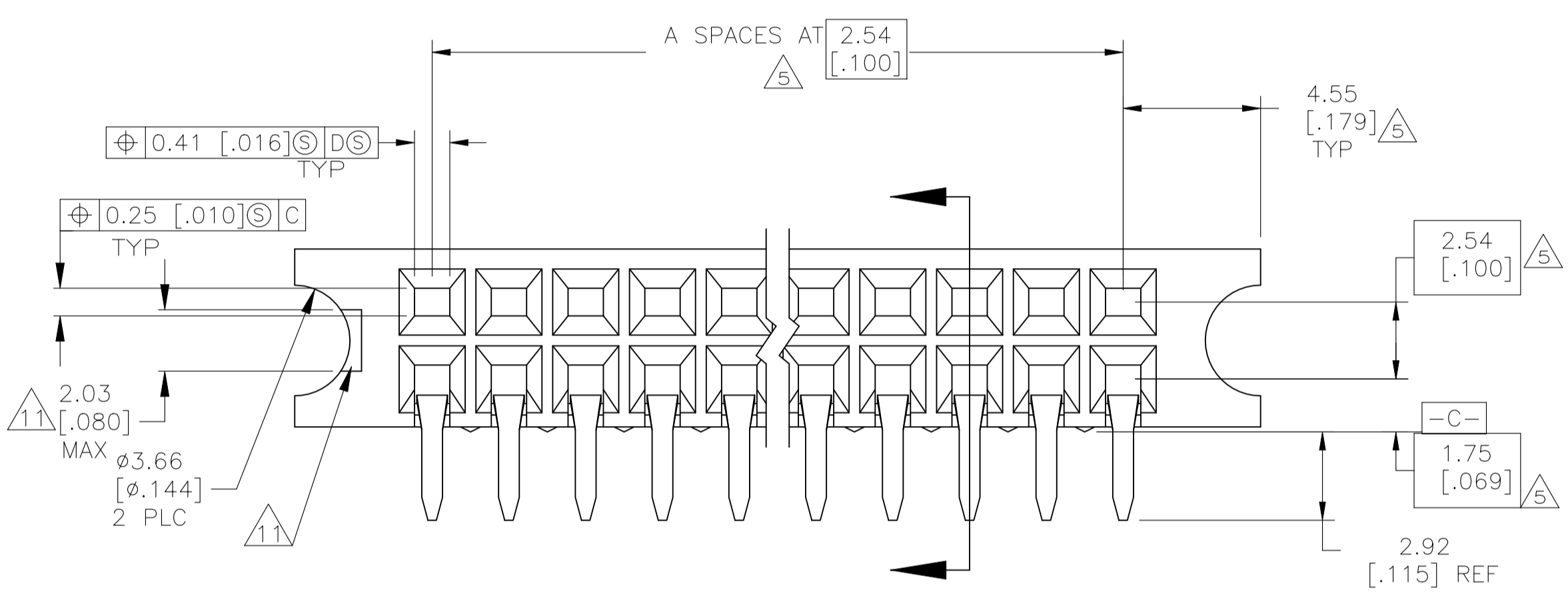
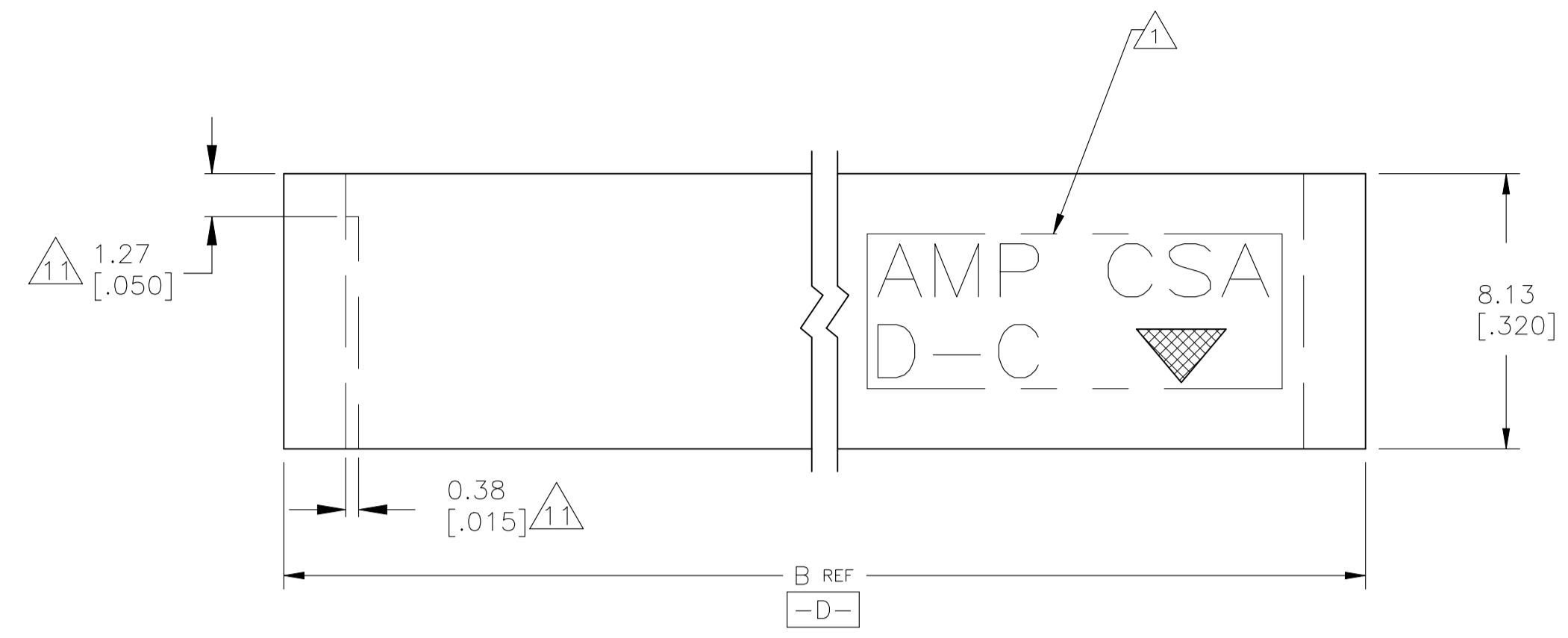

RECOMMENDED P.C. BOARD HOLE LAYOUT

- 1 "AMP", "CSA", "D-C", AND "DATE CODE" WITH .062±.015 HIGH CHARACTERS WHERE SIZE PERMITS.
- 2 HOUSING: LCP MATERIAL
- 3 CONTACT: PHOSPHOR BRONZE.
- 4 CONTACT FINISH: DUPLEX PLATED 0.00076 [.000030] GOLD IN CONTACT AREA, 0.00127-0.00254 [.000050-.000100] BRIGHT TIN-LEAD ON SOLDER TAILS, ALL OVER 0.00127 [.000050] NICKEL.
- 5 THESE DIMENSIONS PERTAIN TO CAVITY C'S ONLY, NOT TO CONTACT LOCATIONS.
- 6 POINT OF MEASUREMENT FOR PLATING THICKNESS (INSIDE CONTACT BEAMS).
- 7 CSA LOGO INK STAMPED WHITE ON HOUSING.
- 8 PRELIMINARY PART - NOT RELEASED FOR PRODUCTION.
- 9 CONTACT FINISH: DUPLEX PLATED 0.00076 [.000030] GOLD IN CONTACT AREA, 0.00127-0.00254 [.000050-.000100] MATTE TIN ON SOLDER TAILS, ALL OVER 0.00127 [.000050] NICKEL.
- 10 ROHS 2002/95/EC COMPLIANT.
- 11 RECESSED AREA AROUND MOLD GATE IS OPTIONAL. THIS FEATURE IS ALLOWABLE ON EITHER SIDE OF HOUSING OR MAY NOT BE PRESENT AT ALL.
- 12 OBSOLETE PARTS: OBSOLETE CIS STREAMLINING PER D.RENAUD/D.SINISI

FINISH	B	A	NO OF POSN	PART NUMBER
OBSOLETE	34.49 [1.358]	10	22	8-532956-0
OBSOLETE	39.57 [1.558]	12	26	7-532956-9
OBSOLETE	62.43 [2.458]	21	44	7-532956-8
OBSOLETE		79	160	7-532956-7
OBSOLETE	24.33 [.958]	6	14	7-532956-6
OBSOLETE	24.33 [.958]	6	14	7-532956-5
OBSOLETE	235.15 [9.258]	89	180	7-532956-4
OBSOLETE	260.55 [10.258]	99	200	7-532956-3
OBSOLETE	194.51 [7.658]	73	148	7-532956-2
OBSOLETE	184.35 [7.258]	69	140	7-532956-1
OBSOLETE	171.65 [6.758]	64	130	7-532956-0
OBSOLETE	169.11 [6.658]	63	128	6-532956-9
OBSOLETE	158.95 [6.258]	59	120	6-532956-8
OBSOLETE	146.25 [5.758]	54	110	6-532956-7
OBSOLETE	133.55 [5.258]	49	100	6-532956-6
OBSOLETE	128.47 [5.058]	47	96	6-532956-5
OBSOLETE	120.85 [4.758]	44	90	6-532956-4
OBSOLETE	113.23 [4.558]	42	86	6-532956-3
OBSOLETE	108.15 [4.258]	39	80	6-532956-2
OBSOLETE	97.99 [3.858]	35	72	6-532956-1
OBSOLETE	95.45 [3.758]	34	70	6-532956-0
OBSOLETE	82.75 [3.258]	29	60	5-532956-9
OBSOLETE	70.05 [2.758]	24	50	5-532956-8
OBSOLETE	57.35 [2.258]	19	40	5-532956-7
OBSOLETE	52.27 [2.058]	17	36	5-532956-6
OBSOLETE	44.65 [1.758]	14	30	5-532956-5
OBSOLETE	37.03 [1.458]	11	24	5-532956-4
OBSOLETE	31.95 [1.258]	9	20	5-532956-3
OBSOLETE	26.87 [1.058]	7	16	5-532956-2
OBSOLETE	21.79 [.858]	5	12	5-532956-1

FINISH	B	A	NO OF POSN	PART NUMBER
OBSOLETE	34.49 [1.358]	10	22	3-532956-0
OBSOLETE	39.57 [1.558]	12	26	2-532956-9
OBSOLETE	62.43 [2.458]	21	44	2-532956-8
OBSOLETE				2-532956-7
OBSOLETE				2-532956-6
OBSOLETE	24.33 [.958]	6	14	2-532956-5
OBSOLETE	235.15 [9.258]	89	180	2-532956-4
OBSOLETE	260.55 [10.258]	99	200	2-532956-3
OBSOLETE	194.51 [7.658]	73	148	2-532956-2
OBSOLETE	184.35 [7.258]	69	140	2-532956-1
OBSOLETE	171.65 [6.758]	64	130	2-532956-0
OBSOLETE	169.11 [6.658]	63	128	1-532956-9
OBSOLETE	158.95 [6.258]	59	120	1-532956-8
OBSOLETE	146.25 [5.758]	54	110	1-532956-7
OBSOLETE	133.55 [5.258]	49	100	1-532956-6
OBSOLETE	128.47 [5.058]	47	96	1-532956-5
OBSOLETE	120.85 [4.758]	44	90	1-532956-4
OBSOLETE	113.23 [4.558]	42	86	1-532956-3
OBSOLETE	108.15 [4.258]	39	80	1-532956-2
OBSOLETE	97.99 [3.858]	35	72	1-532956-1
OBSOLETE	95.45 [3.758]	34	70	1-532956-0
OBSOLETE	82.75 [3.258]	29	60	532956-9
OBSOLETE	70.05 [2.758]	24	50	532956-8
OBSOLETE	57.35 [2.258]	19	40	532956-7
OBSOLETE	52.27 [2.058]	17	36	532956-6
OBSOLETE	44.65 [1.758]	14	30	532956-5
OBSOLETE	37.03 [1.458]	11	24	532956-4
OBSOLETE	31.95 [1.258]	9	20	532956-3
OBSOLETE	26.87 [1.058]	7	16	532956-2
OBSOLETE	21.79 [.858]	5	12	532956-1

THIS DRAWING IS A CONTROLLED DOCUMENT. 17JAN01  
K.L.CLOUSER/UTA  
05/14/91

DIMENSIONS: mm [INCHES] TOLERANCES UNLESS OTHERWISE SPECIFIED:

0 PLC	± .005
1 PLC	± .005
2 PLC	± .013 [.005]
3 PLC	± .013 [.005]
4 PLC	± .013 [.005]
ANGLES	± .013 [.005]

MATERIAL: HOUSING: 2 CONTACT: 3 SEE TABLE

APPROVED: DON FORKER 05/15/91 NAME: RCPT ASSY, MOD II, DBL ROW, 2.54 X 2.54 [.100 X .100] CL, GUIDE PIN EARS.

SIZE: A1 CAGE CODE: 00779 DRAWING NO: 532956 RESTRICTED TO: CUSTOMER DRAWING SCALE: 6:1 SHEET 1 OF 1 REV: AG