

NRG3/NRG4/NRG5

The NRG MID POWER SERIES modular power solution utilizes standard off the shelf power modules configured to customer requirements. Products are available from 350 to 550 watts. This flexible power system is delivered completely configured, burned-in, and tested.



FEATURES

- Fully modular design
- Autoselect AC input
- Up to seven outputs
- Wide selection of voltages/currents
- (FCC) 47CFR15J, EN55022 EMI/RFI
- VME compatible signals
- UL1950 & EN60950 certifications
- Fully regulated outputs
- High power auxiliary outputs
- Adjustable auxiliary outputs
- Power fail signal
- Industry standard mounting
- Fully isolated outputs

OPTIONS

- Fan
- EN60601/UL2601 certifications
- Custom interconnect configurations
- Current share/current monitor
- Custom interface signals

SELECTION AND CONFIGURATION

1. Choose a chassis based on the required wattage.
2. Choose the output modules. A minimum and maximum of one main module must be specified.
3. For standard products, auxiliary modules are configured in a descending power rating. Auxiliary module #1 should have the highest power rating.
4. Decide on the options. Please consult the factory for special requirements such as logic option boards.
5. Isolated outputs are provided on standard products. Consult factory for other interconnect options.
6. An integral fan is used on the NRG5.
7. When using a C9 module, Aux. #1 and #2 can only be C9 or K0. A C9 cannot be used in the Aux. #3 position. The C9 module can only be used with 5V main modules.
8. A “K0” module must be used to fill blank module locations.
9. The standard auxiliary output connector when using only single output modules is a terminal block. A Molex connector is optional. A Molex must be used on all auxiliary outputs when one or more dual output modules are used.

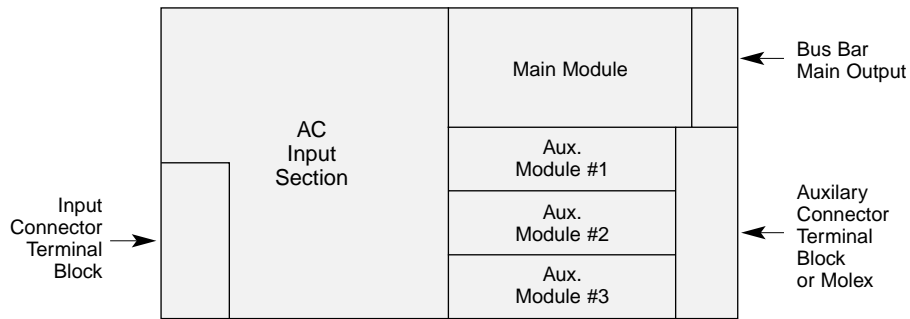

**Physical Location of Modules in the Chassis
Top View**

NRG3/NRG4/NRG5

Mechanical drawings are located at the end of this section.

Example outputs selected: 5V @ 70A, 12V @ 10A, 12V @ 4A, with fan option.

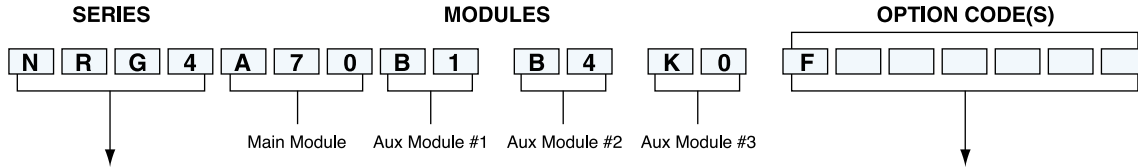

NRG3: 350 Watts Max.
NRG4: 450 Watts Max.
NRG5: 550 Watts Max.

NOTE: The standard terminal block output connector is replaced with a 14-PIN Molex (Part #26-60-4140) when dual output modules are specified. Please consult factory for connector options when specifying a dual output module.

- F - Fan. Add "F" to model number suffix
- AA - Special output connection or interface logic. (A = any alpha letter assigned by Power One).
- SXXX - Modified standard model. (X = any number assigned by Power One).
- V"X" - Molex connector option. Must be used for auxiliary outputs when dual output modules are used. See drawings at the end of this section.

NRG SERIES MID POWER

DC OUTPUT MODULE SELECTOR GUIDE

All blank slots must be filled with a K0 (K zero) module.

NOMINAL VOLTAGE (VO) VDC	MAXIMUM CURRENT (LO) ADC	OUTPUT POWER (PO) W @ 50PC	PART NUMBER	LOCATION
SINGLE OUTPUT MODULES				
2	10	20	F1	Aux.
3.3	10	33	H1	Aux.
5	4	20	A4	Aux.
5	8	40	A8	Aux.
5	10	50	A1	Aux.
5	35	175	A35	Main
5	50	250	A50	Main
5	70	350	A70	Main
5-12	5	25-60	V5	Aux.
12	4	48	B4	Aux.
12	10	120	B1	Aux.
12	30	360	B30	Main
13.5	10	135	BA	Aux.
12-24	3	36-72	W3	Aux.
15	4	60	C4	Aux.
15	9	135	C9	Aux.
15	24	360	C24	Main
24	4	96	D4	Aux.
24	7	168	D7	Aux.
24	15	360	D15	Main
28	13	364	E13	Main
DUAL OUTPUT MODULES; fully isolated, outputs can be referenced independently as + or -				
5/5	1/1	10	A2	Aux.
12/12	1/1	24	B2	Aux.
12/12	2/1	36	N2	Aux.
15/15	1/1	30	C2	Aux.
24/5	1/5	26	D2	Aux.

*Advanced product release, consult factory for availability.

NUCLEAR AND MEDICAL APPLICATIONS Power-One products are not authorized for use as critical components in life support systems, equipment used in hazardous environments, or nuclear control systems without the express written consent of the President of Power-One, Inc.

TECHNICAL REVISIONS The appearance of products, including safety agency certifications pictured on labels, may change depending on the date manufactured. Specifications are subject to change without notice.

NRG3/NRG4/NRG5

INPUT

PARAMETER	CONDITIONS	MIN.	NOM.	MAX.	UNITS
Input Voltage	Auto line select from 115 VAC to 220 VAC.	85	115	132	VAC
		170	220	264	VAC
Input Current	Vin = 85 VAC @ 350W, NRG3.			9.8	ARMS
	Vin = 85 VAC @ 450W, NRG4.			12.6	ARMS
	Vin = 85 VAC @ 550W, NRG5.			15.4	ARMS
Inrush Current	Vin = 220 VAC.		73		APK
	Vin = 115 VAC.		38		APK
Start Up Time	Upon AC turn-on.			0.5	Sec
Input Frequency	With AC input.	47		63	Hz
Hold Up Time	After last AC line peak @ 110/230 VAC	20			mS
Input Power Fail Warning	Warning time given before loss of regulation due to loss of input power.	4			mS
Thermal Shut-Down Protection	Power supply is protected against damage from operation at elevated temperatures. Thermal shutdown is automatically reset.				

SAFETY AND EMI

Agency Approvals	UL 1950 - full compliance without D3 deviations. VDE 0805 (TÜV). CSA C22.2 #950. EN 60950 (TÜV).				
Dielectric Withstand	Input to output. Input to chassis ("Y" caps disconnected). Output to chassis.	Certified to agency approvals as stated above.			
Safety Spacings	Spacing primary to secondary.	8			mm
	Primary to chassis.	4			mm
Leakage Current	264 VAC, 63Hz. Per UL 1950.			1.5	mA
Electro-Magnetic Interference Margin	(FCC) 47CFR15J, EN55022.		6		dB μ V

GENERAL

Output Power	NRG3.			350	W
	NRG4.			450	W
	NRG5.			550	W
Efficiency	Full load, 85-264 VAC.		70		%
Vibration-Operating	5-32 Hz and 32-5 Hz, Sinusoidal.			.02	in(DA)
	32-2000 Hz and 2000-32 Hz, Sinusoidal			1.0	GPK
Vibration-Non Operating	10 to 350 Hz.			.04	G ² /Hz
	350 to 2000 Hz, 6.15 GRMS overall.			.007	G ² /Hz
Shock-Operating	10 \pm 3 mS, 3 axis, Half Sine.			20	GPK
Shock-Non Operating	10 \pm 3 mS, 3 axis, Half Sine.			40	GPK
Drop Test	In shipping container, all 6 faces, 3 edges, one corner.		30		Inches
Operating Temperature	Derate linearly to 50% of Po from 50 to 70°C ambient.	0		50	°C
				70	
Storage Temperature		-40		85	°C
Altitude	Operating.			10,000	Feet
	Non-operating.			40,000	Feet
Relative Humidity	Non-condensing.	0		95	%
External Cooling Air Velocity	Measured 1/4" above and @ the middle of the chassis.	NRG3	300		LFM
		NRG4	400		LFM
		NRG5	factory supplied fan		

NRG3/NRG4/NRG5

DC OUTPUT MODULE SPECIFICATIONS

PARAMETER	CONDITIONS/DESCRIPTION	MIN	NOM	MAX	UNITS
Ambient Temperature	100% load.	0		50	°C
	Derate linearly to 50% of rated power.	0		70	
Initial V0 Setting	Factory set: Main modules.			±1	%
	Single output aux. modules.			±1	
	Dual output aux. modules.			±1	
Output Voltage Adjustment	Nominal line and load. See note 4.			±10	%
Remote Sense Cable Drop	Available in main modules only. See note 5.			0.25	V
Remote Margin Adjustment	Available in main modules only.			±10	%
Line Regulation	85 to 132 VAC, 170 to 264 VAC.			±0.1	%
Load Regulation	0 to 100% load with remote sense.			±0.1	%
	0 to 100% load without remote sense.			±0.4	
Minimum Load	See note 1.	0			%
Cross Regulation	All conditions.			±0.1	%
Current Limit (Factory Set)	Single output modules (main and aux.)	105	120	130	%
	Dual output modules.			3	A
Short Circuit Current	Single output aux. modules.			130	%
	Dual output aux. modules.			3	A
	Main modules hiccup during short circuit.				
Overvoltage Protection	Main module - Entire supply latches off. AC cycle to reset.	125		132	%
	Aux. module - Crowbar type. Entire supply hiccups.	125		132	A
	Dual module - no OVP available.	N/A		N/A	
Reverse Voltage Protection - Current	Reverse voltage supplied by external source or short circuit.			100	%
Differential Mode	V0 >12V. See note 2.			50	mVpp
Noise & Ripple	V0 >12V. See note 2.			100	mVpp
Common Mode	20 MHz bandwidth with a 10 to 1 probe across a 10µH inductance, output return to chassis.			250	mVpp
Overshoot	Turn-on			0.0	mV
Peak Deviation During Load Transients	25% step load / 10% minimum load.			3	%
	Current slew rate 0.5A/µSec				
	Recovery to 1% within 1 mSec				
AC Turn-On Delay	Within 1% of V0			0.5	Sec
Rise Time	10-90% of V0			100	mS
Turn-Off Delay	After inhibit or OVP trip.			1	mS
Fall Time	100% load.			2	mS

INTERFACE SIGNAL SPECIFICATIONS

PARAMETER	CONDITIONS/DESCRIPTION	MIN	NOM	MAX	UNITS
Remote Inhibit (Note 3)	Active low - TTL compatible, referenced to negative sense.				
Current Monitor	Analog output proportional to main output current.	0.1		5.25	V
Current Share	Main module only. Connect for current sharing between main modules for up to 10 units. Consult factory.				
Power Fail	Active low - TTL compatible AC fail and thermal shut down.				

*Adjustment range.

- NOTES:**
- 1) 10% minimum load on the main module is necessary for aux. regulation.
 - 2) Measured at the output terminals with 20MHz bandwidth with a 10 to 1 tipsleeve probe.
 - 3) Inhibits the entire power supply.
 - 4) V5 and W3 are adjustable per modular specifications.
 - 5) For remote sense on aux. modules consult factory.

NRG3/NRG4/NRG5

MODULAR NRG CONNECTOR OPTIONS

A Molex connector is optional for configurations using only single output modules. This only applies to auxiliary outputs. The main output connector is a bus bar.

Configurations using one or more dual output modules must use one of the Molex output options mentioned below. This only applies to auxiliary outputs. The main output connector is a bus bar.

The auxiliary output sequence on the Molex connector can be tailored to your application. Please consult the factory for customized auxiliary output connector sequences.

To specify a Molex output configuration, a V “X” is added to the model number suffix. The “X” designates an output connector option from the table below.

The first three rows in this table designate the auxiliary modules being used. The first column is for configurations with only single output modules. The last column is for configurations with only dual output modules. The output voltage and polarity can be found in the rows below the option designator. The option designator is added as a suffix to the NRG model number.

MODULAR NRG AUXILIARY OUTPUT CONNECTOR OPTIONS

MODULE ONE TYPE MODULE TWO TYPE MODULE THREE TYPE	SINGLE SINGLE SINGLE	SINGLE SINGLE DUAL	SINGLE DUAL SINGLE	SINGLE DUAL DUAL	DUAL SINGLE SINGLE	DUAL SINGLE DUAL	DUAL DUAL SINGLE	DUAL DUAL DUAL
OPTION DESIGNATOR	VJ	VD	VE	VF	VG	VH	VC	VI
MOLEX POSITION#1	V2+	V2+	V2+	V2+	V2-	V2-	V2-	V2-
MOLEX POSITION#2	V2+	V2+	V2+	V2+	V2+	V2+	V2+	V2+
MOLEX POSITION#3	V2-	V2-	V2-	V2-	V3+	V3+	V3+	V3+
MOLEX POSITION#4	V2-	V2-	V2-	V2-	V3-	V3-	V3-	V3-
MOLEX POSITION#5	V3+	V3+	V3-	V3-	V4+	V4+	V4-	V4-
MOLEX POSITION#6	V3+	V3+	V3+	V3+	V4+	V4+	V4+	V4+
MOLEX POSITION#7	V3-	V3-	V4+	V4+	V4-	V4-	V5+	V5+
MOLEX POSITION#8	V3-	V3-	V4-	V4-	V4-	V4-	V5-	V5-
MOLEX POSITION#9	V4+	V4-	V5+	V5-	V5+	V5-	V6+	V6-
MOLEX POSITION#10	V4+	V4+	V5+	V5+	V5+	V5+	V6+	V6+
MOLEX POSITION#11	V4-	V5+	V5-	V6+	V5-	V6+	V6-	V7+
MOLEX POSITION#12	V4-	V5-	V5-	V6-	V5-	V6-	V6-	V7-

The output connector is a 14 pin Molex P/N 26-60-4140. Mating connector housing is 09-50-7141. Mating pins are 08-50-0106.

DESCRIPTION OF P1 AND P4 INTERFACE SIGNAL CONNECTORS

These two interface connectors are located next to the main module as noted in the mechanical drawing found on the following page. The pin designations for these connectors are as follows:

CONNECTOR	PIN	FUNCTION	MATING CONNECTOR
P1	1	+ Sense	
	2	- Sense	
	3	Inhibit	Mating housing is Molex part #50-37-5063.
	4	Current monitor	Mating pins are Molex part #08-70-1040.
	5	Current share	
	6	Power fail	
P4	1	+18V internal bias	Mating housing is Molex part #50-37-5033.
	2	Synchronization	Mating pins are Molex part #08-70-1040.
	3	Margin/remote adjust	

Please consult factory for proper use of signals on pins 1 and 2 of connector P4.

For the Most Up-To-Date Information

www.power-one.com

24 Hours/Day—7 Days/Week



NRG3/NRG4/NRG5

OVERALL SIZE: 10.50" x 5.00" x 2.50" (266.7mm x 127.0mm x 63.5mm)

OVERALL LENGTH WITH FAN: 12.00" (305.0mm)

WEIGHT: 4.00 LBS (1.8 kg)

OPTIONAL MOLEX OUTPUT CONNECTOR
 MOLEX PART# 26-60-4140
 MATING HOUSING PART# 09-50-3141
 MATING PIN PART# 08-50-0116

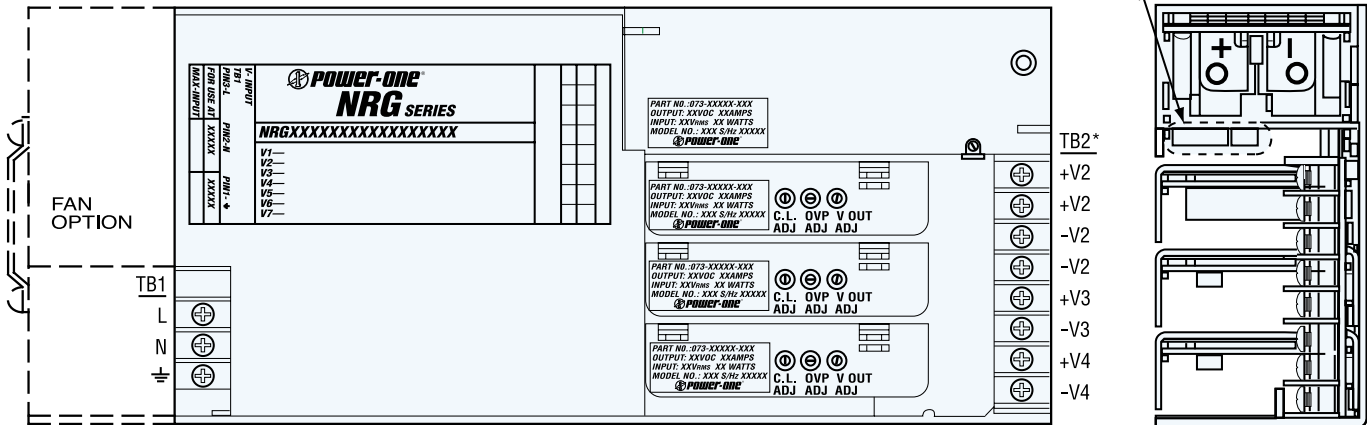
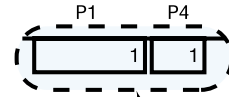

THE AC CONNECTOR IS MOUNTED FLUSH TO THE FAN END OF THE POWER SUPPLY WHEN THE FAN OPTION IS SPECIFIED.

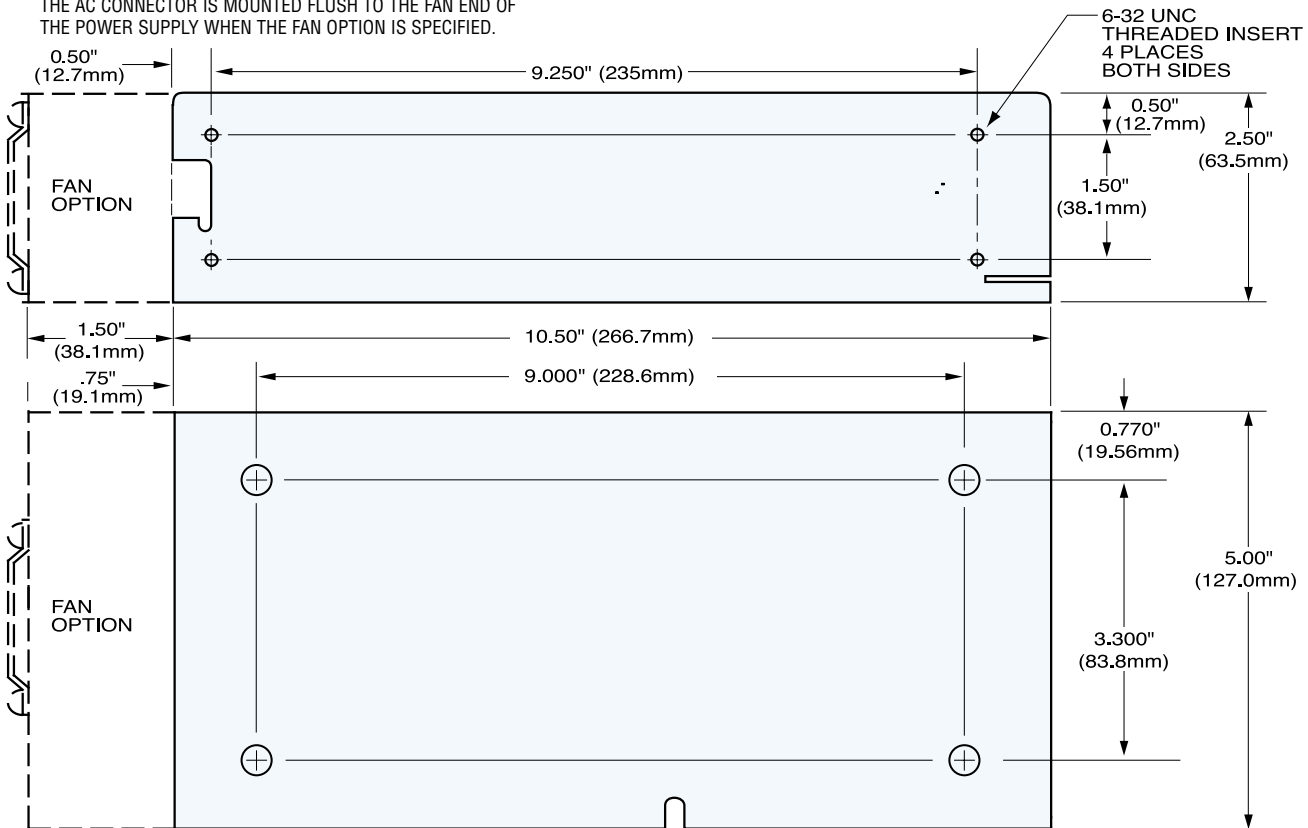

*V2, V3, V4 ARE ISOLATED WITH POLARITIES AS SHOWN IN STANDARD CONFIGURATION. CONSULT FACTORY FOR OTHER AVAILABLE POLARITIES AND INTERCONNECTS.