

THIS DRAWING IS UNPUBLISHED. RELEASED FOR PUBLICATION
 © COPYRIGHT BY TYCO ELECTRONICS CORPORATION. ALL RIGHTS RESERVED.

LOC	DIST	REVISIONS			
P	LTR	DESCRIPTION	DATE	DWN	APVD
AJ	00	B	REV PER ECO 07-027471	1/17/2008	DW JL

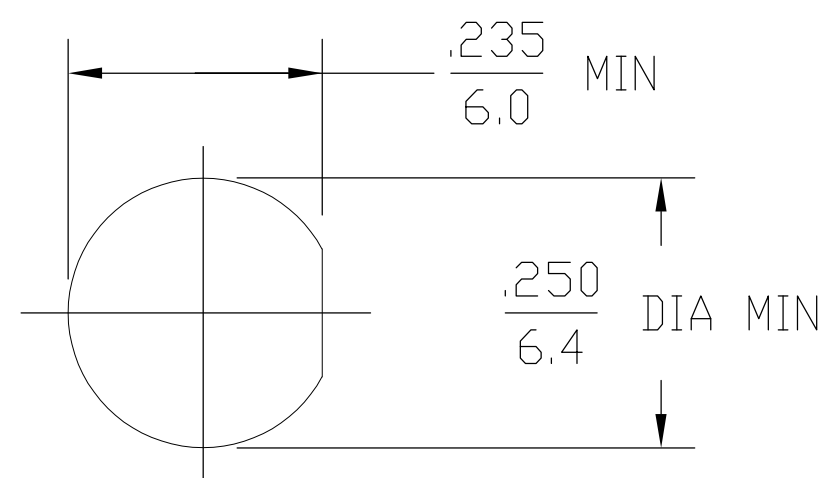
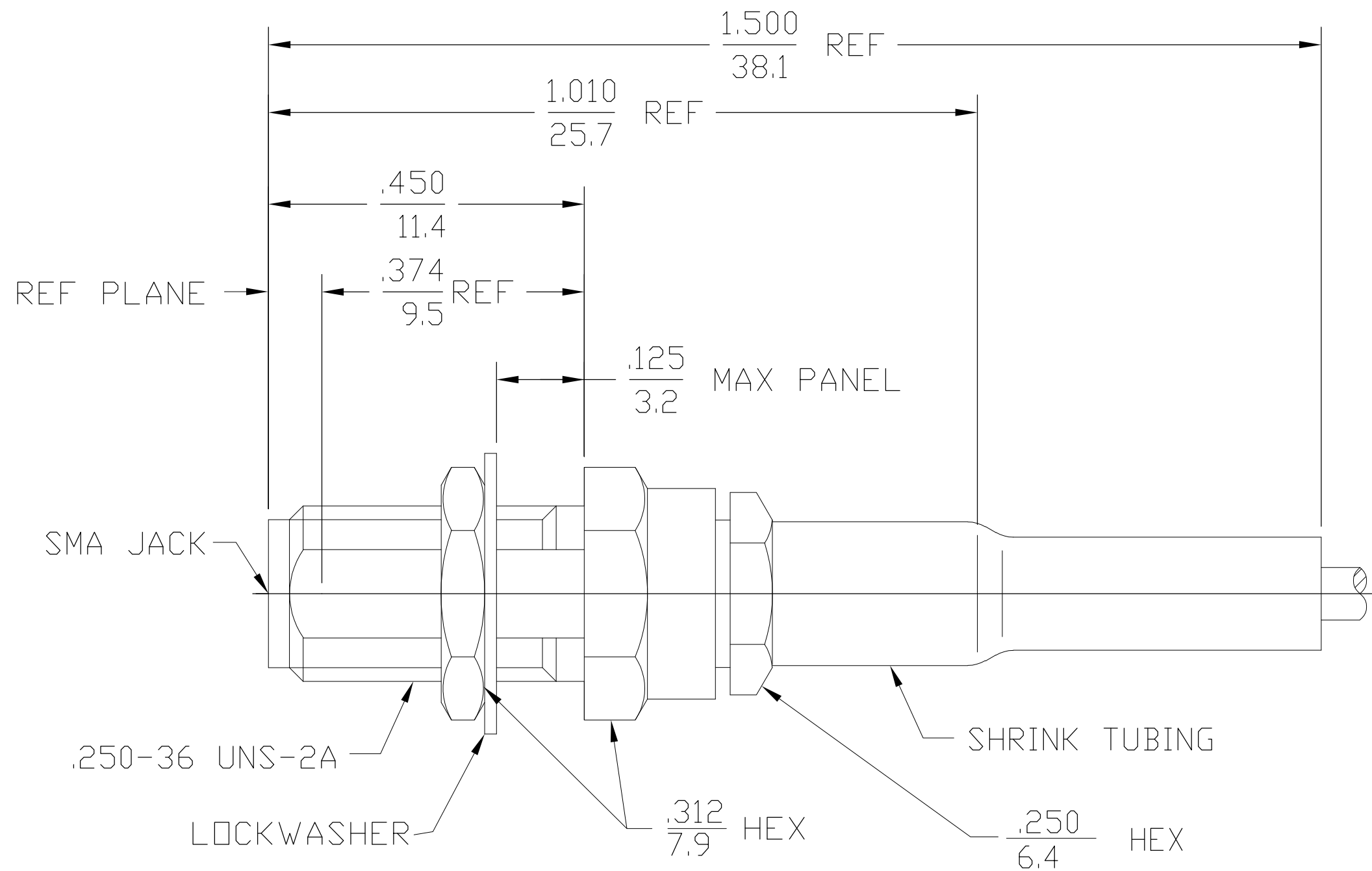

RECOMMENDED MOUNTING HOLE

1051950-1
PART NUMBER

DESIGNED FOR USE WITH RG178/U & SIMILAR CABLES	
CABLE ENTRY DIAMETER MINIMUM	
CONTACT	.021
SLEEVE	.036
FERRULE	.098

ELECTRICAL	MECHANICAL	ENVIRONMENTAL
Nominal Impedance (Ohms) 50	Interface Dimensions MIL-STD-348A, Fig. 310.2	TEMPERATURE RATING -65°C TO +165°C
Frequency Range (GHz) DC to 12.4	Recommended Mating Torque N/A	Vibration MIL-STD-202, Method 204, Condition D
Volt Rating (VRMS MAX) @ Sea Level 170	Mating Characteristics:	Shock MIL-STD-202, Method 213, Condition I
VSWR 1.20 + [0.02 f(GHz)]	Insertion (MAX Lbs) 3.0	Thermal Shock MIL-STD-202, Method 107, Condition B
Insertion Loss (dB MAX) .06 √ f(GHz)	Withdrawal (MIN Oz) 1.0	EXCEPT HIGH TEMP SHALL BE +85°C
RF Leakage (dB MIN) -60 @ 2-3 GHz	Force to Engage and Disengage (In/Lbs MAX) 2.0	Moisture Resistance MIL-STD-202, Method 106, Except Vibration
Corona, 70,000 Ft (VRMS MIN) 125	Center Contact Captivation	Shall Be Omitted
Dielectric Withstanding Voltage (VRMS MIN) @ Sea Level 500	Axial (Lbs) 6.0	Corrosion - MIL-STD-202, Method 101, Condition B, 5% salt spray
Contact Resistance (Milliohms MAX)	Radial (In/Oz) N/A	
Center Contact 2.0	Cable Retention	
Outer Contact 2.0	Axial Force (Lbs) 10.0	
Cable to Housing 0.5	Torque (In/Oz) N/A	
RF High Potential @ Sea Level (VRMS MIN @ 5 MHz) 335	Weight (Grams) 4.2	
I.R.(Megohms MIN) 10,000		

.XXX = in
XX.X = mm

COMPONENT	MATERIAL	FINISH
HOUSING MOUNTING NUT CLAMP NUT SLEEVE	STAINLESS STEEL PER ASTM-A484 AND ASTM-A582, TYPE 303	GOLD PLATE PER MIL-G-45204
DIELECTRIC	TFE FLUOROCARBON PER ASTM-D-1457	N/A
CENTER CONTACT	BERYLLIUM COPPER PER ASTM B 196, ALLOY C17300, CONDITION H	GOLD PLATE PER MIL-G-45204
LOCKWASHER	PHOSPHOR BRONZE PER QQ-B-750, GRADE B2 OR TIN BRASS PER ASTM-B-591	GOLD PLATE PER MIL-G-45204
O-RING	SILICONE RUBBER PER ZZ-R-765	N/A
SHRINK TUBING	HEAT SHRINKABLE POLYOLEFIN COMPOUND MIL-I-23053/4	N/A
FERRULE	COPPER OR BRASS ALLOY ROCKWELL F65 MAXIMUM	GOLD PLATE PER MIL-G-45204

THIS DRAWING IS A CONTROLLED DOCUMENT.		DWN B.D.W 5-31-88	Tyco Electronics Corporation Harrisburg, PA 17105-3608	
DIMENSIONS: INCHES		CHK M.Y 6/2/88	NAME SMA BULKHEAD FEEDTHRU CABLE JACK CRIMP ATTACHMENT (2034-5031-00)	
TOLERANCES UNLESS OTHERWISE SPECIFIED:		APVD P.H 6/8/88	SIZE A2 CAGE CODE 00779 DRAWING NO. 1051950-1	
0 PLC ± -		PRODUCT SPEC -	RESTRICTED TO -	
1 PLC ± -		APPLICATION SPEC 408-04802	SCALE 1:1 SHEET 1 of 1 REV B	
2 PLC ± -		WEIGHT -		
3 PLC ± .005		CUSTOMER DRAWING		
4 PLC ± - ± 1°				
MATERIAL -				
FINISH -				