

PART NUMBER	REV	FIRST USED
680569-1	A	122500-1
680569-2	A	565435-5
680569-3	A	354500-1

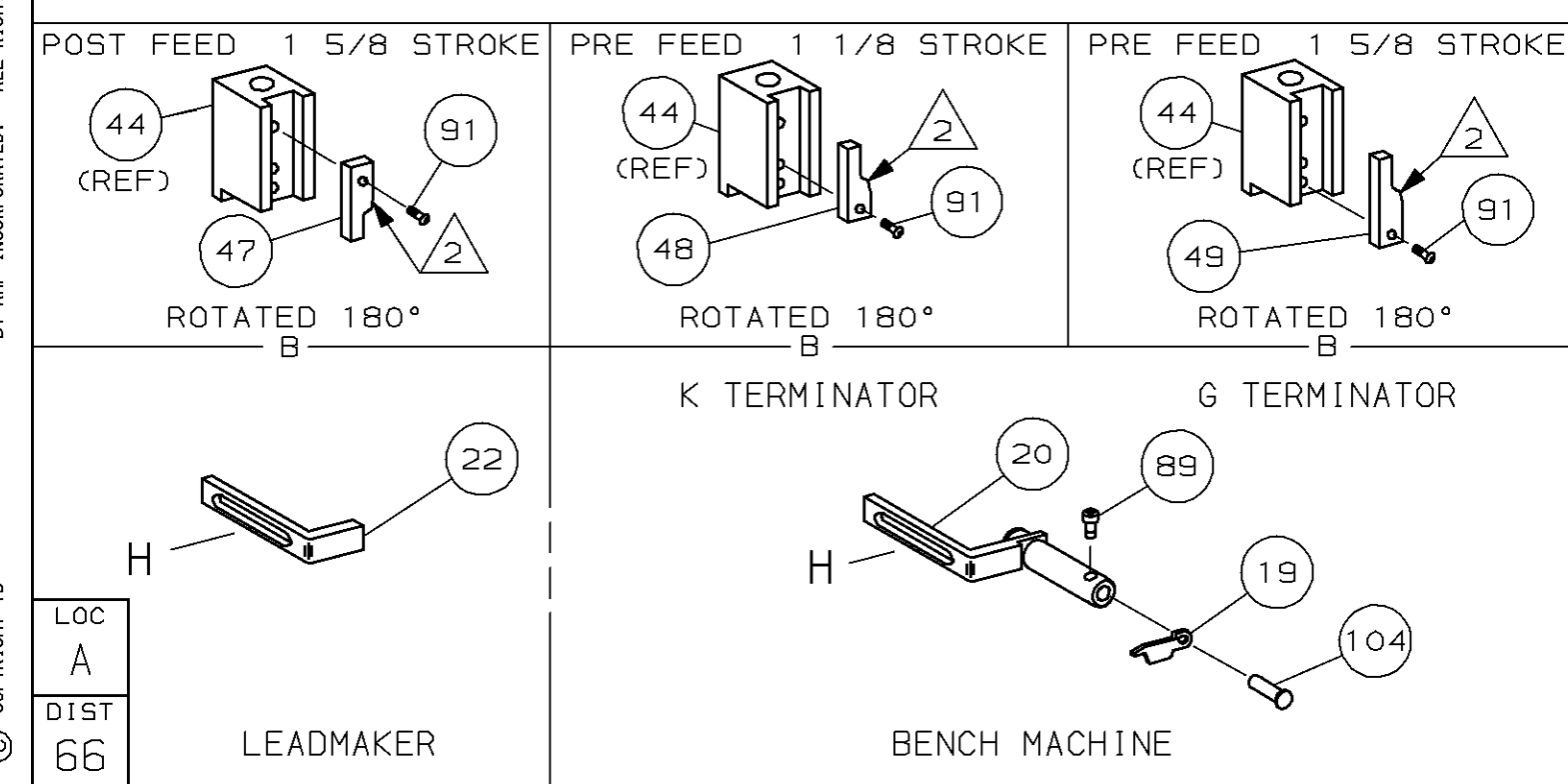
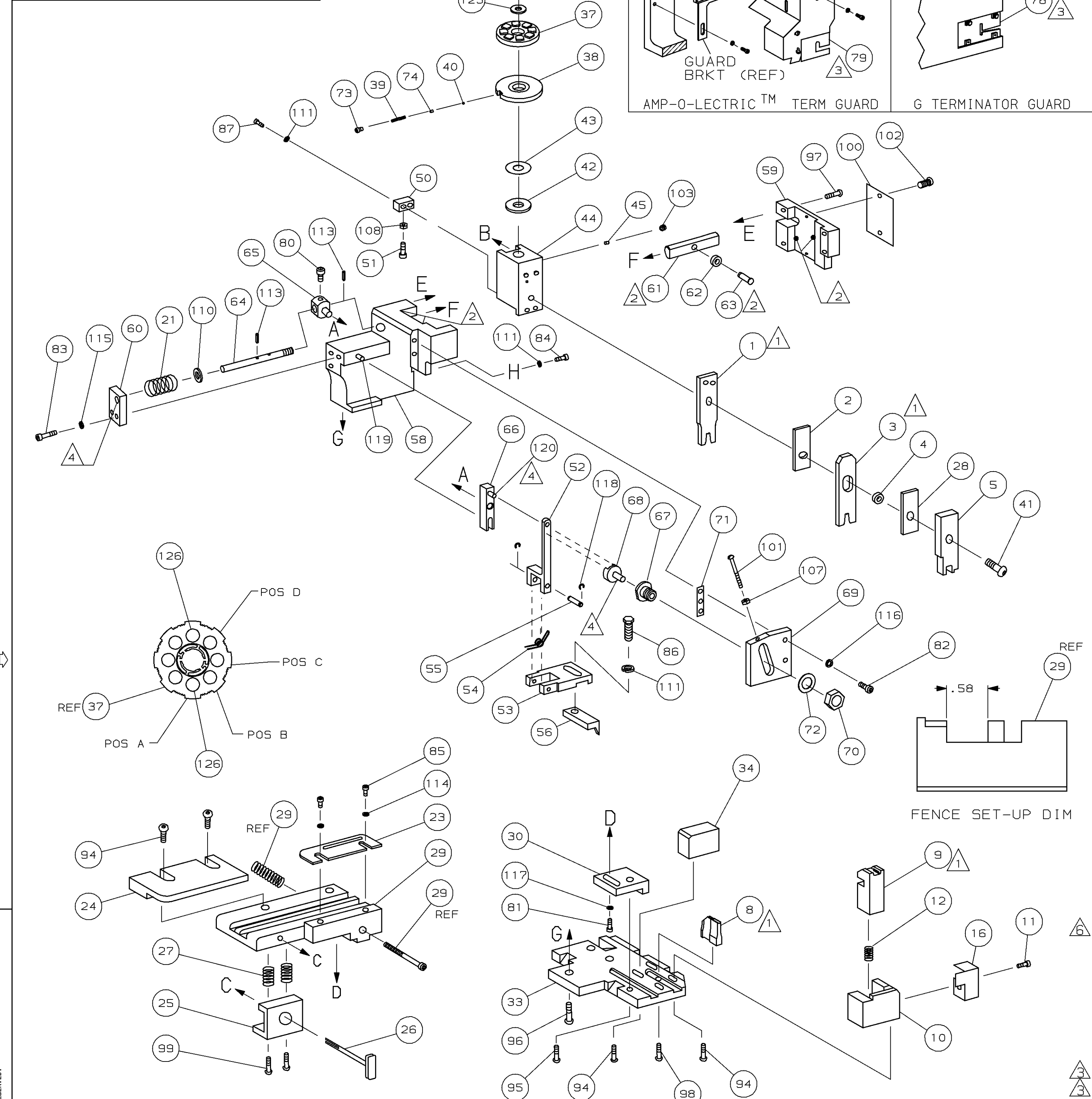

- 1 RECOMMENDED SPARE PARTS.
- 2 GREASE LIGHTLY.
- 3 GUARD MUST BE IN PLACE WHEN OPERATING APPLICATOR IN A BENCH MACHINE.
- 4 LUBRICATE DAILY USING NO. 20 MACHINE OIL.
- 5. ITEMS WITH QTY OF REF SPECIFIED (EXCEPT ITEMS 78 AND 79) ARE USED ON ITEM 46.
- 6 CUT TO LENGTH AT ASSY

TERMINAL NAME: RECEPTACLE			
286677	CRIMP DATA (COMP TERMINAL-CUST SPEC)		
PAD LTR	CRIMP HEIGHT	WIRE SIZE	
A	.033 ±.002 [0.84 ±0.05mm]	22	
B	NOT	USED	
C	NOT	USED	
D	NOT	USED	
CRIMP	SIZE	TYPE	RANGE
WIRE	.070 [1.78mm]	F	22
INSUL	.100 [2.54mm]	0	∅.055-.079

QTY REQD PER ASSY	TERM APPL	SPEC	FEED	APPL INSTRUCTION	SET UP GAGE	LAYOUT	ITEM NO
.188-.219	NONE		.397	408-8040	458637-1	L2021	129
2	2	2	-	C	5-354779-6	PIN, WIRE DISC (.3270)A	126
1	1	1	-	A	986950-1	WASHER, FLAT PRECISION	125
1	1	1	-	A	217238-1	GENERAL INSTRUCTION PACKAGE	124
1	1	1	-	-	4088040	SF APPL INST 408-8040	123
REF	REF	REF	-	A	1-21030-1	PIN, DOWEL (∅.187x.50) LEVER	120
REF	REF	REF	-	A	1-21030-6	PIN, DOWEL (∅.187x1.25) HOUSING	119
REF	REF	REF	-	A	21045-3	RING, RET "C" (∅.187) FD FING PIN	118
1	1	1	-	A	21024-5	WASHER, LOCK (#10) ADJ BLOCK	117
REF	REF	REF	-	A	21024-5	WASHER, LOCK (#10) ADJ PLATE	116
REF	REF	REF	-	A	21024-5	WASHER, LOCK (#10) FEED GDE ROD	115
2	2	2	-	A	21024-2	WASHER, LOCK (#4) FRONT STP GUIDE	114
REF	REF	REF	-	A	5-21028-1	PIN, SLT SPR (∅.125x.50) ADJ ROD	113
4	4	4	-	A	21024-4	WASHER, LOCK (#8) STRIPPER	111
REF	REF	REF	-	A	21899-4	WASHER, FLAT (∅5/16) SCREW ADJ	110
1	1	1	-	A	21018-5	NUT, HEX (NO. 6) HOLDDOWN	109
REF	REF	REF	-	A	21068-5	NUT, HEX (6-32) FEED ADJ	107
1	1	1	-	A	992031-1	PIN, CLEVIS	104
1	1	1	-	A	21009-2	SCR, SKT SET (1/4-20x.25 LW) RAM	103
2	2	2	-	A	21017-2	SCR, DRIVE (#2x.19) ID PLATE	102
REF	REF	REF	-	A	6-23715-5	SCR, PAN HD (6-32x1.50) FEED ADJ	101
1	1	1	-	B	461264-1	PLATE, IDENTIFICATION	100
2	2	2	-	A	3-21002-0	SCR, BHC (10-32x.88) DRAG	99
1	1	1	-	A	22733-8	SCR, BHC (8-32x.38 LW) ANVIL	98
REF	REF	REF	-	A	2-21002-9	SCR, BHC (10-32x.75) CAP	97
REF	REF	REF	-	A	2-22733-8	SCR, BHC (1/4-20x.62) HOUSING	96
REF	REF	REF	-	A	2-21002-7	SCR, BHC (10-32x.50) SG ADJ BLOCK	95
6	6	6	-	A	2-21002-2	SCR, BHC (8-32x.50) TERM H DWN	94
1	1	1	-	A	1-21002-7	SCR, BHC (6-32x.38) CAM	91
1	1	1	-	A	7-21000-9	SCR, SHC (4-40x.19) STRIPPER	89
2	2	2	-	A	2-21000-7	SCR, SHC (8-32x.48) DEP-HOLD	87
1	1	1	-	A	2-22603-0	SCR, HEX HD (8-32x.31) FEED FINGER	86
2	2	2	-	A	1-21000-3	SCR, SHC (4-40x.25) F ST GUIDE	85
1	1	1	-	A	2-21000-7	SCR, SHC (8-32x.50) STRIPPER	84
REF	REF	REF	-	A	3-21000-7	SCR, SHC (10-32x.75) FEED ROD GD	83
REF	REF	REF	-	A	3-21000-6	SCR, SHC (10-32x.62) FD ADJ BLK	82
1	1	1	-	A	7-21000-6	SCR, SHC (10-32x.31) SG ADJ BL	81
REF	REF	REF	-	A	3-21000-4	SCR, SHC (10-32x.38) PIVOT BLK	80
-	REF	-	-	B	455749-1	GUARD, WINDOW	79
REF	-	-	-	B	679532-1	INSERT, GUARD	78
1	1	1	-	A	690603-1	SPRING, ASSIST	74
1	1	1	-	A	23030-1	SCR, SHC (6-32x.25 SL) INS DISC	73
REF	REF	REF	-	A	458109-1	WASHER, SPECIAL	72
REF	REF	REF	-	A	690517-1	SPACER	71

QTY REQD PER ASSY	LEADMAKER	MECH POST FEED	ITEM NO
-1	BENCH MODEL K	MECH PRE FEED	70
-2	BENCH MODEL G	MECH PRE FEED	69
REF	REF	REF	68
REF	REF	REF	67
REF	REF	REF	66
REF	REF	REF	65
REF	REF	REF	64
REF	REF	REF	63
REF	REF	REF	62
REF	REF	REF	61
REF	REF	REF	60
REF	REF	REF	59
REF	REF	REF	58
REF	REF	REF	57
1	1	1	56
REF	REF	REF	55
REF	REF	REF	54
REF	REF	REF	53
REF	REF	REF	52
1	1	1	51
1	1	1	50
1	-	-	49
-	1	-	48
-	-	1	47
1	1	1	46
1	1	1	45
1	1	1	44
1	1	1	43
1	1	1	42
1	1	1	41
1	1	1	40
1	1	1	39
1	1	1	38
1	1	1	37
1	1	1	36
1	1	1	35
1	1	1	34
REF	REF	REF	33
REF	REF	REF	32
REF	REF	REF	30
1	1	1	29
1	1	1	28
2	2	2	27
1	1	1	26
1	1	1	25
1	1	1	24
1	1	1	23
-	-	1	22
REF	REF	REF	21
1	1	-	20
1	1	-	19
1	1	1	18
1	1	1	17
1	1	1	16
1	1	1	15
1	1	1	14
1	1	1	13
1	1	1	12
1	1	1	11
1	1	1	10
1	1	1	9
1	1	1	8
1	1	1	7
1	1	1	6
1	1	1	5
1	1	1	4
1	1	1	3
1	1	1	2
1	1	1	1

REVISION OF EACH ASSY NO (WHEN BLANK, USE DWG REVISION)

QTY REQD PER ASSY	ASSY LIST	MATL	HT TR	FIN
1	1	1	1	1

DIMENSIONS IN INCHES. DO NOT SCALE PRINT. TOLERANCES UNLESS OTHERWISE SPECIFIED.

DR L. COLLINS 15DEC97 APP T. ELBIN 15DEC97

CHK 15DEC97 REL C. ERISMAN

NAME SIDE FEED HDM APPLICATOR MACHINE REF MINI APPL

SCALE 1 OF 1 SHEET REV A

NO 680569

00779 CUSTOMER AND ASSEMBLY DRAWING RESTRICTED TO

THIS DRAWING IS A CONTROLLED DOCUMENT.

THIS DRAWING IS UNPUBLISHED. RELEASED FOR PUBLICATION BY AMP INCORPORATED. ALL RIGHTS RESERVED.