

Mechanical Dimensions: Inches [mm]

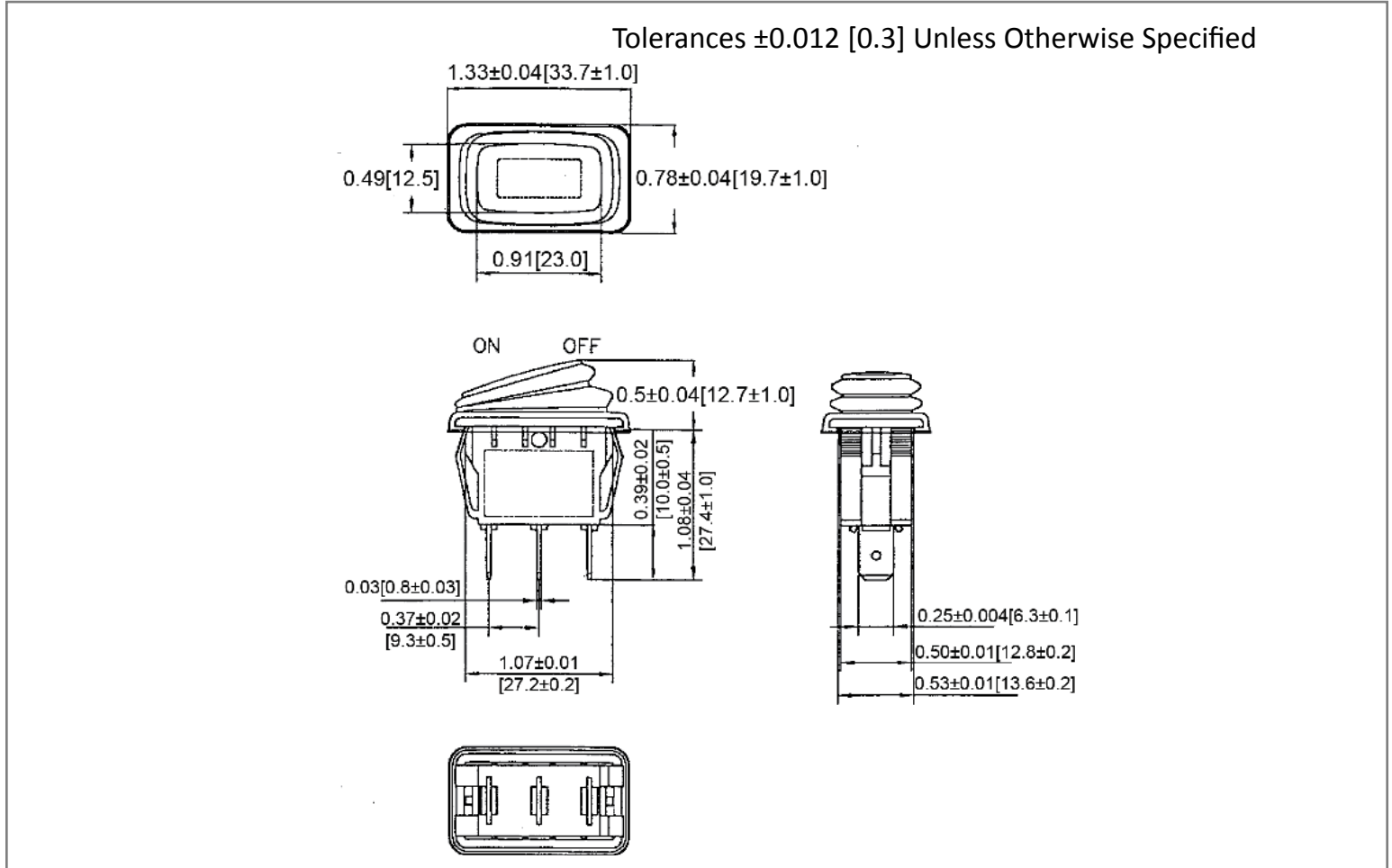

Mounting Hole

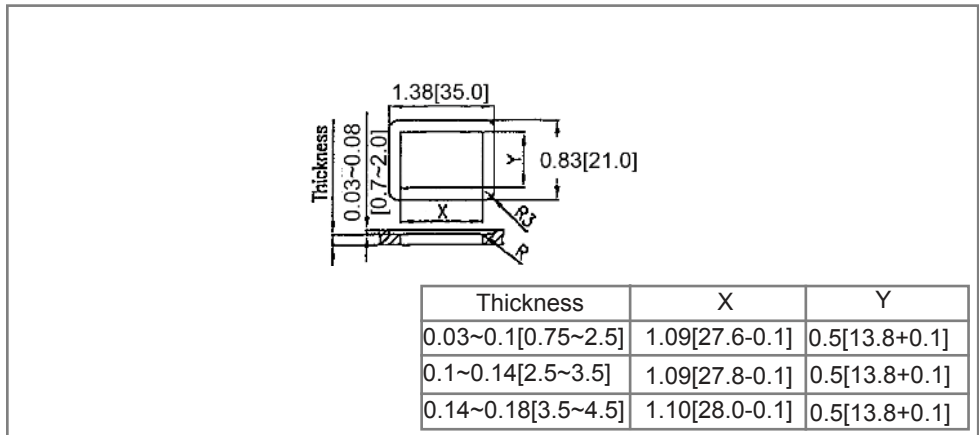

Circuit Diagram

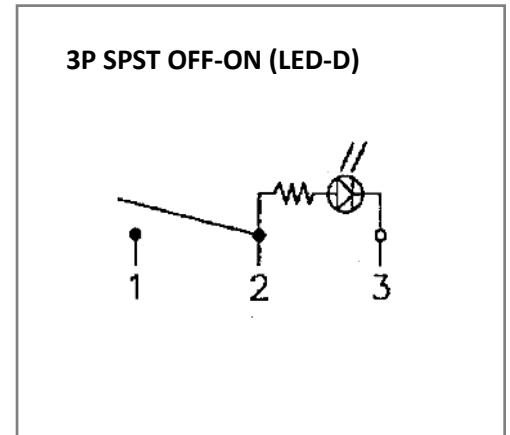

Electrical Specifications

Rating	16A 12VDC	Frame	Black, Nylon 66
Contact Resistance	50m ohm Max.	Actuator	Green, Nylon#66+30%GF
Insulation Resistance	DC 500V 100M ohm Min.	Terminals	1,2: Copper alloy, Silver plated 3: Brass alloy
Dielectric Strength	AC 1500V 1 minute	LED	Green (Dependent)
Operation Temperature	-25° C-85° C	Waterproof	IP65, Black Silicone Rubber

Rev	Date of issue	Revision Notes	Designed	Approved
B	05-04-2020	Initial Drawing	RC	OF