

**IDT
Mini Mi II™ System
Hand Tool**

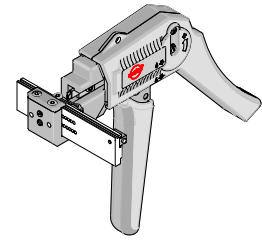

**Application Tooling
Specification Sheet**



Order No. 62100-9800

FEATURES

- Terminates wire directly into the receptacle housing assembly
- Accommodate 2 to 20 circuit connectors
- % A full cycle ratchet ensures complete terminations
- % This tool is designed for prototype or low volume work only and is not intended for production

SCOPE

Products: 1.25mm (.049") Pitch Mini Mi II™ System Wire-to-Board Insulation Displacement Receptacle Housing assemblies. Series 51336 and 54596 (2 to 20-circuits)

Applicable wire: UL10272 AWG 26/28 discrete wire (Insulation O.D 0.8-0.9mm)

Product List

The following is a partial list of the product order numbers that this tool is designed to run. Updates to this list are available on www.molex.com.

Connector Series No.	Connector Order No.					
51336	51336-0210	51336-0310	51336-0410	51336-0510	51336-0610	51336-0710
	51336-0810	51336-0910	51336-1010	51336-1110	51336-1210	51336-1310
	51336-1410	51336-1510	51336-1610	51336-1710	51336-1810	51336-1910
	51336-2010					
54596	54596-0210	54596-0212	54596-0213	54596-0310	54596-0312	54596-0313
	54596-0410	54596-0412	54596-0413	54596-0510	54596-0512	54596-0513
	54596-0610	54596-0612	54596-0613	54596-0710	54596-0712	54596-0713
	54596-0810	54596-0812	54596-0813	54596-0910	54596-0912	54596-0913
	54596-1010	54596-1012	54596-1013	54596-1110	54596-1112	54596-1113
	54596-1210	54596-1212	54596-1213	54596-1310	54596-1312	54596-1313
	54596-1410	54596-1412	54596-1413	54596-1510	54596-1512	54596-1513
	54596-1610	54596-1612	54596-1613	54596-1710	54596-1712	54596-1713
	54596-1810	54596-1812	54596-1813	54596-1910	54596-1912	54596-1913
	54596-2010	54596-2012	54596-2013			

OPERATION

Open the hand tool by squeezing the handles together. At the end of the closing stroke, the ratchet mechanism will and the handle will spring open.

1. Pull back on the spring plunger lock on the connector slide and hold it in place.
2. Place the proper connector into the connector slide; the flat side of the connector should be against the slide, and the slots should be facing up. See Figure 1.
3. Release the spring plunger lock. The spring plunger lock will extend and hold the connector.
4. Insert the connector slide into the track of the hand tool by firmly pushing it over the index locators until an audible "click" is heard. This will be the first position for the first wire. Connectors can be loaded with the connector slide already installed in the tool.

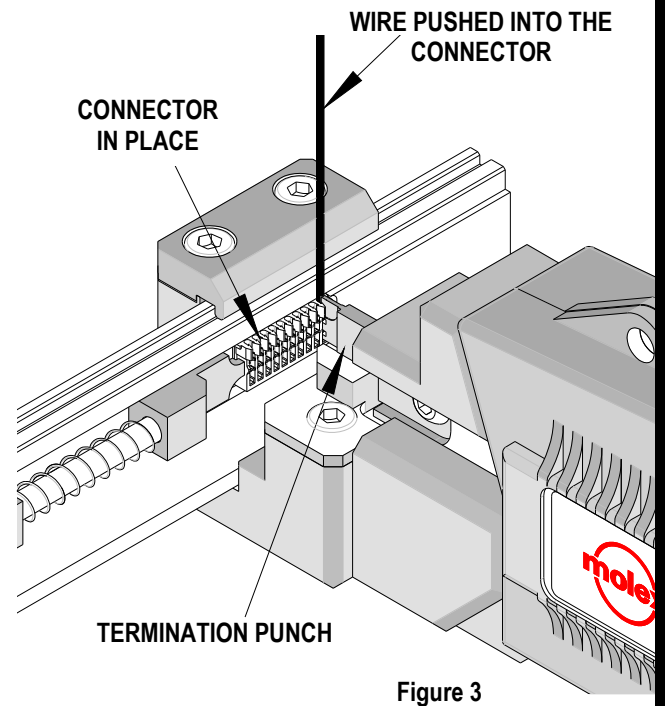
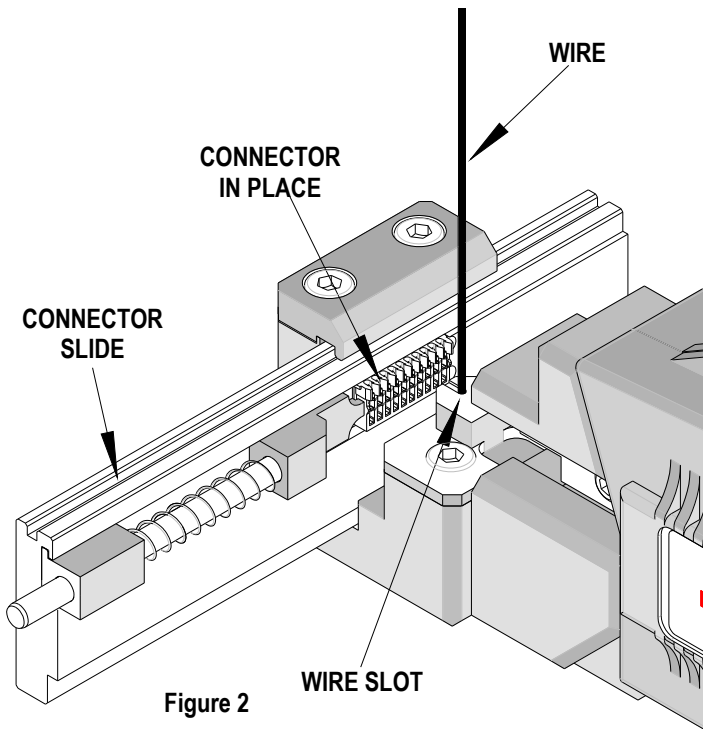
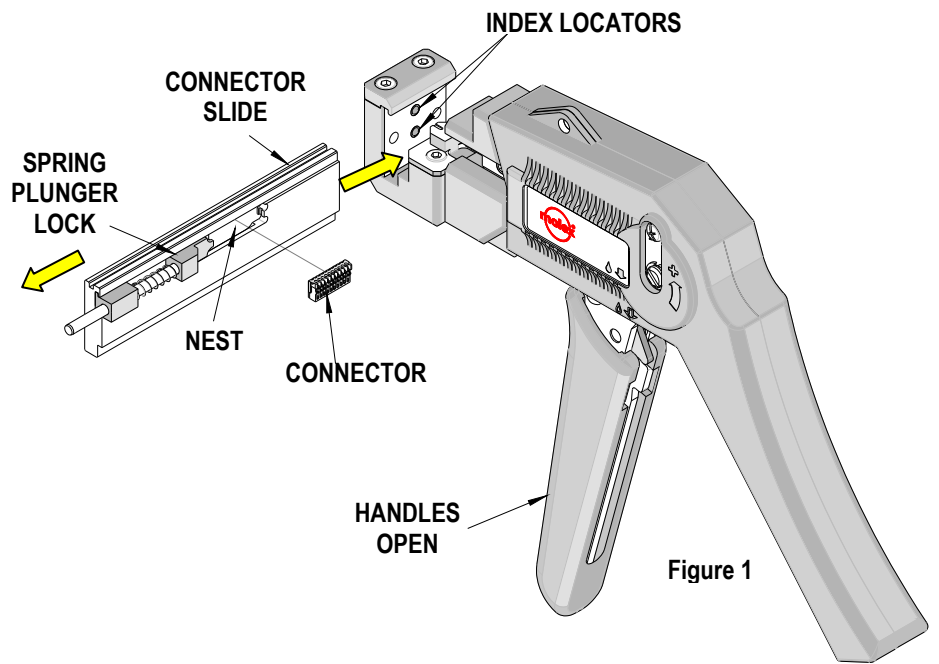

5. Place the first wire into the wire slot until it stops. See Figure 2.
6. While holding the wire in place, squeeze the handles together, the termination punch will terminate the wire into the connector. See figure 3.
7. Continue squeezing the handles together until the ratchet releases.
8. Open the tool handles slowly.

Note: The full cycle ratchet action will not release the tool until it has been fully closed.

Note: If something jams, the ratchet mechanism can be released by pushing upward on the ratchet pawl at the base of the trigger. See Figure 5.

9. Index to the next position by pushing the connector slide over until it stops or “clicks” into position.
10. Repeat steps 5, 6, and 7 until all wires are terminated.
11. Push the connector slide all the way to the left.
12. Pull back on the spring plunger lock on the connector slide and hold down.
13. Remove the completed connector assembly from the slide.

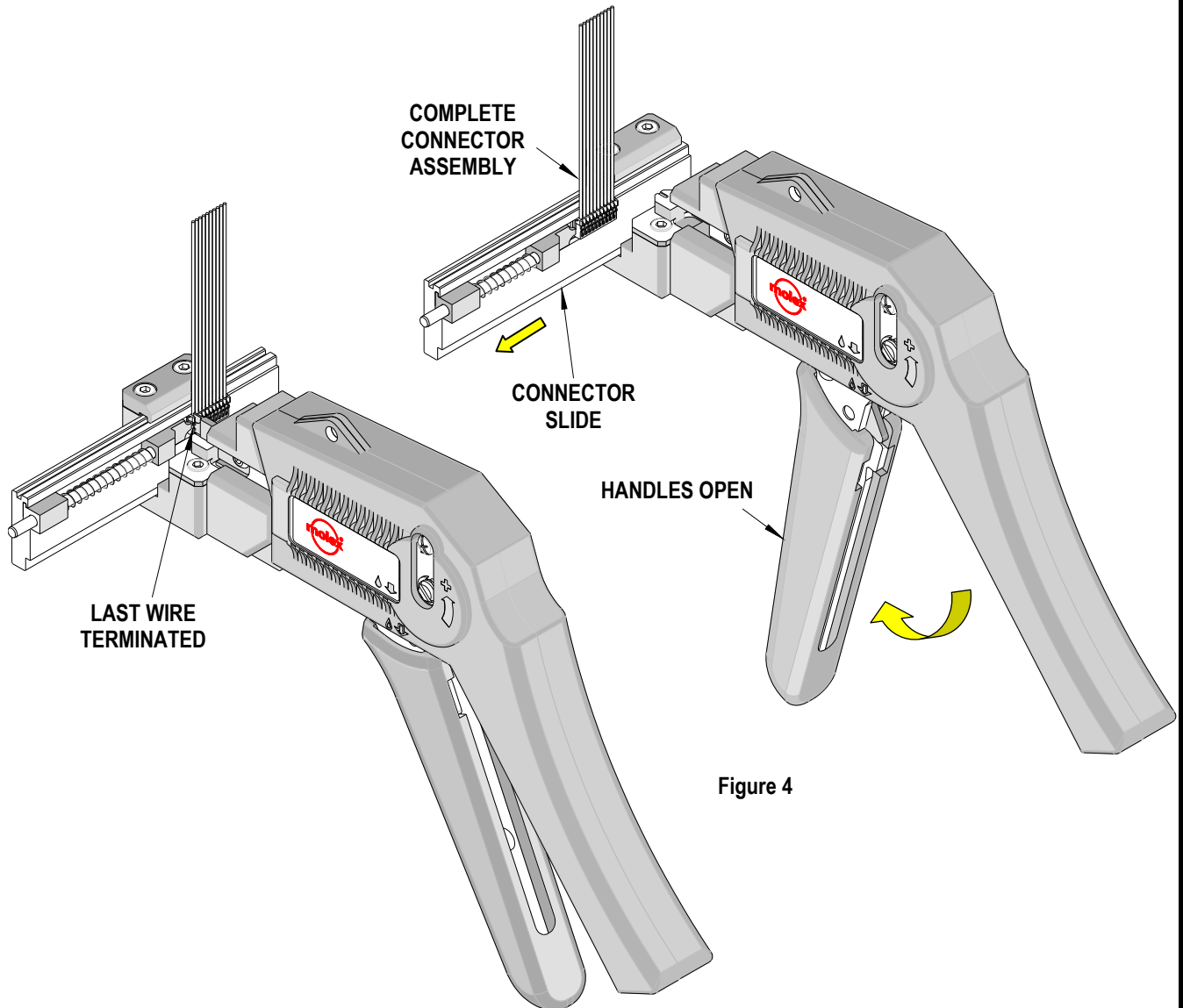

Figure 4

CAUTION: Molex specifications are valid only when used with Molex connectors and tooling.

Maintenance

It is recommended that each operator of the tool be made aware of, and responsible for, the following maintenance steps:

1. Remove the plastic handles from the metal tool frame by removing the screws and remove dust, moisture, and other contaminants with a clean brush, or soft, lint free cloth.
2. Do not use any abrasive materials that could damage the tool.
3. Make certain all pins; pivot points and bearing surfaces are protected with a thin coat of high quality machine oil. Do not oil excessively. The tool was engineered for durability, but like any fine piece of equipment, it needs cleaning and lubrication for a maximum service life of trouble free terminating. Light oil used at the pivot points every 5,000 terminations or 3 months, will significantly enhance the tool life.
4. Wipe excess oil from hand tool, particularly from the terminating area.
5. When tool is not in use, keep the handles closed to prevent objects from becoming lodged in the termination punch and store the tool in a clean, dry area.

Miscrimps or Jams

Should this tool ever become stuck or jammed in a partially closed position, **Do Not force the handles open or closed**. The tool will open easily by pressing the ratchet release lever up. See Figure 5.

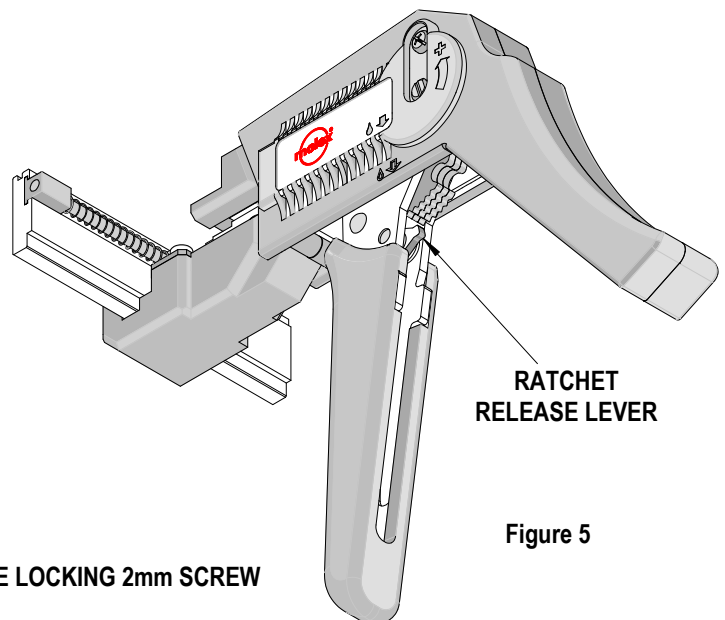

Figure 5

How to Adjust Tool Preload

It may be necessary over the life of the tool to adjust tool handle preload force. Listed below are the steps required to adjust the termination force of the hand tool to obtain proper conditions:

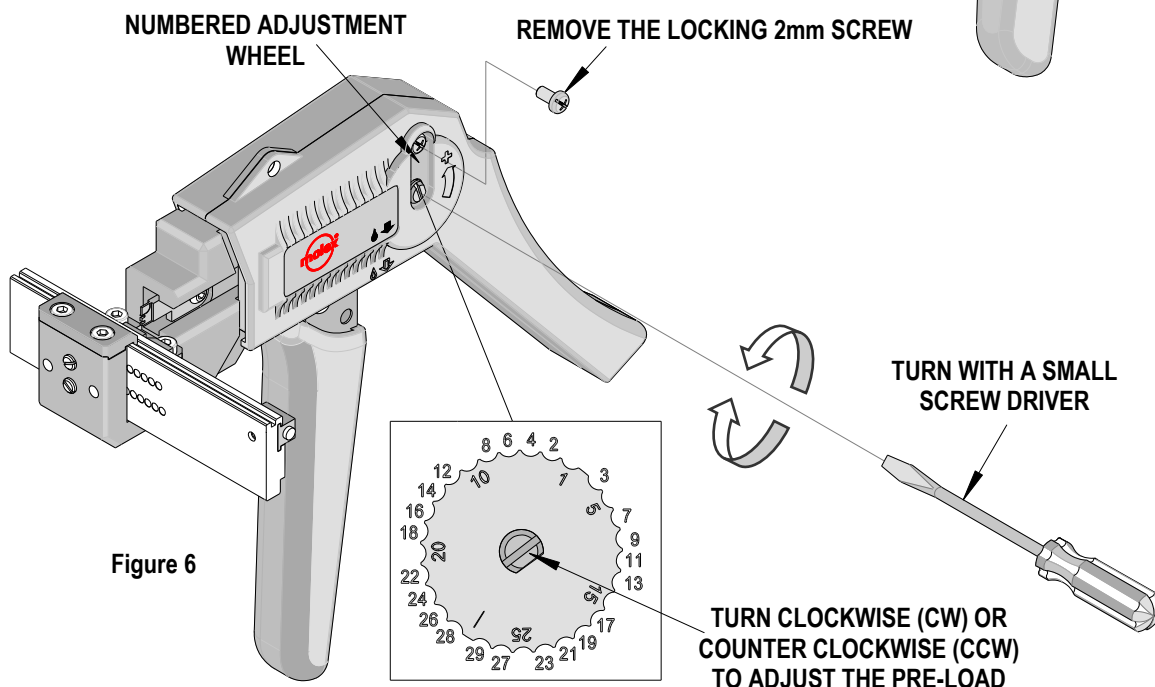

Figure 6

1. Remove the 2mm locking screw from the numbered adjusting wheel using a screw driver. See Figure 6.
2. Using the same screw driver turn the adjustment wheel to the next highest number.
Note: The uneven numbers are in clockwise (CW) direction and the even numbers are counter clockwise (CCW).
3. Example: If the preload is set at number 5, then to increase the preload, turn the adjustment wheel until the 6th position is located over the 2mm locking screw tapped hole. If it is necessary to move to the 7th position, then the adjustment wheel should be turned counter clockwise (CCW) until the 7th position is over the 2mm locking screw tapped hole.
4. Replace the 2mm locking screw, aligning the nearest notch in the setting wheel to locking screw.
5. Check for proper termination depth after the tool handle preload force is adjusted. Repeat these steps until the desired result is obtained.

Warranty

This tool is for terminating individual wires into insulation displacement connectors only. This tool is made of the best quality materials. All vital components are long life tested. All tools are warranted to be free of manufacturing defects for a period of 30 days. Should such a defect occur, we will repair or exchange the tool, free of charge. This repair or exchange will not be applicable to altered, misused, or damaged tools. This tool is designed for hand use only. Any clamping, fixturing, or use of handle extensions voids this warranty.

CAUTION: Molex specifications are valid only when used with Molex connectors and tooling.

CAUTIONS:

1. Manually powered hand tools are intended for low volume, prototyping, or field repair. This tool is **NOT** intended for production use. Repetitive use of this tool should be avoided.
2. Insulated handles are not protection against electrical shock.
3. Wear eye protection at all times.
4. Use only the Molex connectors and wires specified for this tool.

PARTS LIST

Item	Order No	Description	Quantity
1	63819-4800	Hand Crimp Tool	1 (Figure 4)
2	11-11-0320	Spring (Ratchet)	1
3	63600-0479	Spring (Main)	1
4	69008-0972	Adjuster Wheel	1
5	62100-9801	Termination Punch	1

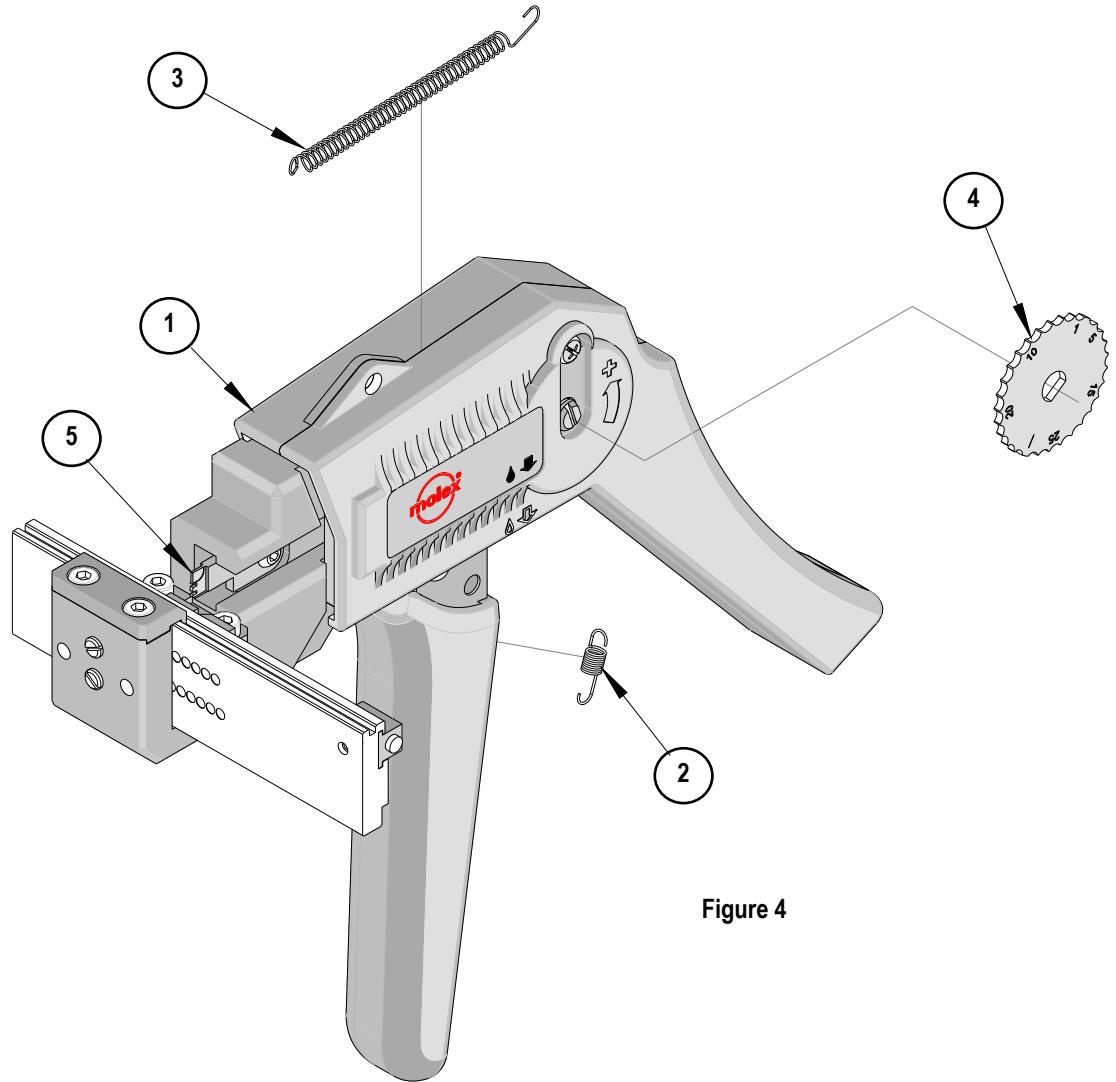

Figure 4

<http://www.molex.com>