

SMD ■ REFLECTOR EAPL4040BA0

PRELIMINARY



Features

- Fluorescence Type
- High Luminous Intensity
- High Efficiency
- Pb-free
- The product itself will remain within RoHS compliant version.

Applications

- OA equipment
- Backlighting of full color LCD
- Automotive equipment
- Replacement of conventional light bulbs and Fluorescent Lamps

Device Selection Guide

| Chip Materials | Emitted Color | Resin Color |
|----------------|---------------|-------------|
| InGaN | Blue | Water Clear |

Absolute Maximum Ratings (Ta=25°C)

| Parameter | Symbol | Rating | Unit |
|--|-----------|---|------|
| Reverse Voltage | V_R | 5 | V |
| Forward Current | I_F | 30 | mA |
| Peak Forward Current (Duty 1/10 @1KHz) | I_{FP} | 100 | mA |
| Power Dissipation | P_d | 110 | mW |
| Electrostatic Discharge(HBM) | ESD | 1000 | V |
| Operating Temperature | T_{opr} | -40 ~ +85 | °C |
| Storage Temperature | T_{stg} | -40 ~ +90 | °C |
| Soldering Temperature | T_{sol} | Reflow Soldering : 260°C for 10 sec. Hand Soldering : 350°C for 3 sec. | |

Electro-Optical Characteristics (Ta=25°C)

| Parameter | Symbol | Min. | Typ. | Max. | Unit | Condition |
|------------------------------|-------------------|-------|------|-------|------|----------------------|
| Luminous Intensity | I _v | 180 | ---- | 450 | mcd | I _F =20mA |
| Viewing Angle | 2θ _{1/2} | ---- | 120 | ---- | deg | |
| Peak Wavelength | λ _p | ---- | 468 | ---- | nm | |
| Dominant Wavelength | λ _d | 464.5 | ---- | 476.5 | nm | |
| Spectrum Radiation Bandwidth | Δλ | ---- | 25 | ---- | nm | |
| Forward Voltage | V _F | 2.75 | ---- | 3.95 | V | |
| Reverse Current | I _R | ---- | ---- | 50 | μA | VR=5V |

Note:

1. Tolerance of Luminous Intensity: ±11%
2. Tolerance of Dominant Wavelength: ±1nm
3. Tolerance of Forward Voltage: ±0.1V

Bin Range of Luminous Intensity

| Bin Code | Min. | Max. | Unit | Conduction |
|----------|------|------|------|----------------------|
| S1 | 180 | 225 | mcd | I _F =20mA |
| S2 | 225 | 285 | | |
| T1 | 285 | 360 | | |
| T2 | 360 | 450 | | |

Note:

Tolerance of Luminous Intensity: ±11%

Bin Range of Dominant Wavelength

| Groups | Bin | Min | Max | Unit | Condition |
|--------|-----|-------|-------|------|----------------------|
| A | A9 | 464.5 | 467.5 | nm | I _F =20mA |
| | A10 | 467.5 | 470.5 | | |
| | A11 | 470.5 | 473.5 | | |
| | A12 | 473.5 | 476.5 | | |

Note:
 Tolerance of Dominant Wavelength: ±1nm

Bin Range of Forward Voltage

| Groups | Bin | Min | Max | Unit | Condition |
|--------|-----|------|------|------|----------------------|
| M | 5 | 2.75 | 3.05 | volt | I _F =20mA |
| | 6 | 3.05 | 3.35 | | |
| | 7 | 3.35 | 3.65 | | |
| | 8 | 3.65 | 3.95 | | |

Note:
 Tolerance of Forward Voltage: ±0.1V

Typical Electro-Optical Characteristics Curves

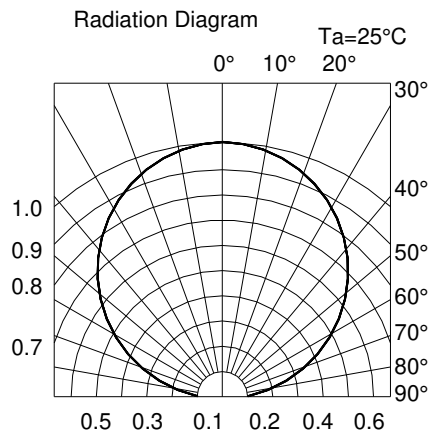
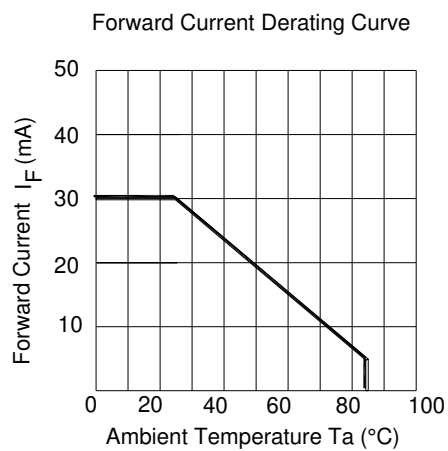
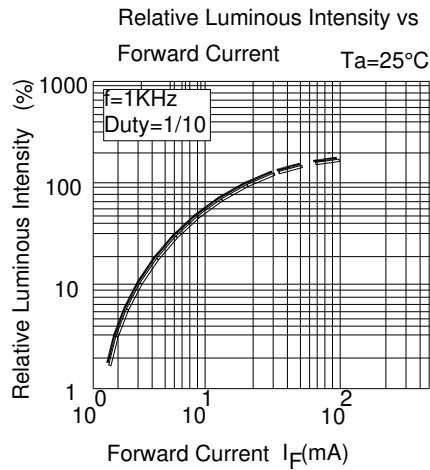
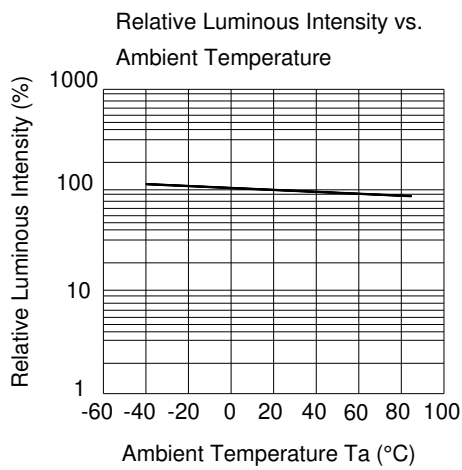
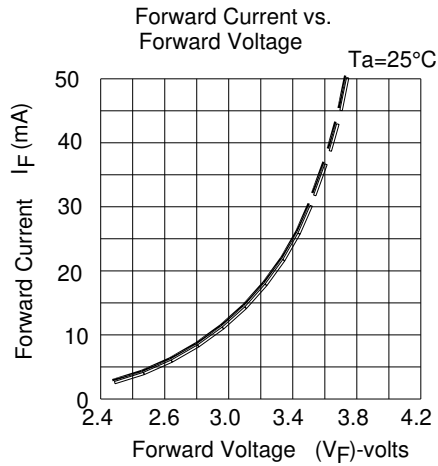
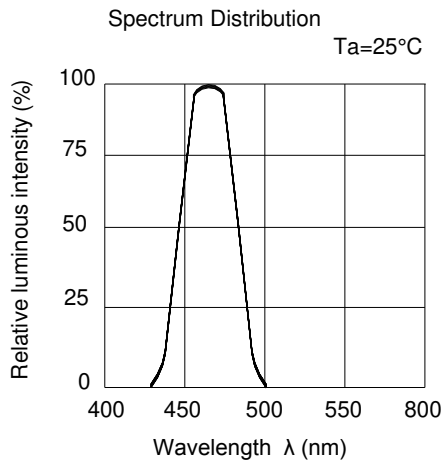

Package Dimension

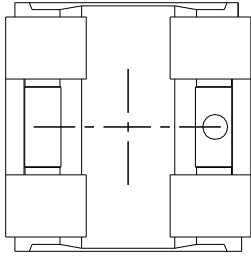

Polarity

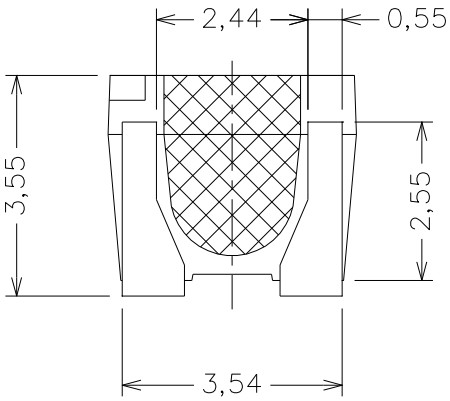
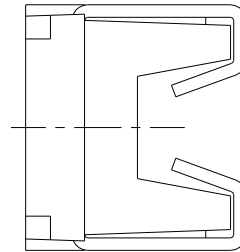
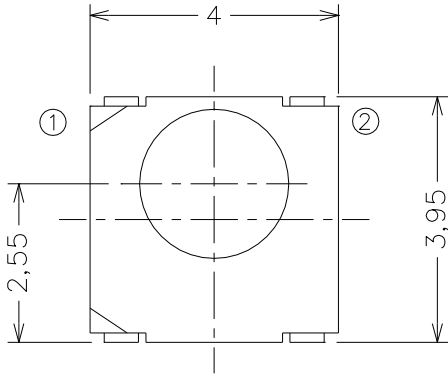

Bot. view

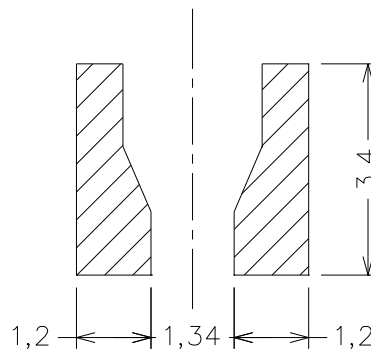

Soldering patterns

Note: Tolerances unless mentioned $\pm 0.1\text{mm}$. Unit = mm

Moisture Resistant Packing Materials

Label Explanation



CAT: Luminous Intensity Rank

HUE: Dom. Wavelength Rank

REF: Forward Voltage Rank

Reel Dimensions

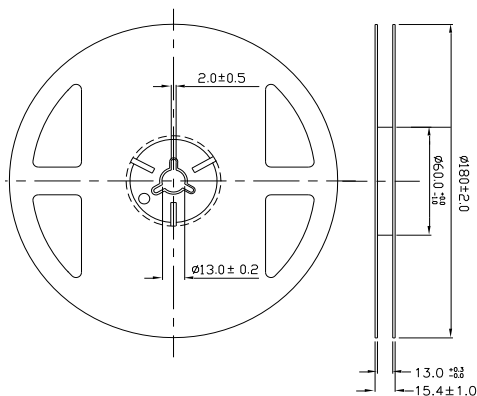

Carrier Tape Dimensions: Loaded Quantity 500 pcs Per Reel

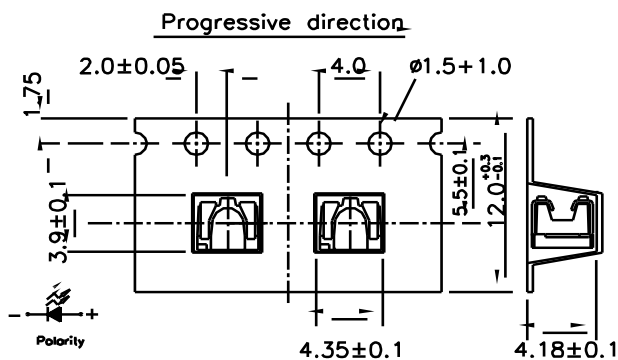

Note: Tolerances unless mentioned ± 0.1 mm. Unit = mm

Moisture Resistant Packing Process

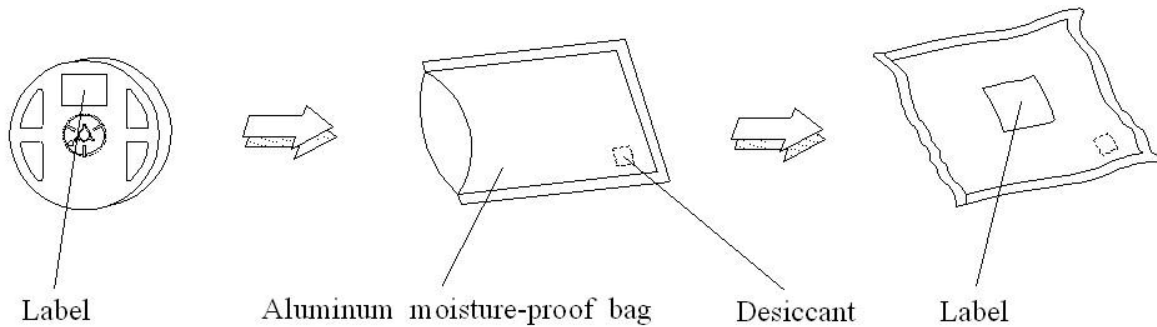

Note: Tolerances unless mentioned $\pm 0.1\text{mm}$. Unit = mm

Reliability Test Items and Conditions

The reliability of products shall be satisfied with items listed below.

Confidence level : 90%

LTPD : 10%

| No. | Items | Test Condition | Test Hours/Cycles | Sample Size | Ac/Re |
|-----|----------------------------------|--|-------------------|-------------|-------|
| 1 | Reflow Soldering | Temp. : $260^{\circ}\text{C} \pm 5^{\circ}\text{C}$ Min. 5sec. | 6 Min. | 22 pcs. | 0/1 |
| 2 | Temperature Cycle | H : $+100^{\circ}\text{C}$ 15min ↓ 5 min L : -40°C 15min | 300 Cycles | 22 pcs. | 0/1 |
| 3 | Thermal Shock | H : $+100^{\circ}\text{C}$ 5min ↓ 10 sec L : -10°C 5min | 300 Cycles | 22 pcs. | 0/1 |
| 4 | High Temperature Storage | Temp. : 100°C | 1000 Hrs. | 22 pcs. | 0/1 |
| 5 | Low Temperature Storage | Temp. : -40°C | 1000 Hrs. | 22 pcs. | 0/1 |
| 6 | DC Operating Life | $I_F = 20 \text{ mA}$ | 1000 Hrs. | 22 pcs. | 0/1 |
| 7 | High Temperature / High Humidity | $85^{\circ}\text{C} / 85\% \text{RH}$ | 1000 Hrs. | 22 pcs. | 0/1 |

Precautions for Use

1. Over-current-proof

Customer must apply resistors for protection, otherwise slight voltage shift will cause big current change (Burn out will happen).

2. Storage

2.1 Do not open moisture proof bag before the products are ready to use.

2.2 Before opening the package: The LEDs should be kept at 30°C or less and 90%RH or less.

2.3 After opening the package: The LED's floor life is 72 hours under 30°C or less and 60% RH or less.

If unused LEDs remain, it should be stored in moisture proof packages.

2.4 If the moisture absorbent material (silica gel) has faded away or the LEDs have exceeded the storage time, baking treatment should be performed using the following conditions.

Baking treatment : 60±5°C for 24 hours.

3. Soldering Condition

3.1 Pb-free solder temperature profile

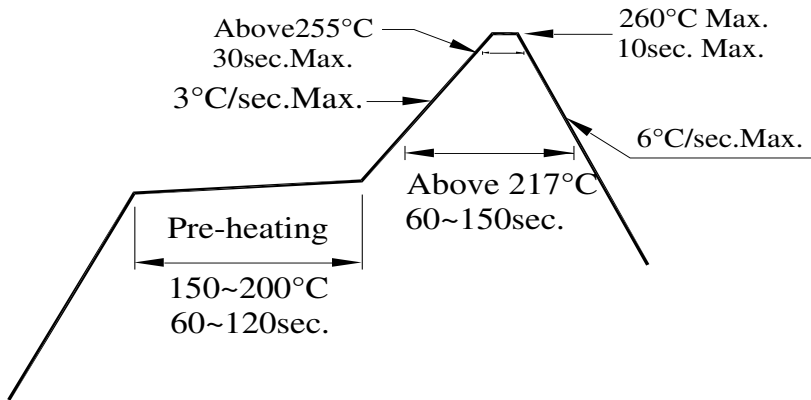

3.2 Reflow soldering should not be done more than two times.

3.3 When soldering, do not put stress on the LEDs during heating.

3.4 After soldering, do not warp the circuit board.

4. Soldering Iron

Each terminal is to go to the tip of soldering iron temperature less than 350°C for 3 seconds within once in less than the soldering iron capacity 25W. Leave two seconds and more intervals, and do soldering of each terminal. Be careful because the damage of the product is often started at the time of the hand solder.

5. Repairing

Repair should not be done after the LEDs have been soldered. When repairing is unavoidable, a double-head soldering iron should be used (as below figure). It should be confirmed beforehand whether the characteristics of the LEDs will or will not be damaged by repairing.

