

LOC	DIST	REVISIONS					
CM	00	P	LTN	DESCRIPTION	DATE	DWN	APVD
		A2		REVISED PER ECO-11-004820	11MAR2011	RK	HMR
		B		REVISED PER ECR-13-008007	17SEP2013	RS	DD

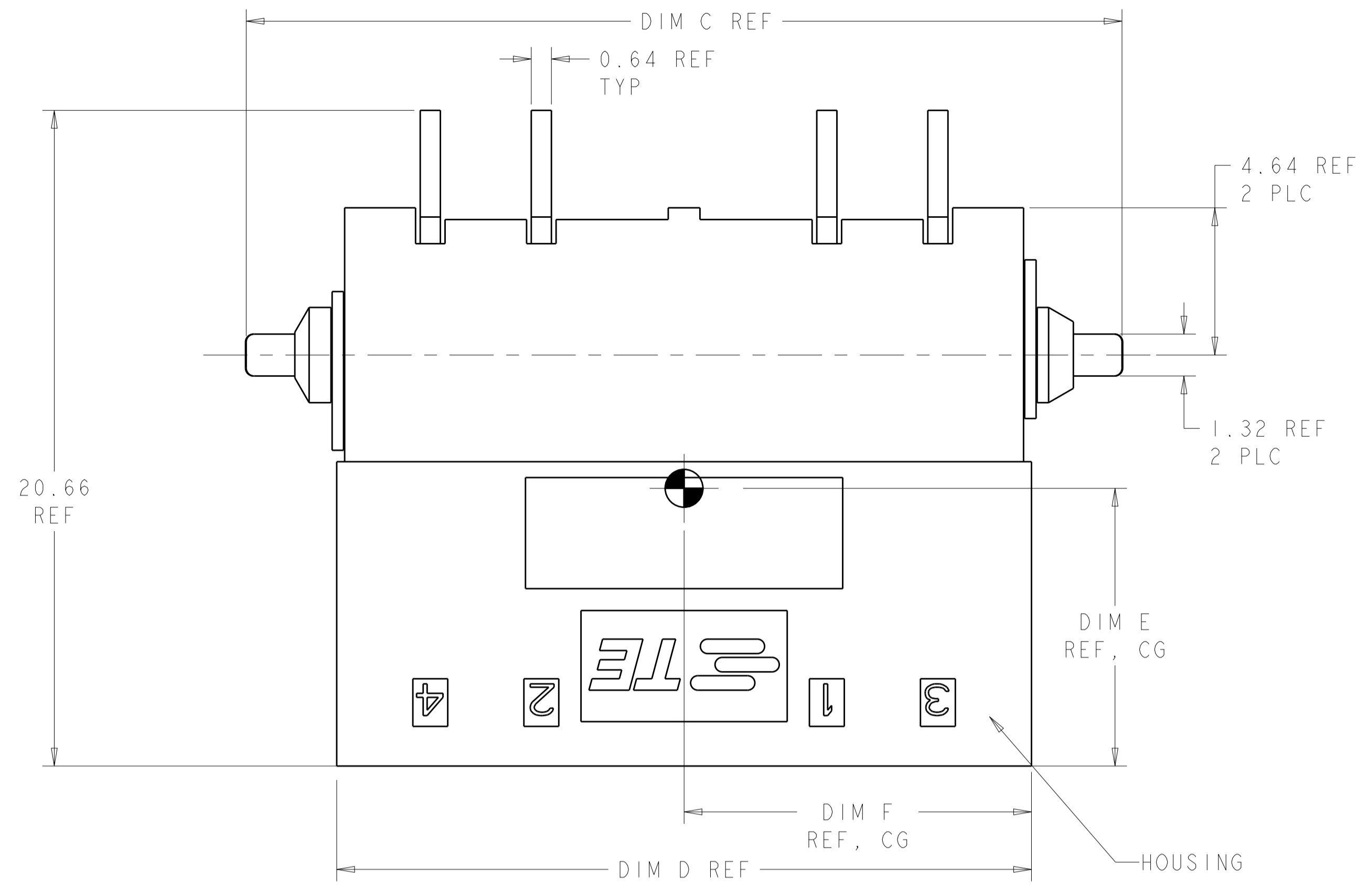

- ⚠ MATERIAL: HOUSING: LCP, COLOR: BLACK.
- CONTACTS: BRASS.  
FINISH: 2.54µm MIN MATTE TIN OVER NICKEL (ENTIRE POST).
- HOLDDOWN: COPPER ALLOY.  
FINISH: 2.54µm MIN MATTE TIN OVER NICKEL.
- 2. THIS PRODUCT HAS NOT COMPLETED VALIDATION TESTING.
- ⚠ RECOMMENDED PC BOARD THICKNESS OF 1.57.
- 4. TAPE AND REEL PACKAGING PER EIA-481 SPEC.
- 5. MUST COMPLY WITH DIRECTIVE 2002/95/EC (ROHS).

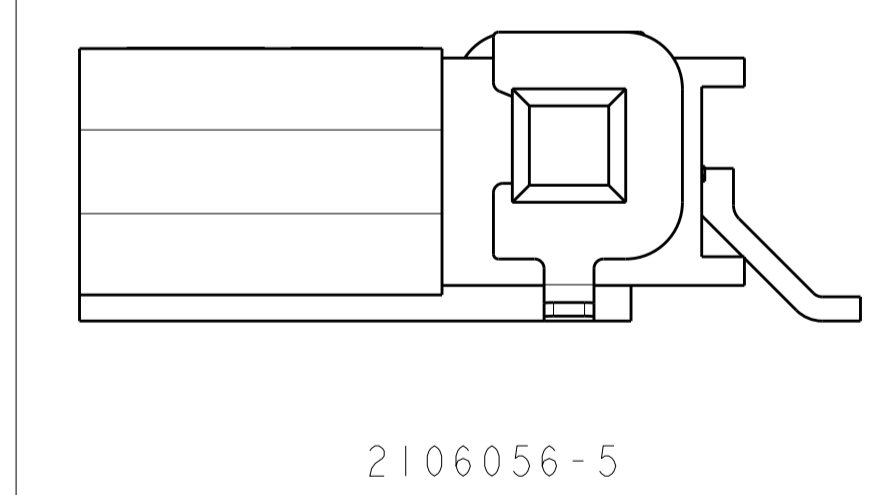
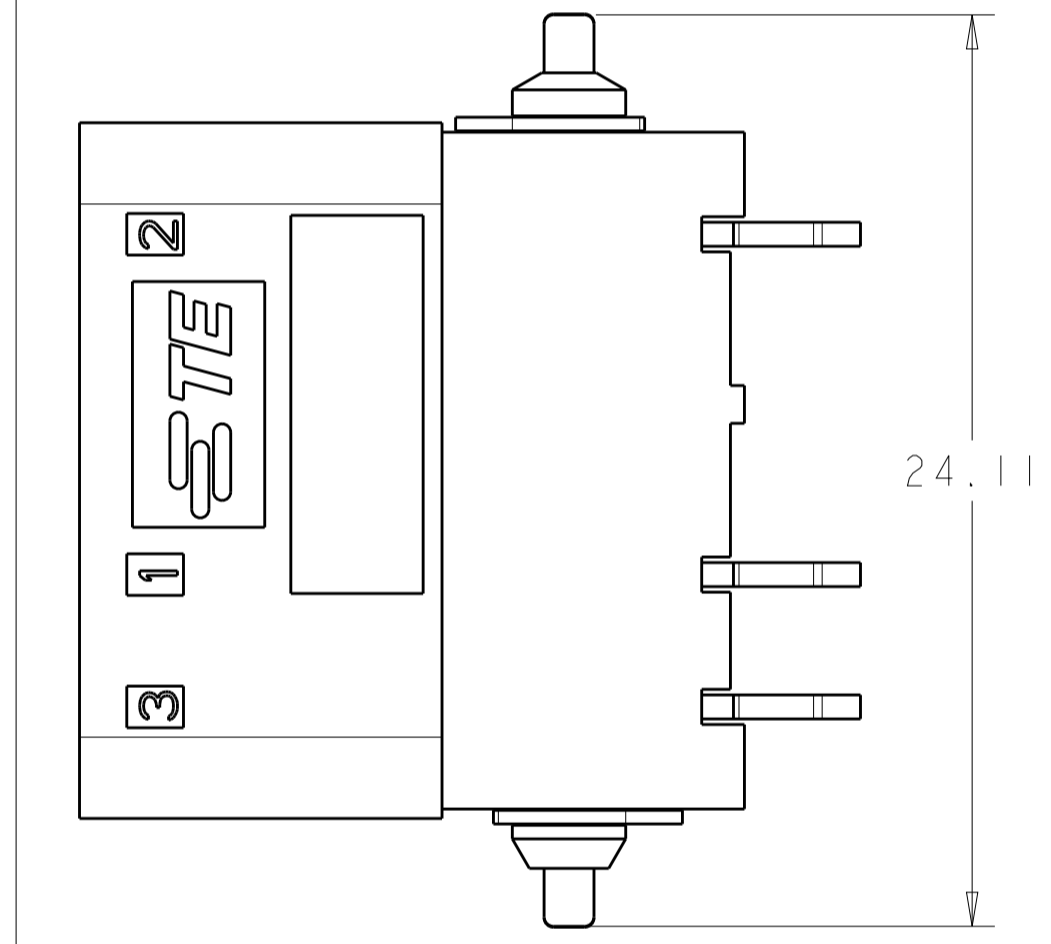
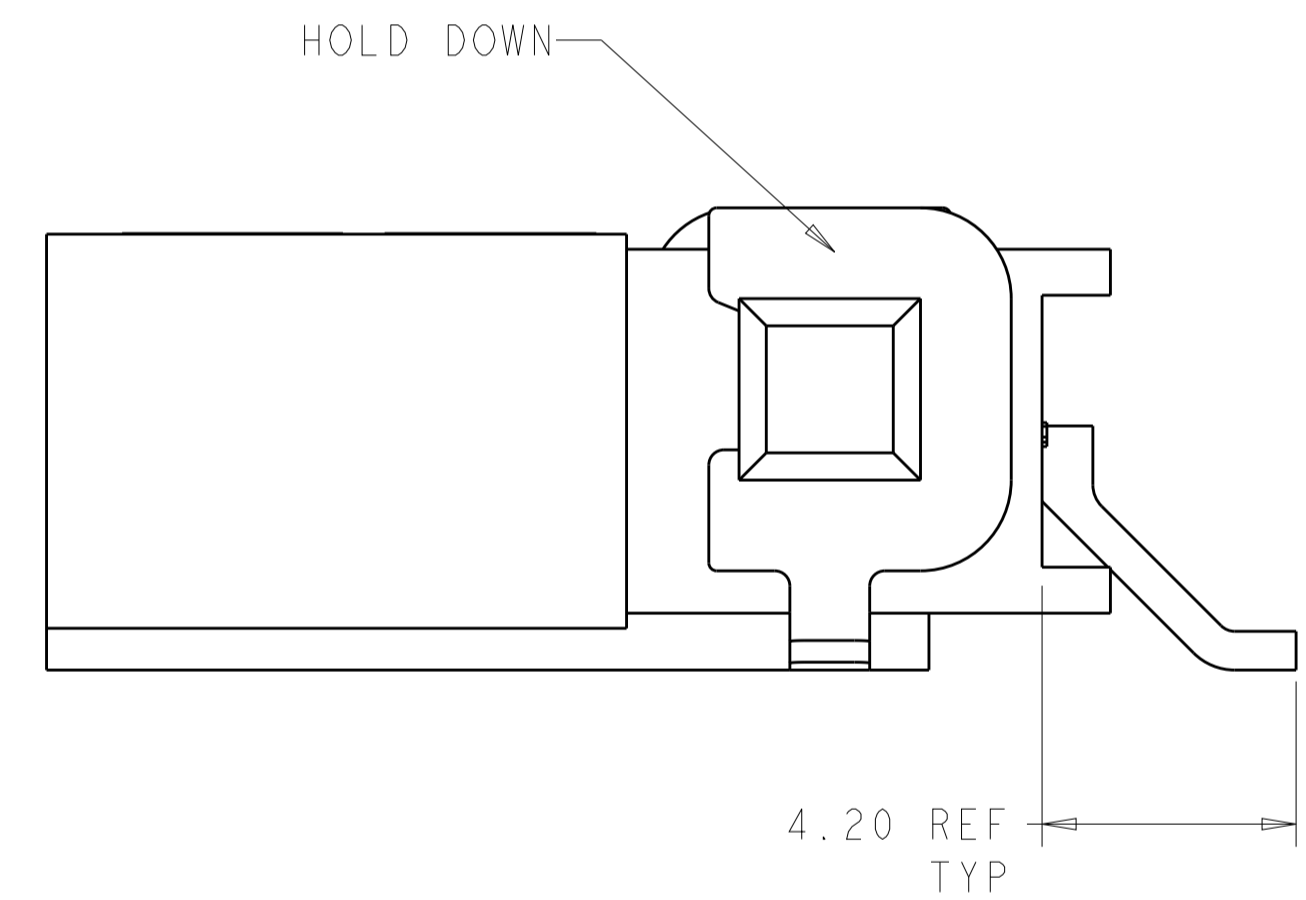
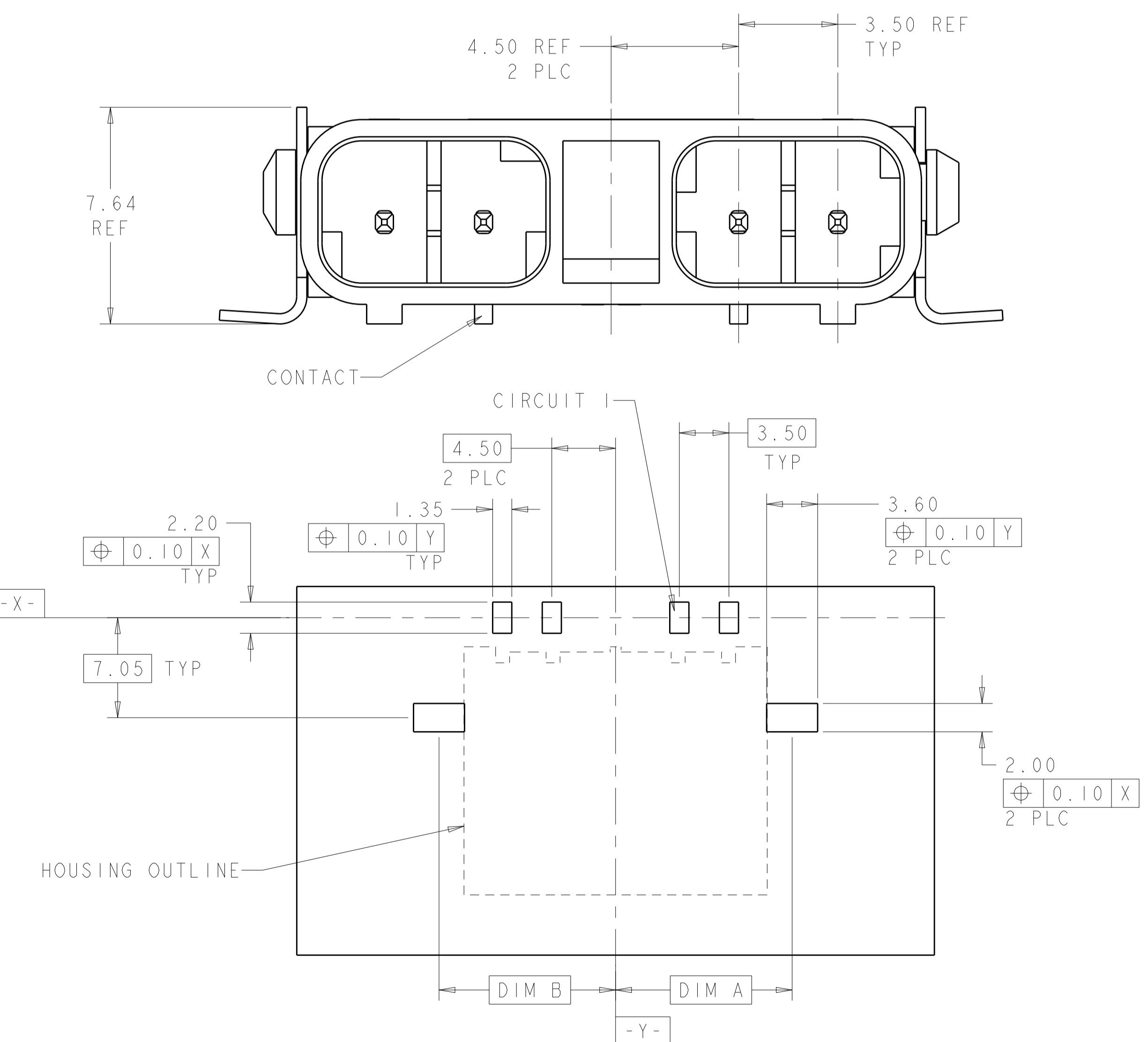
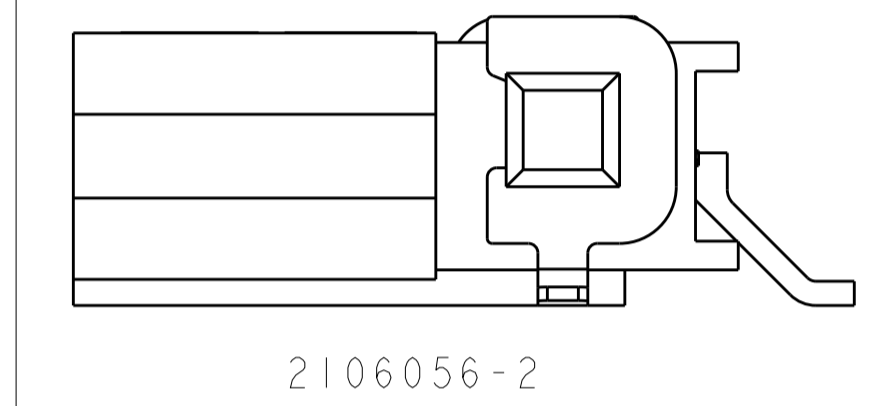
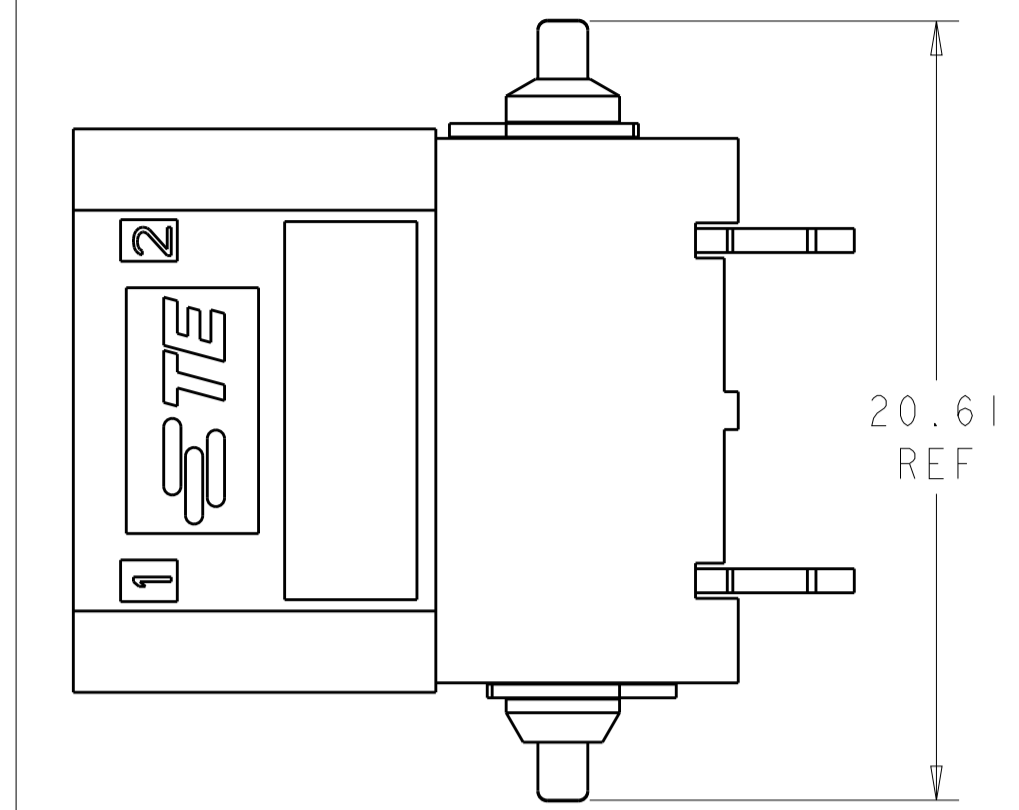

10.94	10.81	21.90	27.61	12.46	12.46	4	2106056-8
9.19	10.68	18.40	24.11	8.96	12.46	3	2106056-5
7.44	10.51	14.90	20.61	8.96	8.96	2	2106056-2
DIM F	DIM E	DIM D	DIM C	DIM B	DIM A	POSN	PART NUMBER

RECOMMENDED PC BOARD PAD LAYOUT, COMPONENT SIDE ⚠  
 DIMENSIONS APPLY TO ALL POSITIONS UNLESS OTHERWISE NOTED

THIS DRAWING IS A CONTROLLED DOCUMENT. DWN: HM VAN SCIO, 26FEB2009  
 CHK: A. BUCHER, 26FEB2009  
 APVD: A. BUCHER, 26FEB2009

**STE** TE Connectivity

ASSEMBLY  
 RIGHT ANGLE SMT HEADER  
 SLIMSEAL SSL CONNECTOR

SIZE: 114-13261  
 WEIGHT: -  
 CUSTOMER DRAWING

SCALE: 4:1 SHEET 1 OF 1 REV B