

UDP C8051F850 MCU CARD USER'S GUIDE FOR C8051F85x/86x MCUs

1. Introduction

The Unified Development Platform (UDP) provides a development and demonstration platform for Silicon Laboratories microcontrollers, short-range wireless devices, and software tools, including the Silicon Laboratories Integrated Development Environment (IDE).

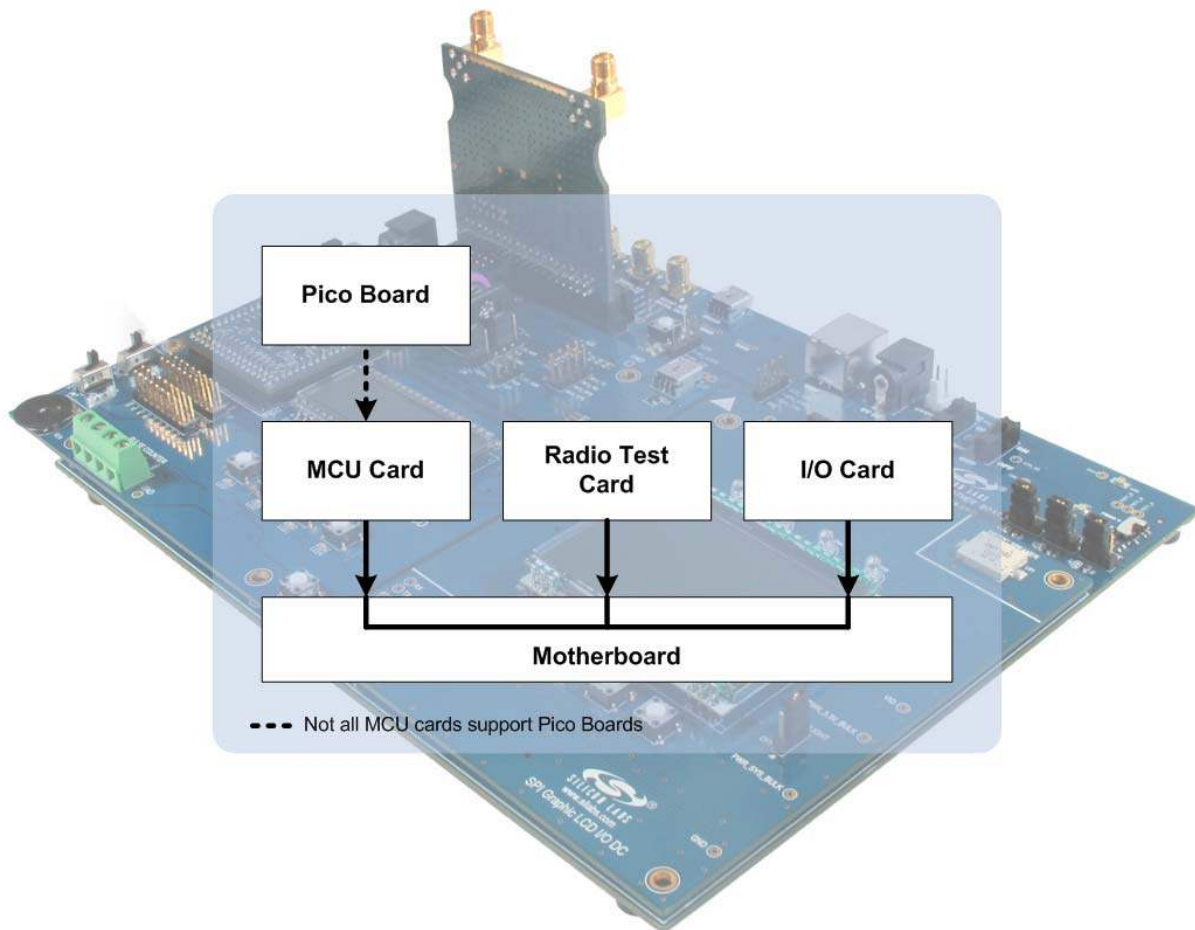

Figure 1. Unified Development Platform Block Diagram

C8051F850-DK-UG

2. Relevant Documents

This document provides a hardware overview for the Unified Development Platform (UDP) system C8051F85x/86x MCU card. Additional information on the UDP system and the Silicon Labs 8-bit MCUs can be found in the documents listed in this section.

2.1. Motherboard User's Guide

The UDP Motherboard User's Guide contains information on the motherboard features and can be found at www.silabs.com/udp.

2.2. Card User's Guides

The UDP MCU, I/O, and radio test card user's guides can be found at www.silabs.com/udp.

2.3. Application Notes

All 8-bit Application Notes can be found at www.silabs.com/8bit-appnotes.

3. Hardware Setup

3.1. Using the MCU Card Alone

Refer to Figure 2 for a diagram of the hardware configuration when using the MCU card without a UDP motherboard.

1. Connect the USB Debug Adapter to the 10-pin debug connector (J23) on the MCU card using the 10-pin ribbon cable.
2. Connect the USB Debug Adapter to a USB Port on the PC.
3. Move the SW1 VDD Select switch to the top **+3.3V_VREG** position.
4. Verify that the JP2 Imeasure jumper is populated.
5. Power the MCU card through the power connector (J6) using the supplied 9 V ac/dc adapter.

Notes:

- Use the **Reset** button in the IDE to reset the target when connected using a USB Debug Adapter.
- Remove power from the MCU card and the USB Debug Adapter before connecting or disconnecting the ribbon cable from the MCU card. Connecting or disconnecting the cable when the devices have power can damage the device and/or the USB Debug Adapter.

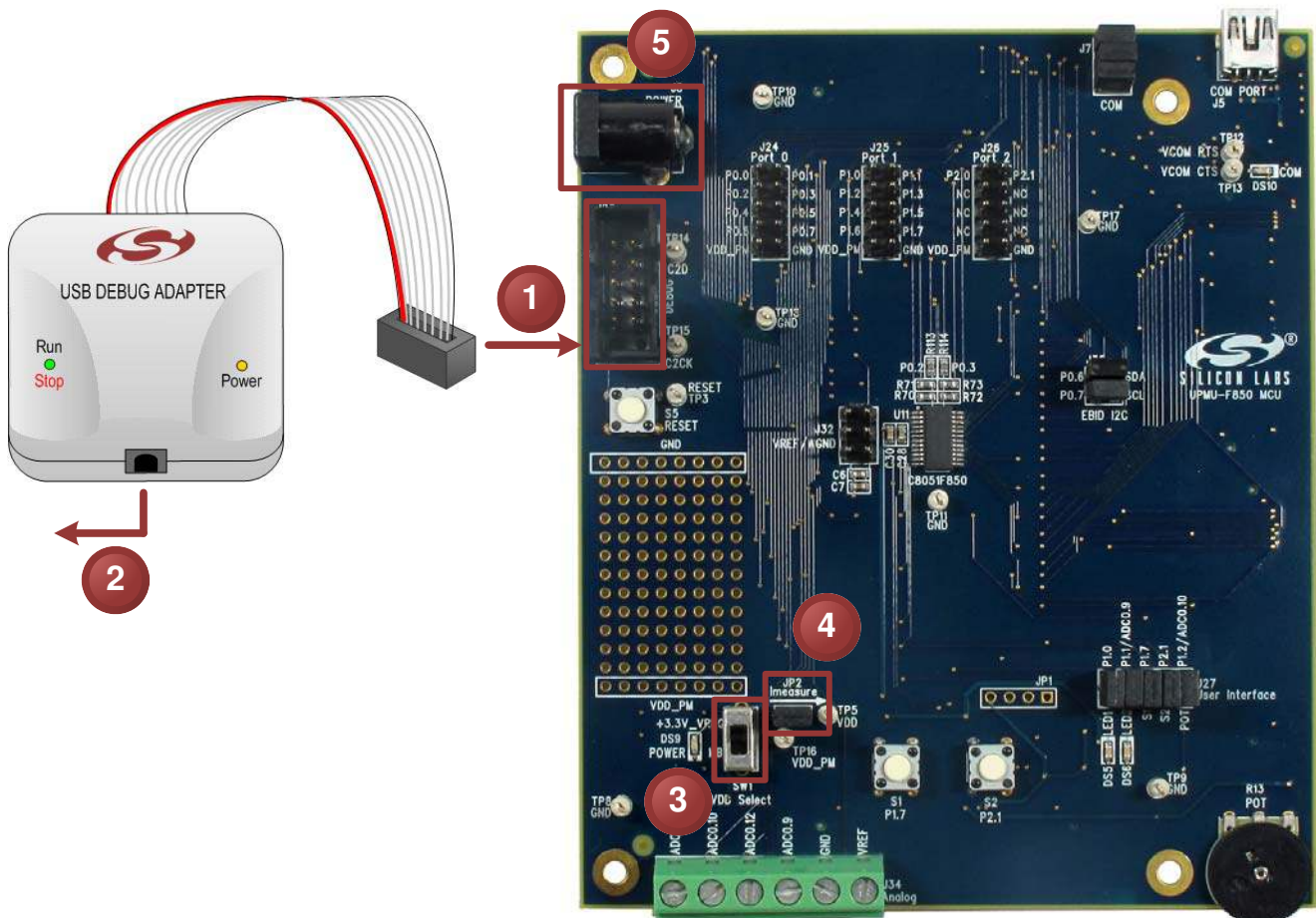

Figure 2. Hardware Setup Using the MCU Card Alone

3.2. Using the MCU Card with the UDP Motherboard

Refer to Figure 3 for a diagram of the hardware configuration when using the MCU card with a UDP motherboard.

1. Connect the MCU card to the UDP motherboard slot.
2. (Optional) Connect an I/O card to the UDP motherboard slot.
3. (Optional) Connect a radio test card to the radio test card slot in the UDP motherboard.
4. (Optional) Connect an EZLink card to the EZLink card slot in the UDP motherboard.
5. Connect the USB Debug Adapter to the 10-pin debug connector (J23) on the MCU card using the 10-pin ribbon cable.
6. Connect the USB Debug Adapter to a USB Port on the PC.
7. Move the SW1 VDD Select switch to the lower **MB** position.
8. Verify that the JP2 Imeasure jumper is populated.
9. Connect the ac/dc power adapter to power jack J20 on the UDP motherboard. The board can also be powered from the J16 USB, J1 mini USB connectors, or J11 battery connector socket.
10. Move the S3 power switch on the UDP motherboard to the ON position.
11. Update the motherboard firmware as described in Section 3.3.

Notes:

- Use the **Reset** button in the IDE to reset the target when connected using a USB Debug Adapter.
- Remove power from the target board and the USB Debug Adapter before connecting or disconnecting the ribbon cable from the target board. Connecting or disconnecting the cable when the devices have power can damage the device and/or the USB Debug Adapter.
- The MCU card can be used alone without the motherboard. However, the motherboard must be powered if an MCU card is connected.

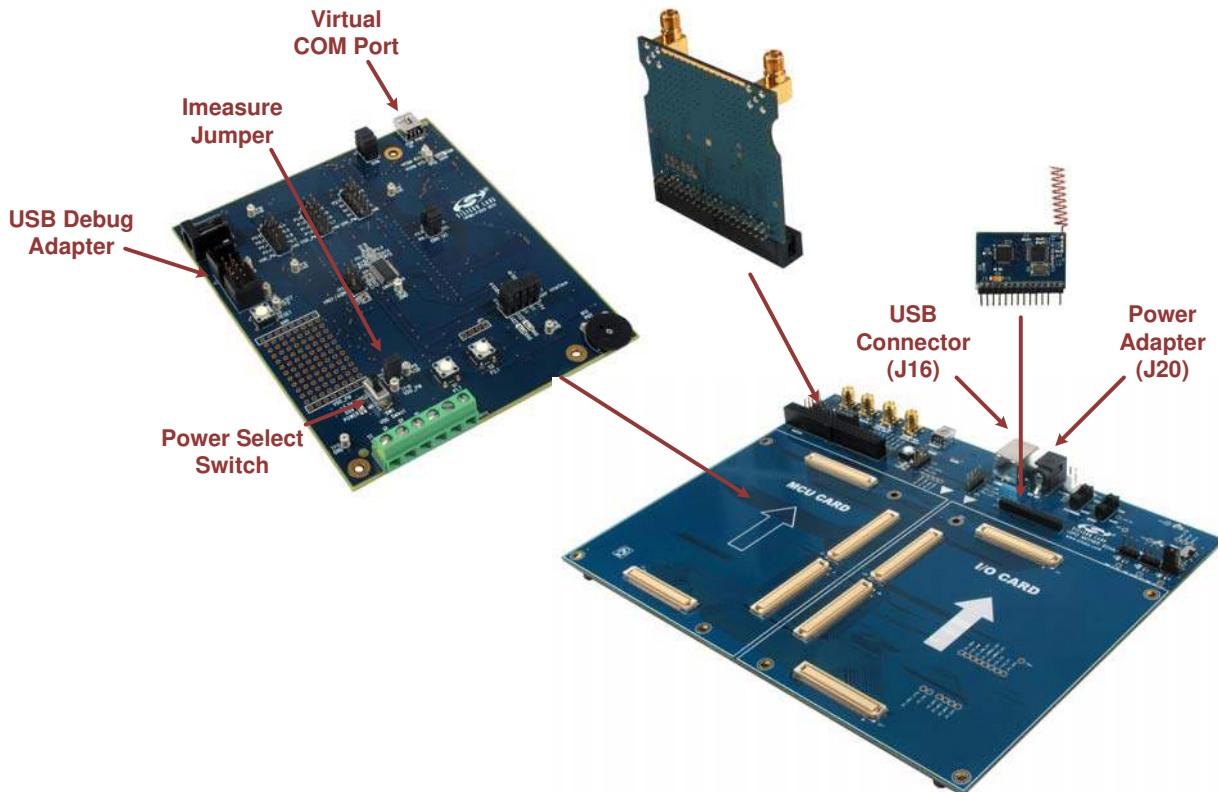

Figure 3. Hardware Setup Using the Unified Development Platform

3.3. Updating the UDP Motherboard Firmware

To ensure the UDP Motherboard supports the C8051F85x/86x MCU card, run the UDP Motherboard Firmware Update Utility shown in Figure 4. This utility can be downloaded from www.silabs.com/udp.

1. Connect the UDP motherboard to a PC using a regular USB cable connected to the UDS connector (J16).
2. Run the utility.
3. Select the desired motherboard if more than one is connected to the PC.
4. Press the **Update Selected Device** button.



Figure 4. UDP Motherboard Firmware Update Utility

4. Software Setup

Simplicity Studio greatly reduces development time and complexity with Silicon Labs EFM32 and 8051 MCU products by providing a high-powered IDE, tools for hardware configuration, and links to helpful resources, all in one place.

Once Simplicity Studio is installed, the application itself can be used to install additional software and documentation components to aid in the development and evaluation process.

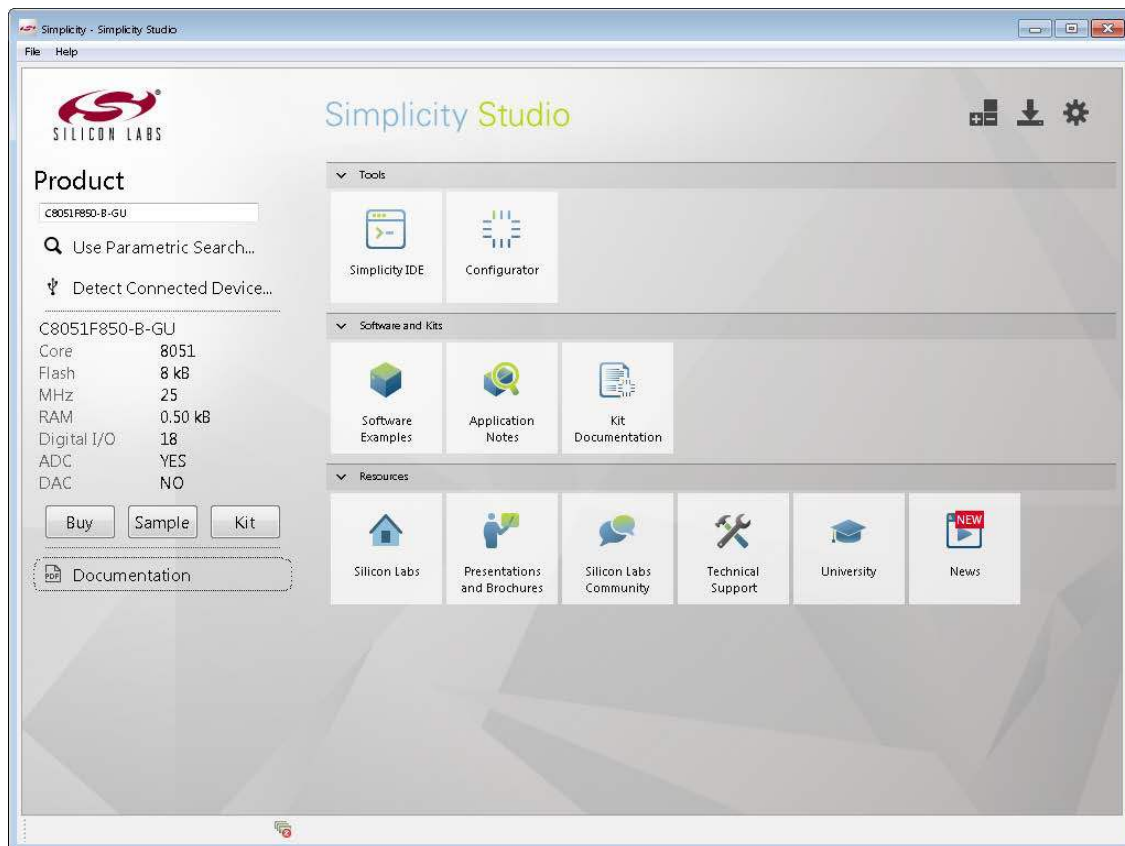

Figure 5. Simplicity Studio

The following Simplicity Studio components are required for the C8051F850 Development Kit:

- 8051 Products Part Support
- Simplicity Developer Platform

Download and install Simplicity Studio from www.silabs.com/8bit-software or www.silabs.com/simplicity-studio. Once installed, run Simplicity Studio by selecting **Start**→**Silicon Labs**→**Simplicity Studio**→**Simplicity Studio** from the start menu or clicking the **Simplicity Studio** shortcut on the desktop. Follow the instructions to install the software and click **Simplicity IDE** to launch the IDE.

The first time the project creation wizard runs, the **Setup Environment** wizard will guide the user through the process of configuring the build tools and SDK selection.

In the **Part Selection** step of the wizard, select from the list of installed parts only the parts to use during development. Choosing parts and families in this step affects the displayed or filtered parts in the later device selection menus. Choose the C8051F85x family by checking the **C8051F85x/86x** check box. Modify the part selection at any time by accessing the **Part Management** dialog from the **Window**→**Preferences**→**Simplicity Studio**→**Part Management** menu item.

Simplicity Studio can detect if certain toolchains are not activated. If the **Licensing Helper** is displayed after completing the **Setup Environment** wizard, follow the instructions to activate the toolchain.

4.1. Running Blinky

Each project has its own source files, target configuration, SDK configuration, and build configurations such as the **Debug** and **Release** build configurations. The IDE can be used to manage multiple projects in a collection called a workspace. Workspace settings are applied globally to all projects within the workspace. This can include settings such as key bindings, window preferences, and code style and formatting options. Project actions, such as build and debug are context sensitive. For example, the user must select a project in the **Project Explorer** view in order to build that project.

To create a project based on the Blinky example:

1. Click the **Simplicity IDE** tile from the Simplicity Studio home screen.
2. Click the **Create new project** link from the welcome screen or go to **File**→**New**→**Silicon Labs MCU Project**.
3. In the **Kit** drop-down, select **C8051F850 Development Kit**, in the **Part** drop-down, select **C8051F850**, and in the **SDK** drop-down, select the desired SDK. Click **Next**.
4. Select **Example** and click **Next**.
5. Under **C8051F850 Development Kit** in the **Blinky** folder, select **F85x-86x Blinky** and click **Finish**.
6. Click on the project in the **Project Explorer** and click **Build**, the hammer icon in the top bar. Alternatively, go to **Project**→**Build Project**.
7. Click **Debug** to download the project to the hardware and start a debug session.
8. Press the **Resume** button to start the code running. The LED should blink.



9. Press the **Suspend** button to stop the code.



10. Press the **Reset the device** button to reset the target MCU.



11. Press the **Disconnect** button to return to the development perspective.



4.2. Simplicity Studio Help

Simplicity Studio includes detailed help information and device documentation within the tool. The help contains descriptions for each dialog window. To view the documentation for a dialog, click the question mark icon in the window:



This will open a pane specific to the dialog with additional details.

The documentation within the tool can also be viewed by going to **Help**→**Help Contents** or **Help**→**Search**.

4.3. Simplicity Configurator

The Simplicity Configurator is a configuration and code generation tool. This utility helps accelerate development by automatically generating initialization source code to configure and enable the on-chip resources needed by most design projects. In just a few steps, the wizard creates complete startup code for a specific Silicon Labs MCU.

To create a new Simplicity Configurator project:

1. Click the **Create new project** link from the welcome screen or go to **File→New→Silicon Labs MCU Project**.
2. In the **Kit** drop-down, select **C8051F850 Development Kit** or **None**, in the **Part** drop-down, select **C8051F850**, and in the **SDK** drop-down, select the desired SDK. Click **Next**.
3. Select **Simplicity Configurator Program** and click **Next**.
4. Fill in the **Project name** and select the desired device. The **C8051F850-C-GU-QSOP** device is on the C8051F850 Target Board. Click **Finish**.

The Simplicity Configurator project displays properties for each peripheral. To configure a peripheral, click on the **DefaultMode Peripherals** tab at the bottom and click on a peripheral. Checking the box for a peripheral will add it to code generation. Once a peripheral is selected, configure the registers using the **Properties** view. Select a new value for a property with either an input box or a drop-down menu and press **Enter** to set it.

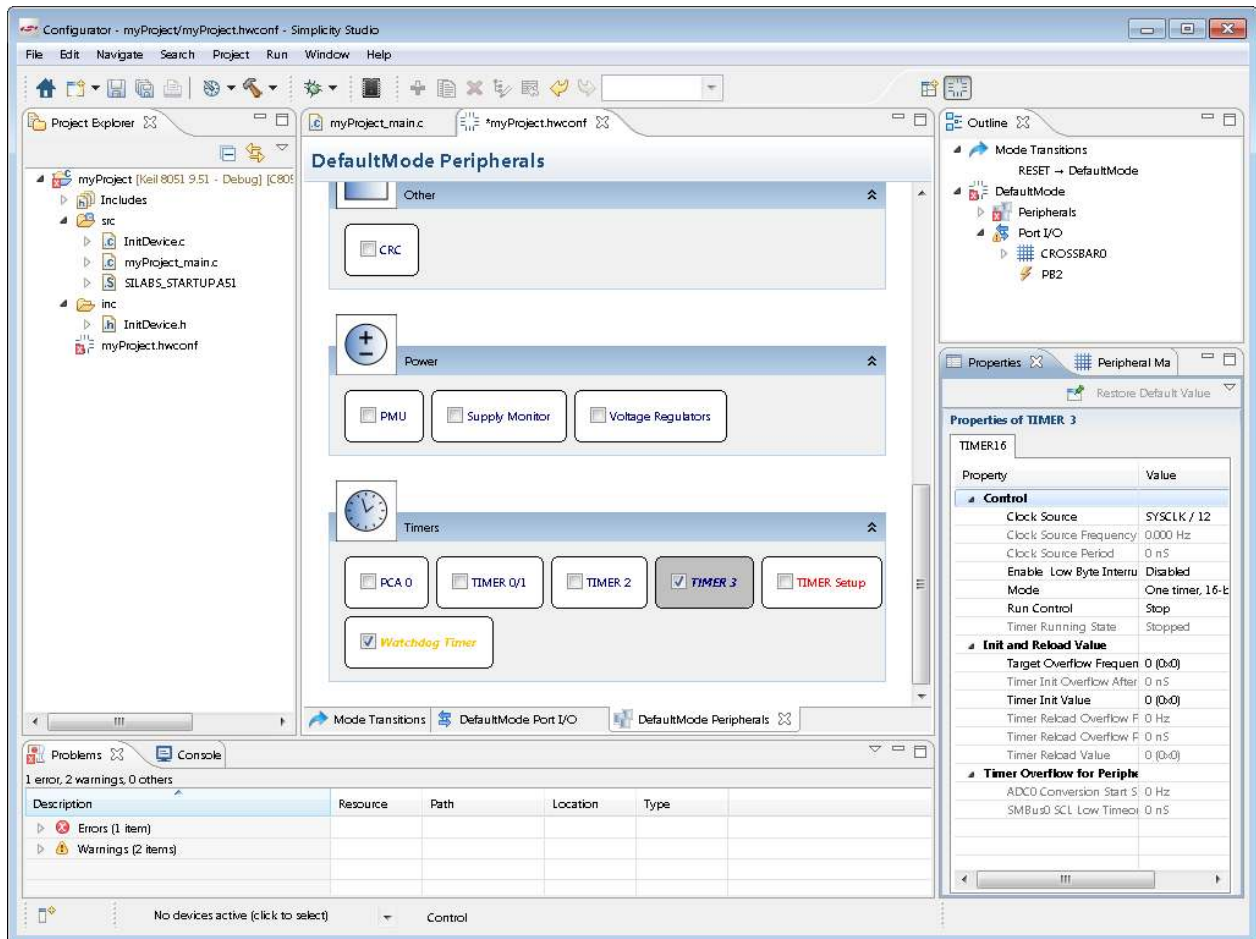

Figure 6. Simplicity Configurator – Configuring Peripheral Properties

To configure pins, click on the **DefaultMode Port I/O** tab at the bottom of main window. Clicking on a pin brings up a property window for the pin. Clicking anywhere else in the main window opens a property window for the crossbar. Select multiple pins with **Ctrl + left click** or mouse dragging over the desired set of pins. The package diagram displays the configured peripherals on the pins, including non-crossbar signals (i.e. ADC inputs).

Code generation updates every time the configuration project saves. After configuring the device, add any non-initialization code, build, and debug the same as with any other project.

More information on Simplicity Configurator can be found in **AN0823: Simplicity Configurator User's Guide** and **AN0821: Simplicity Studio C8051F85x Walkthrough**. Application notes can be found on www.silabs.com/8bit-appnotes.

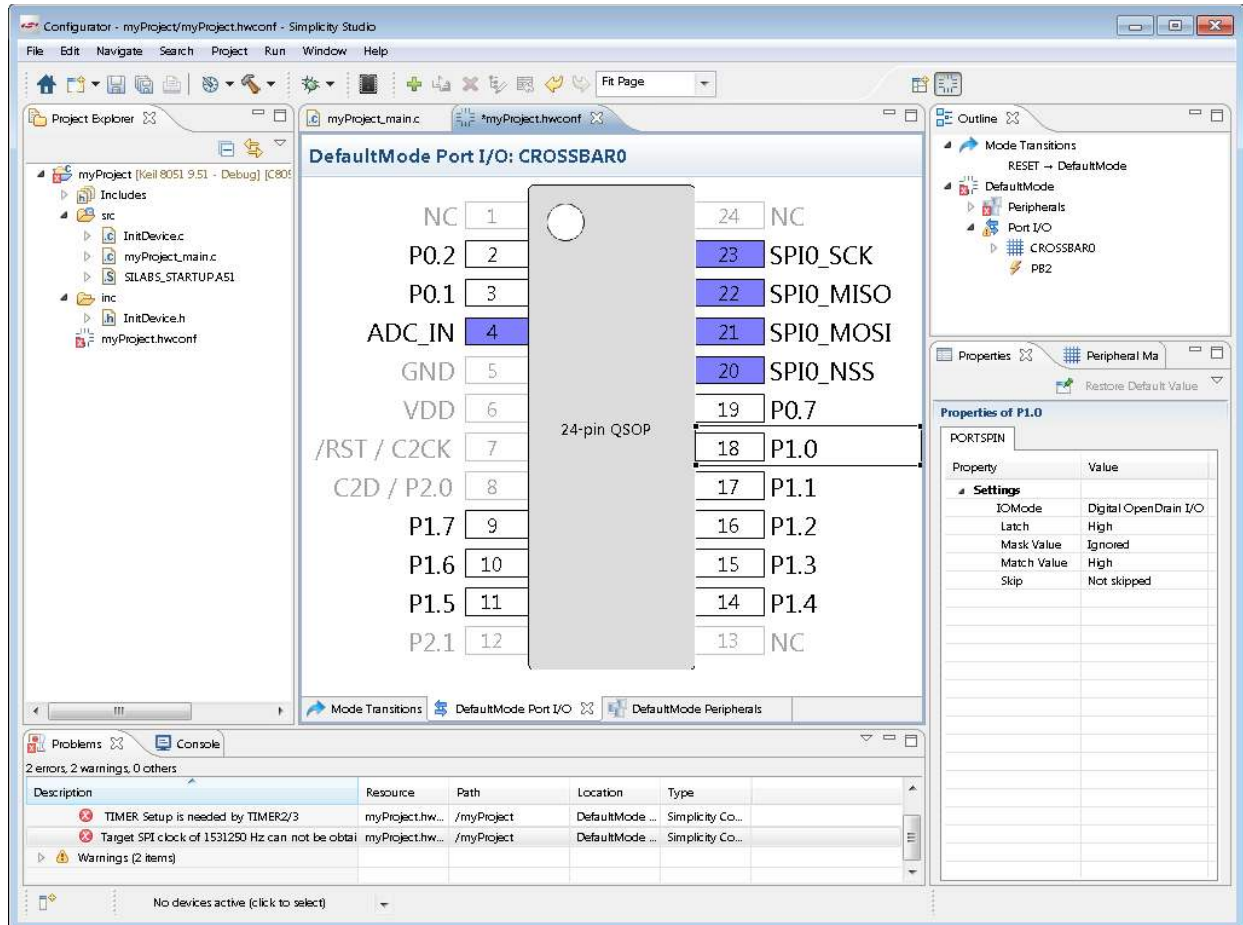

Figure 7. Simplicity Configurator – Configuring Port I/O

4.4. Legacy 8-bit IDE

Note: Using the Simplicity Studio tools with the C8051F850 Development Kit is recommended. See section 4. "Software Setup," on page 6 for more information.

Download the 8-bit software from the website (www.silabs.com/8bit-software) or use the provided installer on the CD-ROM to install the software tools for the C8051F85x/86x devices. After installation, examples can be found in ...\\Examples\\C8051F85x_86x in the installation directory. At a minimum, the C8051F850 DK requires:

- **Silicon Labs IDE**—Software enabling initial evaluation, development, and debugging.
- **Configuration Wizard 2**—Initialization code generation software for the C8051F85x/86x devices.
- **Keil C51 Tools**—Keil 8051 Compiler/Assembler/Linker toolchain.
- **CP210x Drivers**—Virtual COM Port (VCP) drivers for the CP210x COM interface. More information on this installation process can be found in Section 4.5.

Other software available includes:

- **Keil μ Vision Driver**—Driver for the Keil μ Vision IDE that enables development and debugging on C8051Fxxx MCUs.
- **Flash Programming Utilities** and **MCU Production Programmer**—Programming utilities for the production line. More information on the available programming options can be found on the website: <http://www.silabs.com/products/mcu/Pages/ProgrammingOptions.aspx>.
- **ToolStick Development Tools**—Software and examples for the ToolStick development platform. More information on this platform can be found at www.silabs.com/toolstick.

The development kit includes the latest version of the C51 Keil 8051 toolset. This toolset is initially limited to a code size of 2 kB and programs start at code address 0x0800. After registration, the code size limit is removed entirely and programs will start at code address 0x0000.

To register the Keil toolset:

1. Find the **Product Serial Number** printed on the CD-ROM. If you no longer have this serial number, register on the Silicon Labs website (www.silabs.com/8bit-software) to obtain the serial number.
2. Open the Keil μ Vision4 IDE from the installation directory with administrative privileges.
3. Select **File**→**License Management** to open the License Management window.

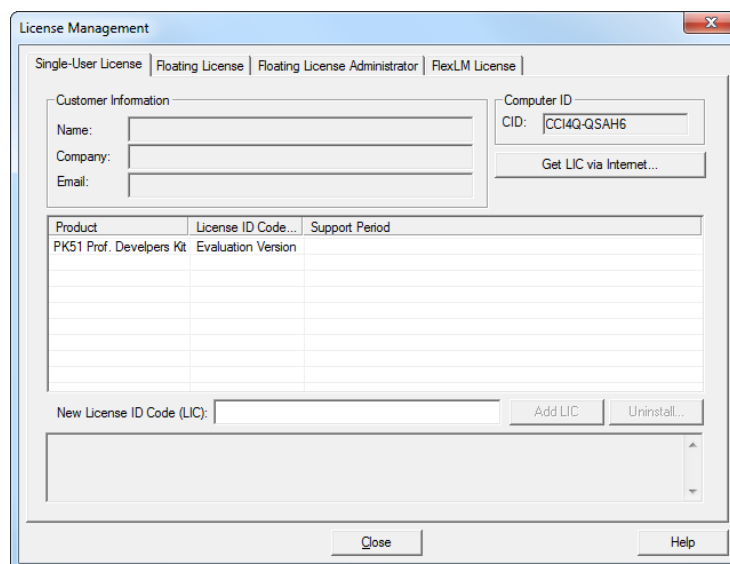

Figure 8. Keil μ Vision4 IDE License Management Window

4. Click on the **Get LIC via Internet...** button to open the Obtaining a License IDE Code (LIC) window.
5. Press **OK** to open a browser window to the Keil website. If the window doesn't open, navigate to

www.keil.com/license/install.htm.

6. Enter the Silicon Labs **Product Serial Number** printed on the CD-ROM, along with any additional required information.
7. Once the form is complete, click the **Submit** button. An email will be sent to the provided email address with the license activation code.
8. Copy the License ID Code (LIC) from the email.
9. Paste the LIC into the **New License ID Code (LIC)** text box at the bottom of the License Management window in μ Vision4.
10. Press the **Add LIC** button. The window should now list the **PK51 Prof. Developers Kit for Silabs** as a licensed product.
11. Click the **Close** button.

4.5. CP210x USB to UART VCP Driver Installation

The MCU Card includes a Silicon Labs CP210x USB-to-UART Bridge Controller. Device drivers for the CP210x need to be installed before the PC software can communicate with the MCU through the UART interface. Use the drivers included CD-ROM or download the latest drivers from the website (www.silabs.com/interface-software).

1. If using the CD-ROM, the **CP210x Drivers** option will launch the appropriate driver installer. If downloading the driver package from the website, unzip the files to a location and run the appropriate installer for the system (x86 or x64).
2. Accept the license agreement and follow the steps to install the driver on the system. The installer will let you know when your system is up to date. The driver files included in this installation have been certified by Microsoft.
3. To complete the installation process, connect the included USB cable between the host computer and the **COM PORT** USB connector (J5) on the MCU Card. Windows will automatically finish the driver installation. Information windows will pop up from the taskbar to show the installation progress.
 - If needed, the driver files can be uninstalled by selecting **Windows Driver Package—Silicon Laboratories...** option in the **Programs and Features** window.

C8051F850-DK-UG

5. C8051F85x/86x MCU Card Overview

The C8051F850 MCU card enables application development on the C8051F85x/86x MCU device family. The card connects to the MCU card expansion slot on the UDP motherboard and provides complete access to the MCU resources. Each expansion board has a unique ID that can be read out of an EEPROM or MCU on the board, which enables software tools to recognize the connected hardware and automatically select the appropriate firmware image. The target MCU card can also be detached from the UDP and used alone as a development or demonstration tool.

Figure 9 and Figure 10 highlight the C8051F850 MCU card features.

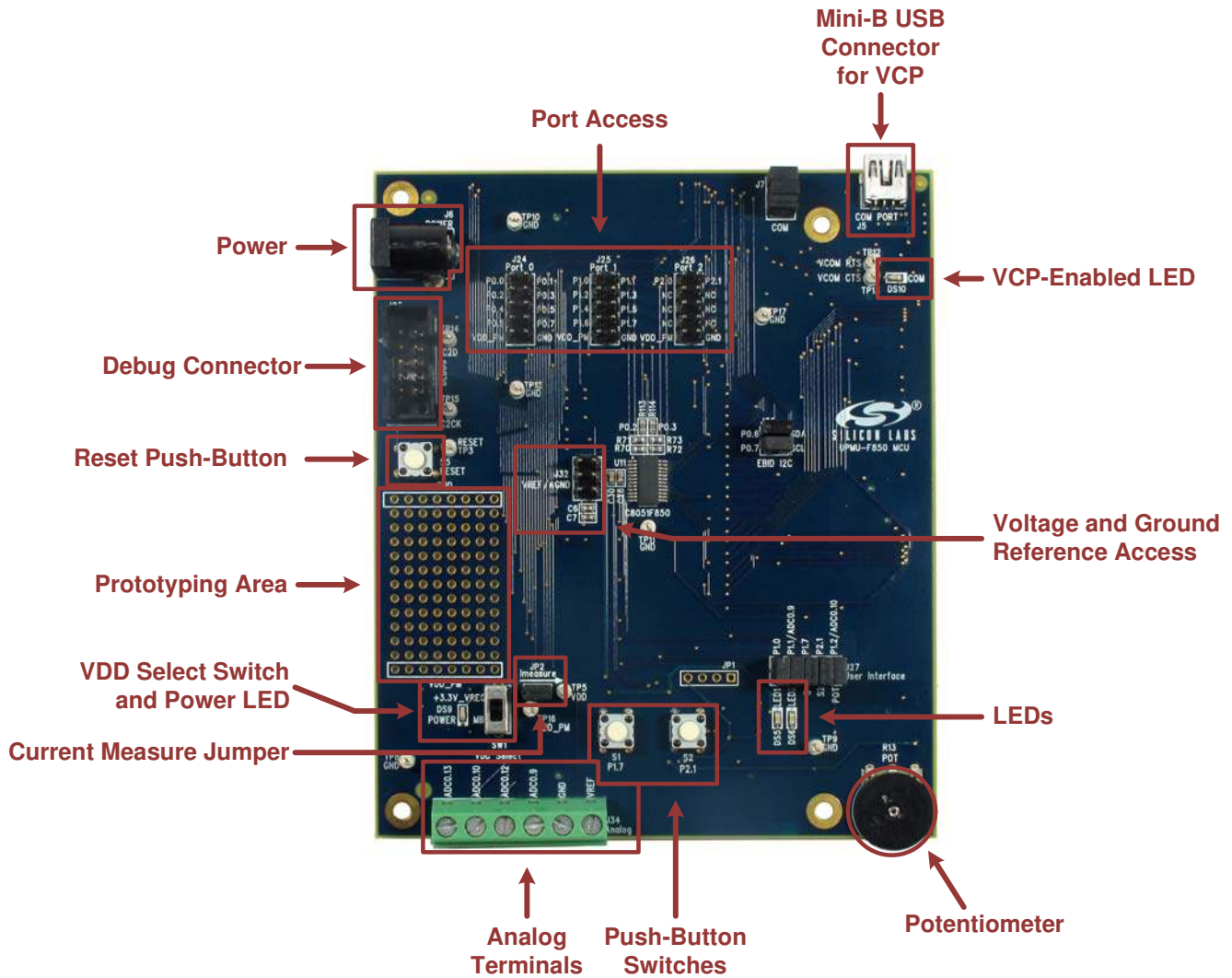

Figure 9. C8051F850 MCU Card Features—Front

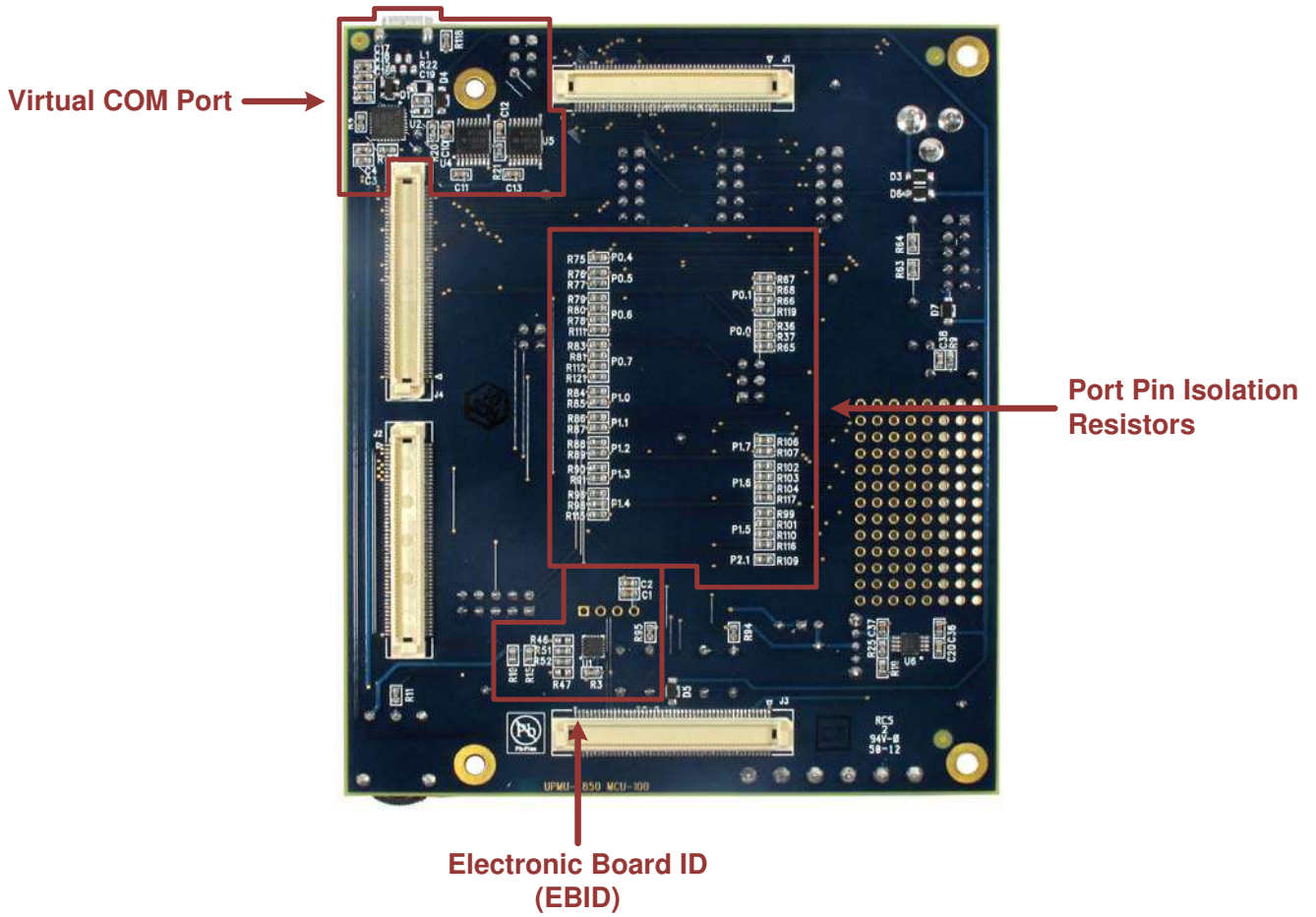

Figure 10. C8051F850 MCU Card Features—Back

C8051F850-DK-UG

5.1. Push-Button Switches and LEDs (S1-2, DS5-6)

The UDP C8051F850 MCU Card has two push-button switches and two LEDs. The two LEDs connect to P1.0 and P1.1, and the two switches connect to P1.7 and P2.1. The switches are normally open and pull the pin voltage to ground when pressed. The LEDs connect to VDD through a current-limiting resistor and turn on when the corresponding port pin is low.

The header J27 can be used to disconnect the switches and LEDs from the GPIO pins.

Table 1. Switch and LED Pin Descriptions

MCU Pin	Function
PB1.0	Red LED DS5 (LED1)
PB1.1	Red LED DS6 (LED2)
PB1.7	Switch S1
PB2.1	Switch S2

5.2. Analog Terminals (J34)

Several of the C8051F850 port pins used for analog functions are connected to the J34 terminal block. Refer to Table 2 for the J34 terminal block connections.

Table 2. Terminal Block Pin Descriptions (J34)

Terminal Pin	MCU I/O
1	VREF / P0.0
2	GND
3	ADC0.9 / P1.1
4	ADC0.12 / P1.4
5	ADC0.10 / P1.2
6	ADC0.13 / P1.5

5.3. Potentiometer (R13)

The potentiometer is available on P1.2 (ADC0.10). To use the potentiometer, install a shorting block on J27 pins 9 and 10 to connect P1.2 to the potentiometer.

5.4. Voltage and Ground Reference (J32)

The C8051F850 has options to use an external voltage reference on the P0.0 / VREF pin and an external analog ground reference on the P0.1 / AGND pin. The J32 header allows an external supply to clip to pin 1 for AGND and pin 2 for VREF. These signals can then be connected to the MCU by populating a shorting block between pins 3 and 5 for AGND and pins 4 and 6 for VREF. Populating this shorting block for VREF connects P0.0 to the required capacitors for the external reference.

Table 3. Terminal Block Pin Descriptions (J25)

MCU Pin	Analog Signal	Description
P0.0	VREF	Clip external source to J32 pin 2, apply shorting block between pins 4 and 6 to connect to the MCU
P0.1	AGND	Clip external ground to J32 pin 1, apply shorting block between pins 3 and 5 to connect to the MCU

5.5. VDD Power Select Switch (SW1)

The VDD power supply has two power options: UDP motherboard (PWR_VDD_OUT) and on-board +3.3 V regulator power. The VDD Power Select switch is used to select between the two options. The +3.3 V regulator power option is the upper **+3.3_VREG** position and allows the board to be powered from a diode-OR of four power sources: 9 V Power Adapter (J6), the USB connector labeled **COM PORT** (J5), the USB Debug Adapter (J23), or from the UDP motherboard bulk supply (PWR_5.0V_BULK).

5.6. Power LED (DS9)

The blue power LED provides visual feedback when the board is powered through USB, the 9 V power adapter, the USB Debug Adapter, or from the UDP motherboard. The power LED indicates that power is available on the board and the VDD Power Select switch must be configured properly to power the MCU.

5.7. Imeasure Jumper (JP2)

The Imeasure jumper (JP2) allows for easy access to measure the VDD current of the MCU. The shorting block for this header is populated by default, and the direction of current is shown with a silk screen arrow. To measure the supply current, remove the corresponding shorting block and connect a current measurement device across the unpopulated header.

The voltage supply prior to the Imeasure jumper is the VDD pre-measure (VDD_PM) net, which supplies all of the external LEDs, switches, USB COM, and reset pull-up. The VDD after the Imeasure jumper only connects to the MCU.

5.8. Debug Header (J23)

The shrouded 10-pin debug header supports the Silicon Labs USB Debug Adapter. This connector provides a C2 debug connection to the C8051F85x/86x on the MCU card.

5.9. Reset Button (S5)

The reset push-button switch is just below the debug header (J23). Pushing this button will always reset the MCU. Note that pushing this button while the IDE is connected to the MCU will result in the IDE disconnecting from the target.

5.10. UART Connection Options (J7, U2, U4, U5)

The MCU card features a USB virtual COM port (VCP) UART connection via the mini-B USB connector (J5) labeled **COM PORT**. The VCP connection uses the CP210x USB-to-UART bridge chip (U2). The GPIO pins connected to the CP210x device can be enabled or disabled through the J7 header. Table 4 shows the GPIO pins that are routed to the CP210x.

In addition to the CP210x USB-to-UART connection, the MCU card can connect the C8051F850 UART signals with the UDP Motherboard UART signals UART_TX_SYS and UART_RX_SYS using U5. The signals to switch between the two interfaces are UART_VCP_EN and UART_SYS_EN and are controlled by the motherboard. The default selection with or without the motherboard is the CP210x VCP interface using a pull-down resistor R20.

Table 4. CP210x Controlled GPIO Pins

MCU Pin	COM Function
P0.4	UART Transmit
P0.5	UART Receive
VDD	COM VIO

5.11. Port Pin Headers (J24, J24, J26)

All of the MCU port pins are available on the 0.100-inch headers on MCU card. Each connector provides connections to each port, VDD, and ground. Any unused pins on the P2 header are not connected. Some of these port pins are shared with other functions on the board and may be modified as explained in Section 5.13.

C8051F850-DK-UG

5.12. Electronic Board ID (EBID) (U1, J35)

The MCU card has a unique ID that can be read out from the Silicon Labs C8051F990 MCU (U1). This MCU enables software tools to recognize the connected hardware and automatically select the appropriate firmware image.

The EBID device uses two I²C signals to communicate: UDPBUS_SDA_A and UDPBUS_SCL_A. These signals are connected to P0.6 and P0.7 on the C8051F850 MCU through the J25 header. These signals can be disconnected from the MCU during power measurements.

Table 5. Terminal Block Pin Descriptions (J25)

MCU Pin	EBID / UDP Signal
P0.6	UDPBUS_SDA_A
P0.7	UDPBUS_SCL_A

5.13. MCU Port Pin Connections

The MCU card has many UDP connections for use with different I/O cards and the UDP motherboard. Table 6 describes all functions connected to each pin on the C8051F850 MCU. All of the UDP connections are made with populated 0 Ω ohm resistors on the back of the MCU card. To disconnect a signal from the pin, remove the 0 Ω resistor.

Table 6. MCU Card and UDP Pin Functions

MCU Pin	MCU Card Function or UDP Signal				
P0.0	VREF	SPI_SCK_EZR	ADC_VREF	GPIO05	
P0.1	AGND	SPI_MISO_EZR	ADC_VREFGND	GPIO06	EPCA_CH1_MOTOR
P0.2		EXT_INT0	SPI_MOSI_EZR	CP_POS_A	
P0.3		EXT_INT1	SPI_NSS0_EZR	CP_NEG_A	
P0.4		UART_TX_SYS	UART_TX_A		
P0.5		UART_RX_SYS	UART_RX_A	WAKEUP0	
P0.6	UDPBUS_SDA_A	UART_RTS_SYS	UART_RTS_A	I2C_SDA_EZR	EPCA_CH3_MOTOR
P0.7	UDPBUS_SCL_A	UART_CTS_SYS	UART_CTS_A	I2C_SCL_EZR	EPCA_CH5_MOTOR
P1.0	LED1	ADC_IN0	CP_OUT_A		
P1.1	LED2	ADC0.9	ADC_IN1	CP_OUTA_A	
P1.2	Potentiometer	ADC0.10	ADC_IN2	CLKOUT0	
P1.3		PCA_CH0_A	ADC_IN3		
P1.4	ADC0.12	PCA_CH1_A		GPIO02	EPCA_CH0_MOTOR
P1.5	ADC0.13	PCA_CH0_B	WAKEUP1	GPIO03	EPCA_CH2_MOTOR
P1.6		PCA_ECI_A	TIMER_CT_A	GPIO04	EPCA_CH4_MOTOR
P1.7	Switch S1	TIMER_CT_B		GPIO01	
P2.0	C2D				
P2.1	Switch S2	GPIO00			

6. Using the C8051F850 MCU Card with the UDP Motherboard

6.1. MCU Card Header Connections

The MCU card has four connectors with 100 pins each. These 400 pins are directly tied to the UDP motherboard and I/O cards. These signals are named and designed to support a wide variety of features and applications, and the C8051F850 MCU card implements a subset of these connections.

The MCU cards and I/O cards are designed so that a maximum number of functions are shared between each card. This allows a particular type of I/O card to be shared amongst all MCU cards that connect to the same signals.

The MCU card slot includes the following components:

- J1 MCU card connector H1
- J2 MCU card connector H2
- J3 MCU card connector H3
- J4 MCU card connector H4

The C8051F850 MCU card implements the signals described in Table 8, Table 9, Table 10, and Table 11 in the Appendix.

6.2. Shorting Blocks: Factory Defaults

The C8051F850 MCU card comes from the factory with pre-installed shorting blocks on several headers. Figure 11 shows the positions of the factory default shorting blocks.

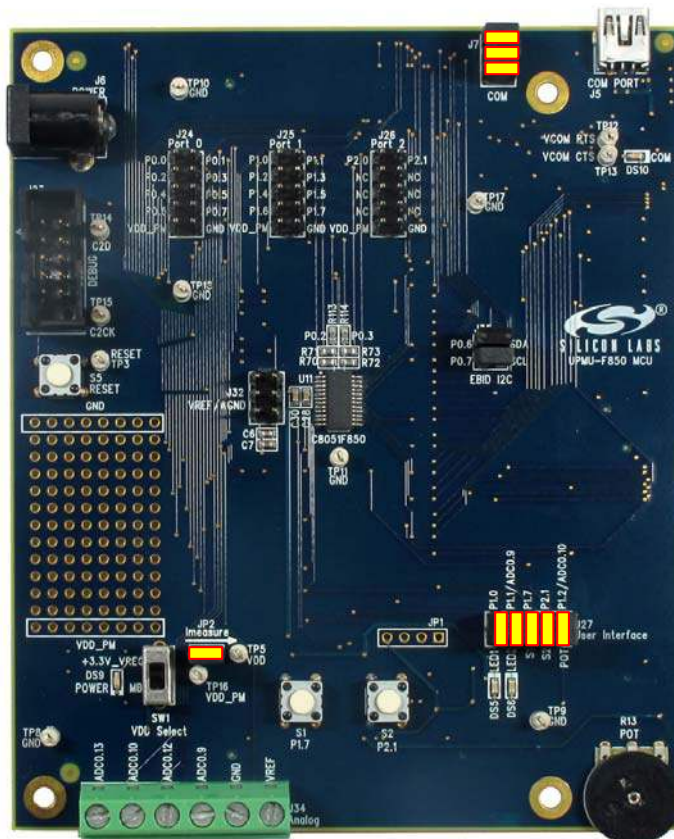

Figure 11. Shorting Blocks: Factory Defaults

A shorting block is installed across the JP2 Imeasure header to enable power to the MCU. Shorting blocks are installed on J7 to enable the virtual COM port. Shorting blocks are also installed on J27 to enable the switches, LEDs, and potentiometer to be connected to GPIO pins.

C8051F850-DK-UG

7. Power Measurement

The C8051F850 MCU card includes a JP2 **Imeasure** jumper for MCU power measurement purposes. The VDD supply on pin 2 of the header connects only to the MCU on the board. The VDD pre-measure (VDD_PM) supply on pin 1 of the JP2 header powers the external LEDs, switches, reset switch, potentiometer, and VCP COM.

7.1. Measuring Power with Fixed VDD

To measure the power of the C8051F850 MCU using the MCU card at a fixed 3.3 V:

1. Connect a USB Debug Adapter to the 10-pin shrouded debug connector (J23).
2. Remove the three shorting blocks from J7.
3. Remove the JP2 **Imeasure** shorting block.
4. Connect a multimeter across (positive side on the left pin, current flow indicated by the silk screen arrow).
5. Move the **VDD Select** switch (SW2) to the upper **+3.3V_VREG** position.
6. Connect the 9 V power adapter to **POWER** (J6).
7. Download the code to the board.
8. Remove the debug adapter connection.
9. Measure the power of the device.

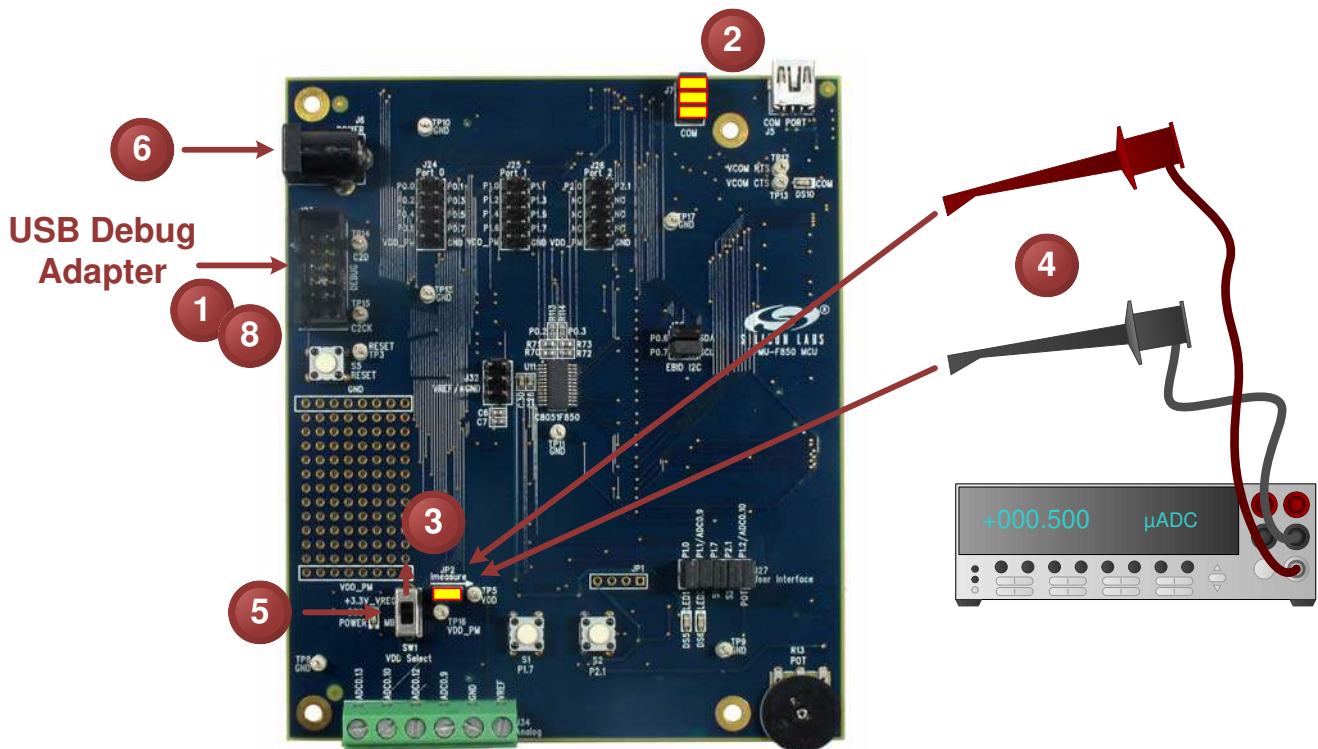

Figure 12. C8051F850 MCU Card Power Measurement Configuration— Fixed VDD

7.2. Measuring Power with Varying VDD

To measure power with a varying VDD:

1. Connect a USB Debug Adapter to the 10-pin shrouded debug connector (J23).
2. Remove the three shorting blocks from J7.
3. Remove the JP2 **Imeasure** shorting block.
4. Connect a multimeter across the JP2 **Imeasure** jumper (positive side on the left pin, current flow indicated by the silk screen arrow).
5. Move the **VDD Select** switch (SW2) to the lower **MB** position.
6. Connect the negative terminal of a bench power supply to board ground.
7. Connect the positive terminal of a bench power supply to the positive side (left pin) of the **Imeasure** jumper. This will ensure that the /RST pin pull-up is powered.

Note: The pull-up resistor on /RST is powered by the VDD pre-measure (VDD_PM) net, which is separated from the VDD net with the **Imeasure** shorting block (JP2) removed. Powering the MCU using VDD without powering the VDD_PM net will prevent the IDE from communicating with the MCU.

8. Download the code to the board.
9. Remove the debug adapter connection.
10. Measure the power of the device.

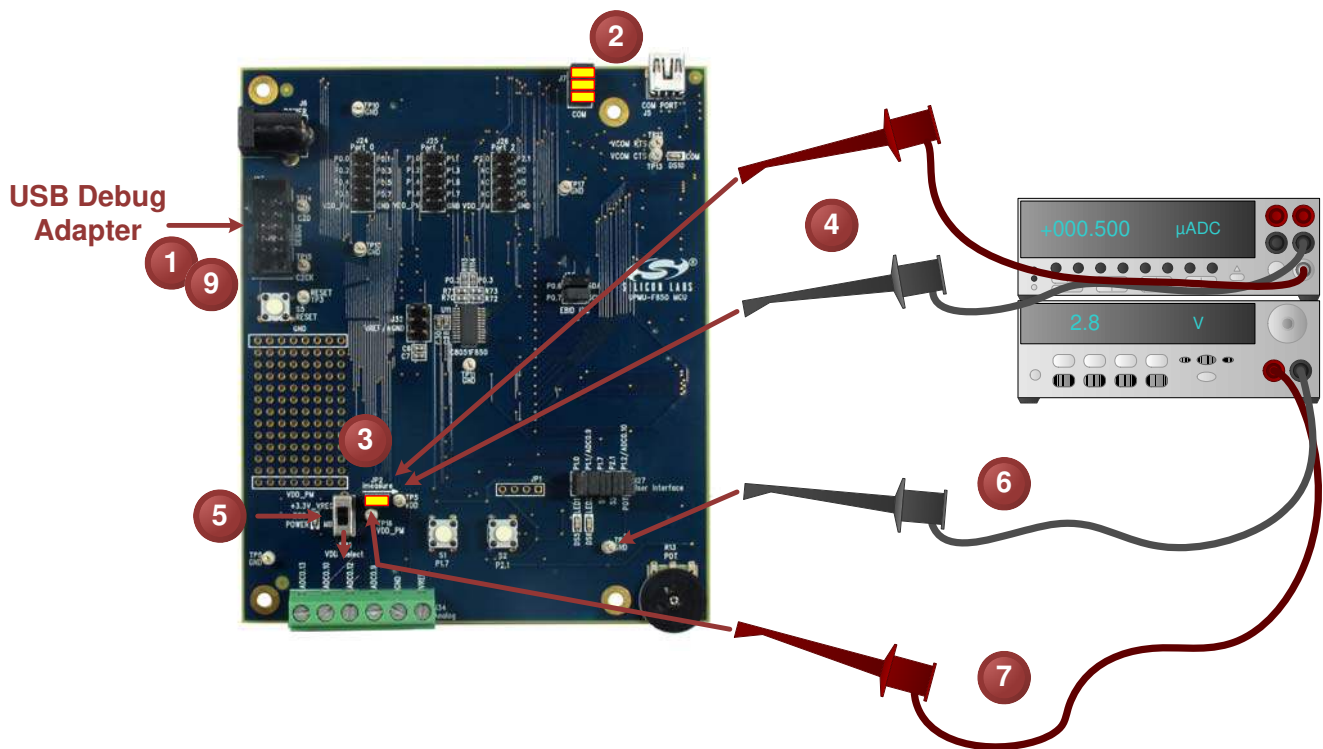

Figure 13. C8051F850 MCU Card Power Measurement Configuration—Varying VDD

8. Known Board Issues

There are no known issues with Revision 200 of the C8051F850 MCU card.

9. Schematics

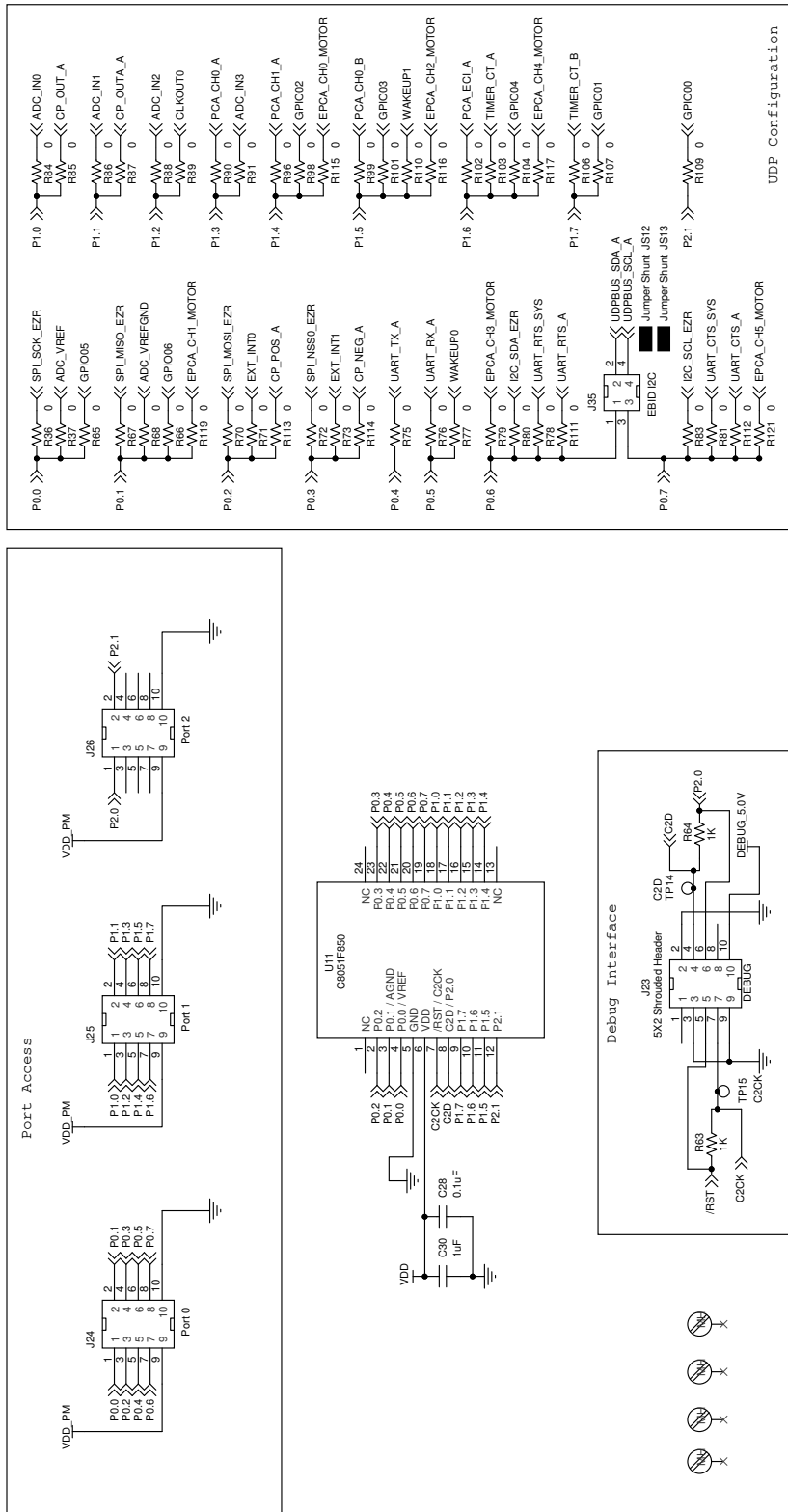

Figure 14. C8051F850 UDP MCU Card Schematic (Revision 200) (1 of 5)

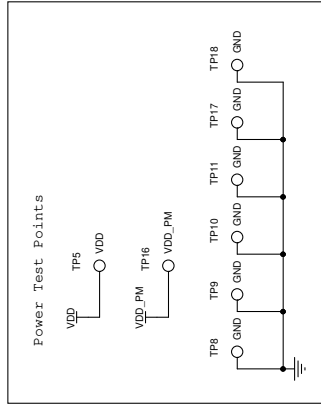
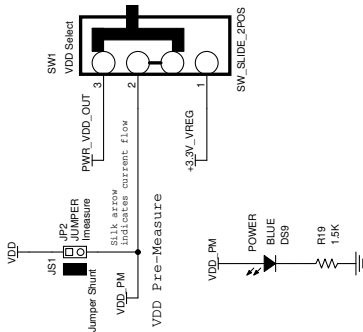
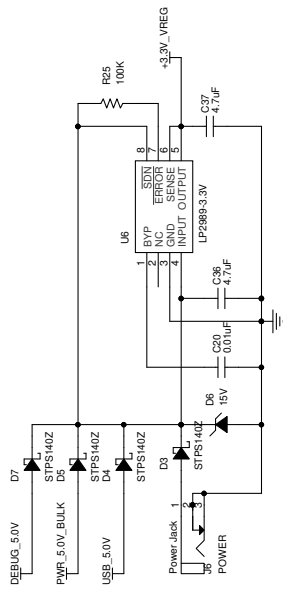
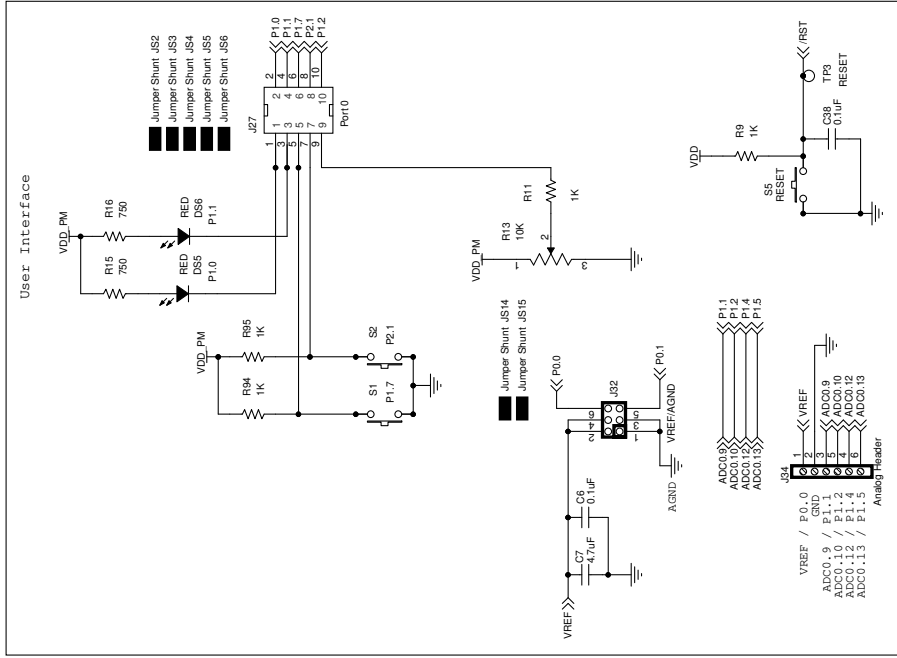

Figure 15. C8051F850 UDP MCU Card Schematic (Revision 200) (2 of 5)

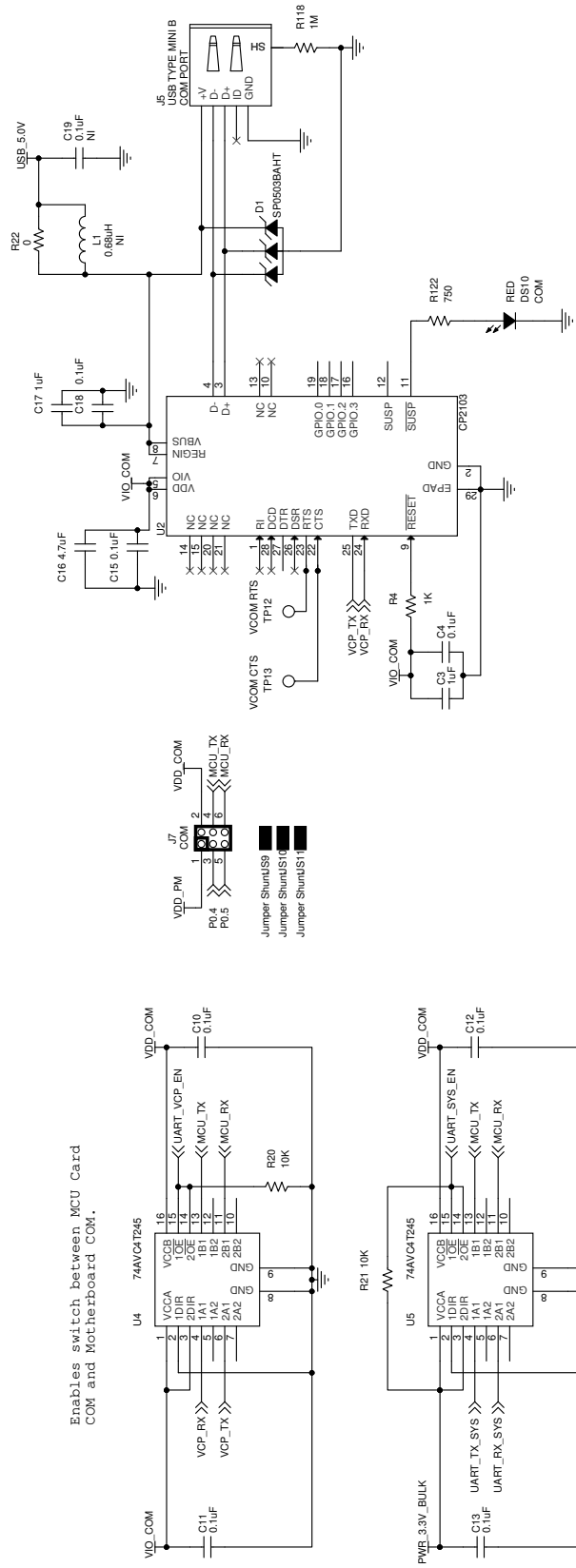

Figure 16. C8051F850 UDP MCU Card Schematic (Revision 200) (3 of 5)

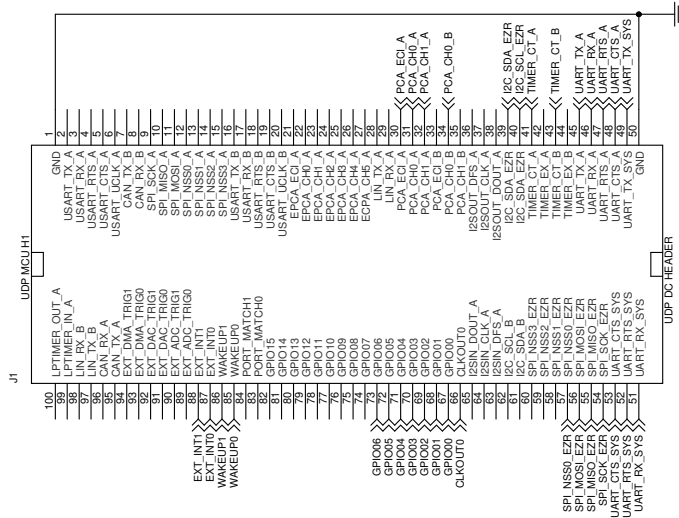
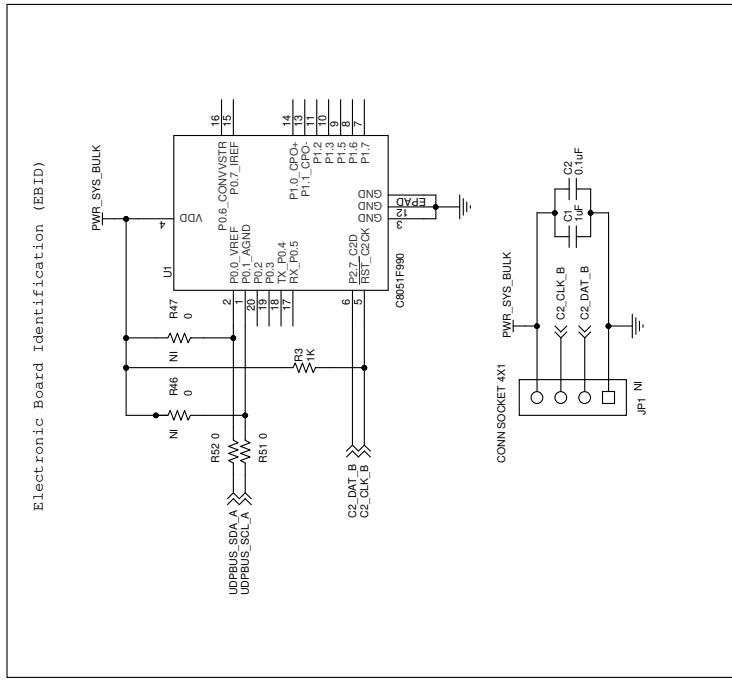

Figure 17. C8051F850 UDP MCU Card Schematic (Revision 200) (4 of 5)

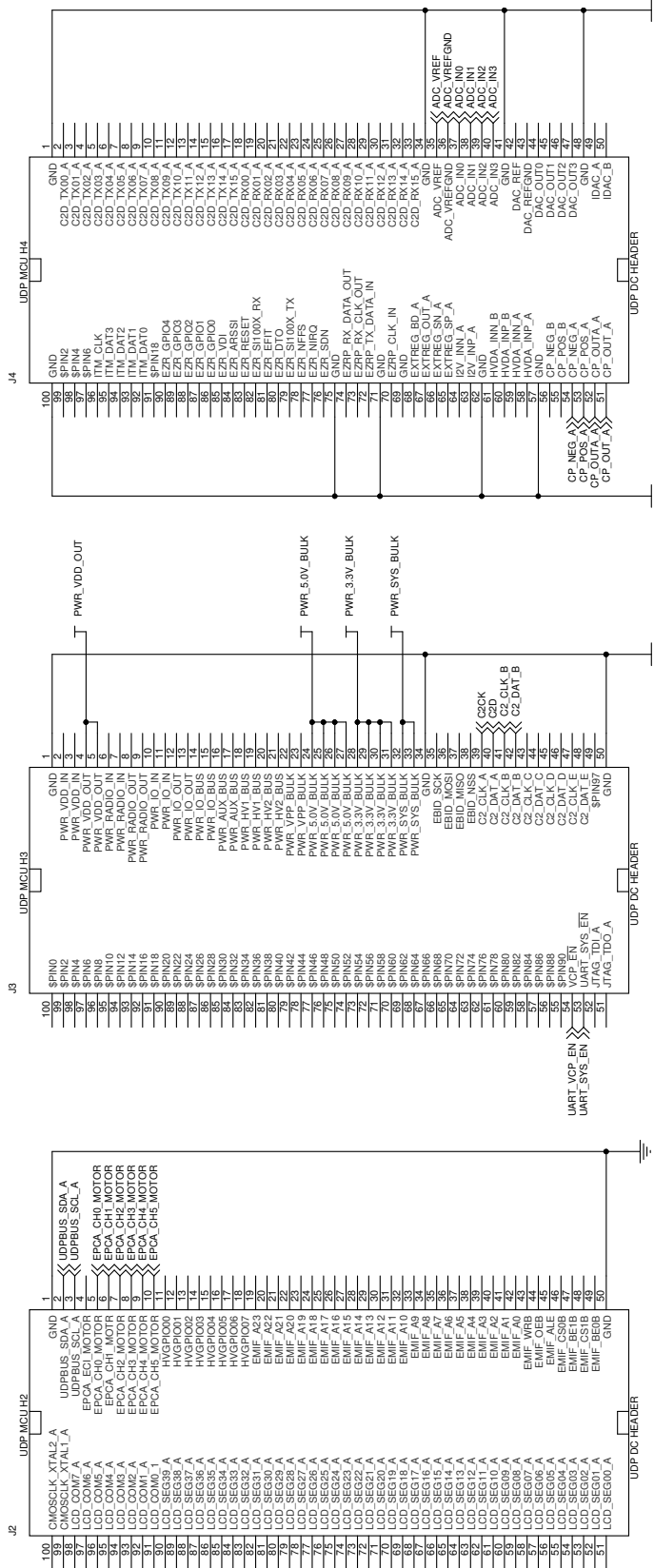

Figure 18. C8051F850 UDP MCU Card Schematic (Revision 200) (5 of 5)

10. Bill of Materials

Table 7. C8051F850 UDP MCU Card Bill of Materials

Reference	Part Number	Source	Description
C1 C3 C17 C30	C0603X7R100-105K	Venkel	1 μ F 10 V \pm 10% X7R 0603
C2 C4 C6 C10 C11 C12 C13 C15 C18 C28 C38	C0603X7R100-104K	Venkel	0.1 μ F 10 V \pm 10% X7R 0603
C20	C0603X7R100-103M	Venkel	0.01 μ F 10 V \pm 20% X7R 0603
C7 C16 C36 C37	C0603X5R6R3-475K	Venkel	4.7 μ F 6.3 V \pm 10% X5R 0603
D1	SP0503BAHTG	Littlefuse	300 mW 20 V TVS SOT143
D3 D4 D5 D7	STPS140Z	ST Semiconductor	1.0 A 40 V Schottky SOD-123
D6	MMSZ5245BT1	On Semiconductor	15 V 500 mW 15 V 5% Zener SOD-123
DS5 DS6 DS10	SML-LX0603IW	LUMEX INC	RED 30 mA LED 0603
DS9	LTST-C190TBKT	LITE-ON Technology Corp	BLUE LED 0603
J1 J2 J3 J4	FX8-100P-SV1	Hirose Electric	UDP DC Header
J23	5103309-1	Tyco	0.1 in. 5x2 Shrouded Header
J24 J25 J26 J27	TSW-105-07-T-D	Samtec	0.1 in. 5x2 Header
J34	1729160	Phoenix Contact	Analog Header Terminal Block 1x6
J35	TSW-102-07-T-D	Samtec	0.1 in. 2x2 Header
J5	54819-0519	Molex	USB Mini B
J6	RAPC722X	Switchcraft Inc.	Power Jack 5 A BARREL
J7 J32	TSW-103-01-L-D	Samtec	0.1 in. 2x3 Header
JP2	TSW-102-07-T-S	Samtec	0.1 in. 1x2 Header
JS1 JS2 JS3 JS4 JS5 JS6 JS9 JS10 JS11	SNT-100-BK-T	Samtec	Jumper Shunt
R118	CR0603-16W-1004F	Venkel	1 M Ω 1/16 W \pm 1% ThickFilm 0603
R13	RV100F-30-4K1B-B10K-B301	Alpha (Taiwan)	10 k Ω 0.03 W 30% Thumbwheel Potentiometer
R15 R16 R122	CR0603-16W-7500F	Venkel	750 Ω 1/10 W \pm 1% ThickFilm 0603
R19	CR0603-10W-1501F	Venkel	1.5 k Ω 1/10 W \pm 1% ThickFilm 0603
R20 R21	CR0603-10W-103J	Venkel	10 k Ω 1/10 W \pm 5% ThickFilm 0603

C8051F850-DK-UG

Table 7. C8051F850 UDP MCU Card Bill of Materials (Continued)

Reference	Part Number	Source	Description
R22 R36 R37 R51 R52 R65 R66 R67 R68 R70 R71 R72 R73 R75 R76 R77 R78 R79 R80 R81 R83 R84 R85 R86 R87 R88 R89 R90 R91 R96 R98 R99 R101 R102 R103 R104 R106 R107 R109 R110 R111 R112 R113 R114 R115 R116 R117 R119 R121	CR0603-16W-000	Venkel	0 Ω 1 A ThickFilm 0603
R25	CR0603-10W-104J	Venkel	100 kΩ 1/10 W ±5% ThickFilm 0603
R3 R4 R9 R11 R63 R64 R94 R95	CR0603-10W-1001F	Venkel	1 kΩ 1/10 W ±1% ThickFilm 0603
S1 S2 S5	EVQ-PAD04M	Panasonic Corp	Momentary Tactile Switch
SW1	OS102011MS2QN1	C&K	.1 A @ 12 V Slide Switch
U1	C8051F990-GM	Silicon Labs	C8051F990 MCU QFN20
U11	C8051F850-A-GU	Silicon Labs	C8051F850 MCU QSOP24
U2	CP2103-GM	Silicon Labs	CP2103 USB-to-UART Bridge QFN28
U4 U5	SN74AVC4T245PW	TI	1.2–3.6 V Translator TSSOP16
U6	LP2989AIMM-3.3/NOPB	National Semiconductor	500 mA LDO MSOP8
Components Not Installed			
C19	C0603X7R100-104K	Venkel	0.1 μF 10 V ±10% X7R 0603 Not Installed (NI)
JP1	SSQ-104-23-T-S	Samtec	CONN SOCKET 4X1 Not Installed (NI)
JS12 JS13 JS14 JS15	SNT-100-BK-T	Samtec	Jumper Shunt Not Installed (NI)
L1	NLV25T-R68J-PF	TDK	0.68 μH 300 mA ±5% GP Not Installed (NI)
R46 R47	CR0603-16W-000	Venkel	0 Ω 1 A ThickFilm 0603 Not Installed (NI)

APPENDIX—MCU CARD HEADER PIN DESCRIPTIONS

Table 8. C8051F850 MCU Card H1 Pin Descriptions (J1)

MCU Card Pin	Signal Name	Description	C8051F850 Pin / Signal
1	GND		
2	USART_TX_A		
3	USART_RX_A		
4	USART_RTS_A		
5	USART_CTS_A		
6	USART_UCLK_A		
7	CAN_TX_B		
8	CAN_RX_B		
9	SPI_SCK_A	SPI A clock	
10	SPI_MISO_A	SPI A master-in, slave-out	
11	SPI_MOSI_A	SPI A master-out, slave-in	
12	SPI_NSS0_A	SPI A slave select 0	
13	SPI_NSS1_A	SPI A slave select 1	
14	SPI_NSS2_A	SPI A slave select 2	
15	SPI_NSS3_A	SPI A slave select 3	
16	USART_TX_B	USART B transmit	
17	USART_RX_B	USART B receive	
18	USART_RTS_B	USART B hardware handshaking	
19	USART_CTS_B	USART B hardware handshaking	
20	USART_UCLK_B	USART B clock	
21	EPCA_ECI_A	EPCA A external clock input	
22	EPCA_CH0_A		
23	EPCA_CH1_A		
24	EPCA_CH2_A		
25	EPCA_CH3_A		
26	EPCA_CH4_A		
27	EPCA_CH5_A		
28	LIN_TX_A		
29	LIN_RX_A		
30	PCA_ECI_A	PCA A external clock input	P1.6
31	PCA_CH0_A		P1.3
32	PCA_CH1_A		P1.4
33	PCA_ECI_B	PCA B external clock input	
34	PCA_CH0_B		P1.5
35	PCA_CH1_B		
36	I2SOUT_DFS_A	I ² S A transmitter word sync (WS)	

C8051F850-DK-UG

Table 8. C8051F850 MCU Card H1 Pin Descriptions (J1) (Continued)

MCU Card Pin	Signal Name	Description	C8051F850 Pin / Signal
37	I2SOUT_CLK_A	I ² S A transmitter clock (SCK)	
38	I2SOUT_DOUT_A	I ² S A transmitter data (SD)	
39	I2C_SDA_EZR	EZRadio I ² C data	P0.6
40	I2C_SCL_EZR	EZRadio I ² C clock	P0.7
41	TIMER_CT_A		P1.6
42	TIMER_EX_A		
43	TIMER_CT_B		P1.7
44	TIMER_EX_B		
45	UART_TX_A	UART A transmit	P0.4
46	UART_RX_A	UART A receive	P0.5
47	UART_RTS_A	UART A hardware handshaking	P0.6
48	UART_CTS_A	UART A hardware handshaking	P0.7
49	UART_TX_SYS	System UART transmit	P0.4
50	GND		
51	UART_RX_SYS	System UART receive	P0.5
52	UART_RTS_SYS	System UART hardware handshaking	P0.6
53	UART_CTS_SYS	System UART hardware handshaking	P0.7
54	SPI_SCK_EZR	EZRadio SPI clock	P0.0
55	SPI_MISO_EZR	EZRadio SPI master-in, slave-out	P0.1
56	SPI_MOSI_EZR	EZRadio SPI master-out, slave-in	P0.2
57	SPI_NSS0_EZR	EZRadio SPI slave select 0	P0.3
58	SPI_NSS1_EZR	EZRadio SPI slave select 1	
59	SPI_NSS2_EZR	EZRadio SPI slave select 2	
60	SPI_NSS3_EZR	EZRadio SPI slave select 3	
61	I2C_SDA_B	I ² C B data	
62	I2C_SCL_B	I ² C B clock	
63	I2SIN_DFS_A	I ² S A receiver word sync (WS)	
64	I2SIN_CLK_A	I ² S A receiver clock (SCK)	
65	I2SIN_DOUT_A	I ² S A receiver data (SD)	
66	CLKOUT0	clock	P1.2
67	GPIO00	General purpose I/O 0	P2.1
68	GPIO01	General purpose I/O 1	P1.7
69	GPIO02	General purpose I/O 2	P1.4
70	GPIO03	General purpose I/O 3	P1.5
71	GPIO04	General purpose I/O 4	P1.6
72	GPIO05	General purpose I/O 5	P0.0
73	GPIO06	General purpose I/O 6	P0.1

Table 8. C8051F850 MCU Card H1 Pin Descriptions (J1) (Continued)

MCU Card Pin	Signal Name	Description	C8051F850 Pin / Signal
74	GPIO07	General purpose I/O 7	
75	GPIO08	General purpose I/O 8	
76	GPIO09	General purpose I/O 9	
77	GPIO10	General purpose I/O 10	
78	GPIO11	General purpose I/O 11	
79	GPIO12	General purpose I/O 12	
80	GPIO13	General purpose I/O 13	
81	GPIO14	General purpose I/O 14	
82	GPIO15	General purpose I/O 15	
83	PORT_MATCH0		
84	PORT_MATCH1		
85	WAKEUP0	MCU low-power wakeup input signal 0	P0.5
86	WAKEUP1	MCU low-power wakeup input signal 1	P1.5
87	EXT_INT0	External interrupt 0	P0.2
88	EXT_INT1	External interrupt 1	P0.3
89	EXT_ADC_TRIG0	External ADC trigger 0	
90	EXT_ADC_TRIG1	External ADC trigger 1	
91	EXT_DAC_TRIG0	External DAC trigger 0	
92	EXT_DAC_TRIG1	External DAC trigger 1	
93	EXT_DMA_TRIG0	External DMA trigger 0	
94	EXT_DMA_TRIG1	External DMA trigger 1	
95	CAN_TX_A		
96	CAN_RX_A		
97	LIN_TX_B		
98	LIN_RX_B		
99	LPTIMER_IN_A		
100	LPTIMER_OUT_A		

C8051F850-DK-UG

Table 9. C8051F850 MCU Card H2 Pin Descriptions (J2)

MCU Card Pin	Signal Name	Description	C8051F850 Pin / Signal
1	GND		
2	UDPBUS_SDA_A	UDP motherboard I ² C A data	P0.6
3	UDPBUS_SCL_A	UDP motherboard I ² C A clock	P0.7
4	EPCA_ECI_MOTOR	Motor EPCA external clock input	
5	EPCA_CH0_MOTOR		P1.4
6	EPCA_CH1_MOTOR		P0.1
7	EPCA_CH2_MOTOR		P1.5
8	EPCA_CH3_MOTOR		P0.6
9	EPCA_CH4_MOTOR		P1.6
10	EPCA_CH5_MOTOR		P0.7
11	HVGPIO0	High Drive I/O 0	
12	HVGPIO1	High Drive I/O 1	
13	HVGPIO2	High Drive I/O 2	
14	HVGPIO3	High Drive I/O 3	
15	HVGPIO4	High Drive I/O 4	
16	HVGPIO5	High Drive I/O 5	
17	HVGPIO6	High Drive I/O 6	
18	HVGPIO7	High Drive I/O 7	
19	EMIF_A23	EMIF muxed AD23m pin (non-muxed A15)	
20	EMIF_A22	EMIF muxed AD22m pin (non-muxed A14)	
21	EMIF_A21	EMIF muxed AD21m pin (non-muxed A13)	
22	EMIF_A20	EMIF muxed AD20m pin (non-muxed A12)	
23	EMIF_A19	EMIF muxed AD19m pin (non-muxed A11)	
24	EMIF_A18	EMIF muxed AD18m pin (non-muxed A10)	
25	EMIF_A17	EMIF muxed AD17m pin (non-muxed A9)	
26	EMIF_A16	EMIF muxed AD16m pin (non-muxed A8)	
27	EMIF_A15	EMIF muxed AD15m pin (non-muxed A7)	
28	EMIF_A14	EMIF muxed AD14m pin (non-muxed A6)	
29	EMIF_A13	EMIF muxed AD13m pin (non-muxed A5)	
30	EMIF_A12	EMIF muxed AD12m pin (non-muxed A4)	
31	EMIF_A11	EMIF muxed AD11m pin (non-muxed A3)	
32	EMIF_A10	EMIF muxed AD10m pin (non-muxed A2)	
33	EMIF_A9	EMIF muxed AD9m pin (non-muxed A1)	
34	EMIF_A8	EMIF muxed AD8m pin (non-muxed A0)	
35	EMIF_A7	EMIF muxed AD7m pin (non-muxed D7)	
36	EMIF_A6	EMIF muxed AD6m pin (non-muxed D6)	
37	EMIF_A5	EMIF muxed AD5m pin (non-muxed D5)	

Table 9. C8051F850 MCU Card H2 Pin Descriptions (J2) (Continued)

MCU Card Pin	Signal Name	Description	C8051F850 Pin / Signal
38	EMIF_A4	EMIF muxed AD4m pin (non-muxed D4)	
39	EMIF_A3	EMIF muxed AD3m pin (non-muxed D3)	
40	EMIF_A2	EMIF muxed AD2m pin (non-muxed D2)	
41	EMIF_A1	EMIF muxed AD1m pin (non-muxed D1)	
42	EMIF_A0	EMIF muxed AD0m pin (non-muxed D0)	
43	EMIF_WRB	EMIF write signal	
44	EMIF_OEB	EMIF output enable	
45	EMIF_ALE	EMIF address latch enable	
46	EMIF_CS0B	EMIF chip select 0	
47	EMIF_BE1B	EMIF output byte enable 1	
48	EMIF_CS1B	EMIF chip select 1	
49	EMIF_BE0B	EMIF output byte enable 0	
50	GND		
51	LCD_SEG00_A		
52	LCD_SEG01_A		
53	LCD_SEG02_A		
54	LCD_SEG03_A		
55	LCD_SEG04_A		
56	LCD_SEG05_A		
57	LCD_SEG06_A		
58	LCD_SEG07_A		
59	LCD_SEG08_A		
60	LCD_SEG09_A		
61	LCD_SEG10_A		
62	LCD_SEG11_A		
63	LCD_SEG12_A		
64	LCD_SEG13_A		
65	LCD_SEG14_A		
66	LCD_SEG15_A		
67	LCD_SEG16_A		
68	LCD_SEG17_A		
69	LCD_SEG18_A		
70	LCD_SEG19_A		
71	LCD_SEG20_A		
72	LCD_SEG21_A		
73	LCD_SEG22_A		
74	LCD_SEG23_A		

C8051F850-DK-UG

Table 9. C8051F850 MCU Card H2 Pin Descriptions (J2) (Continued)

MCU Card Pin	Signal Name	Description	C8051F850 Pin / Signal
75	LCD_SEG24_A		
76	LCD_SEG25_A		
77	LCD_SEG26_A		
78	LCD_SEG27_A		
79	LCD_SEG28_A		
80	LCD_SEG29_A		
81	LCD_SEG30_A		
82	LCD_SEG31_A		
83	LCD_SEG32_A		
84	LCD_SEG33_A		
85	LCD_SEG34_A		
86	LCD_SEG35_A		
87	LCD_SEG36_A		
88	LCD_SEG37_A		
89	LCD_SEG38_A		
90	LCD_SEG39_A		
91	LCD_COM0_A		
92	LCD_COM1_A		
93	LCD_COM2_A		
94	LCD_COM3_A		
95	LCD_COM4_A		
96	LCD_COM5_A		
97	LCD_COM6_A		
98	LCD_COM7_A		
99	CMOSCLK_XTAL1_A	MCU XTAL1 pin for external oscillators	
100	CMOSCLK_XTAL2_A	MCU XTAL2 pin for external oscillators	

Table 10. C8051F850 MCU Card H3 Pin Descriptions (J3)

MCU Card Pin	Description	Description	C8051F850 Pin / Signal
1	GND		
2	PWR_VDD_IN	Power input for powering the MCU card from a power source other than the UDP motherboard	
3	PWR_VDD_IN		
4	PWR_VDD_OUT	Power input for the MCU card	
5	PWR_VDD_OUT		
6	PWR_RADIO_IN	Power input for powering the radio test card from a power source other than the UDP motherboard	
7	PWR_RADIO_IN		
8	PWR_RADIO_OUT	Power input for the radio test card	
9	PWR_RADIO_OUT		
10	PWR_IO_IN	Power input for powering the I/O card from a power source other than the UDP motherboard	
11	PWR_IO_IN		
12	PWR_IO_OUT	Power input for the I/O card	
13	PWR_IO_OUT		
14	PWR_IO_BUS	Connects power from the MCU card to the radio and I/O cards	
15	PWR_IO_BUS		
16	PWR_AUX_BUS	Connects power from the MCU card to the radio and I/O cards	
17	PWR_AUX_BUS		
18	PWR_HV1_BUS	High Drive I/O power 1	
19	PWR_HV1_BUS		
20	PWR_HV2_BUS	High Drive I/O power 2	
21	PWR_HV2_BUS		
22	PWR_VPP_BULK	VPP programming voltage	
23	PWR_VPP_BULK		
24	PWR_5.0_BULK	5.0 V power from the UDP motherboard	
25	PWR_5.0_BULK		
26	PWR_5.0_BULK		
27	PWR_5.0_BULK		
28	VCC_3.3V	3.3 V power from the UDP motherboard	
29	VCC_3.3V		
30	VCC_3.3V		
31	VCC_3.3V		
32	PWR_SYS_BULK	3.3 V power supply for EBID devices	
33	PWR_SYS_BULK		
34	GND		
35	EBID_SCK	EBID SPI clock	
36	EBID_MOSI	EBID SPI master-out, slave in	
37	EBID_MISO	EBID SPI master-in, slave-out	

C8051F850-DK-UG

Table 10. C8051F850 MCU Card H3 Pin Descriptions (J3) (Continued)

MCU Card Pin	Description	Description	C8051F850 Pin / Signal
38	EBID_NSS	EBID SPI slave select	
39	C2_CLK_A	C2 interface A clock, JTAG interface A TCK, Serial Wire SWCLK	RST/C2CK
40	C2_DAT_A	C2 interface A data, JTAG interface A TMS, Serial Wire SWDIO	C2D/P2.0
41	C2_CLK_B	C2 interface B clock	
42	C2_DAT_B	C2 interface B data	
43	C2_CLK_C	C2 interface C clock	
44	C2_DAT_C	C2 interface C data	
45	C2_CLK_D	C2 interface D clock	
46	C2_DAT_D	C2 interface D data	
47	C2_CLK_E	C2 interface E clock	
48	C2_DAT_E	C2 interface E data	
49	nc	no connect	
50	GND		
51	JTAG_TDO_A	JTAG interface A data out (TDO), Serial Wire SWO	
52	JTAG_TDI_A	JTAG interface A data in (TDI)	
53	VCP_EN	Selects the USB-to-USART motherboard path	
54	UART_SYS_EN	Selects the USB-to-USART motherboard path	
55	H3_55	General purpose signal	
56	H3_56	General purpose signal	
57	H3_57	General purpose signal	
58	H3_58	General purpose signal	
59	H3_59	General purpose signal	
60	H3_60	General purpose signal	
61	H3_61	General purpose signal	
62	H3_62	General purpose signal	
63	H3_63	General purpose signal	
64	H3_64	General purpose signal	
65	H3_65	General purpose signal	
66	H3_66	General purpose signal	
67	H3_67	General purpose signal	
68	H3_68	General purpose signal	
69	H3_69	General purpose signal	
70	H3_70	General purpose signal	
71	H3_71	General purpose signal	
72	H3_72	General purpose signal	
73	H3_73	General purpose signal	

Table 10. C8051F850 MCU Card H3 Pin Descriptions (J3) (Continued)

MCU Card Pin	Description	Description	C8051F850 Pin / Signal
74	H3_74	General purpose signal	
75	H3_75	General purpose signal	
76	H3_76	General purpose signal	
77	H3_77	General purpose signal	
78	H3_78	General purpose signal	
79	H3_79	General purpose signal	
80	H3_80	General purpose signal	
81	H3_81	General purpose signal	
82	H3_82	General purpose signal	
83	H3_83	General purpose signal	
84	H3_84	General purpose signal	
85	H3_85	General purpose signal	
86	H3_86	General purpose signal	
87	H3_87	General purpose signal	
88	H3_88	General purpose signal	
89	H3_89	General purpose signal	
90	H3_90	General purpose signal	
91	H3_91	General purpose signal	
92	H3_92	General purpose signal	
93	H3_93	General purpose signal	
94	H3_94	General purpose signal	
95	H3_95	General purpose signal	
96	H3_96	General purpose signal	
97	H3_97	General purpose signal	
98	H3_98	General purpose signal	
99	H3_99	General purpose signal	
100	H3_100	General purpose signal	

C8051F850-DK-UG

Table 11. C8051F850 MCU Card H4 Pin Descriptions (J4)

MCU Card Pin	Description	Description	C8051F850 Pin / Signal
1	GND		
2	C2D_TX00_A	Capacitive Sensing output 0	
3	C2D_TX01_A	Capacitive Sensing output 1	
4	C2D_TX02_A	Capacitive Sensing output 2	
5	C2D_TX03_A	Capacitive Sensing output 3	
6	C2D_TX04_A	Capacitive Sensing output 4	
7	C2D_TX05_A	Capacitive Sensing output 5	
8	C2D_TX06_A	Capacitive Sensing output 6	
9	C2D_TX07_A	Capacitive Sensing output 7	
10	C2D_TX08_A	Capacitive Sensing output 8	
11	C2D_TX09_A	Capacitive Sensing output 9	
12	C2D_TX10_A	Capacitive Sensing output 10	
13	C2D_TX11_A	Capacitive Sensing output 11	
14	C2D_TX12_A	Capacitive Sensing output 12	
15	C2D_TX13_A	Capacitive Sensing output 13	
16	C2D_TX14_A	Capacitive Sensing output 14	
17	C2D_TX15_A	Capacitive Sensing output 15	
18	C2D_RX00_A	Capacitive Sensing input 0	
19	C2D_RX01_A	Capacitive Sensing input 1	
20	C2D_RX02_A	Capacitive Sensing input 2	
21	C2D_RX03_A	Capacitive Sensing input 3	
22	C2D_RX04_A	Capacitive Sensing input 4	
23	C2D_RX05_A	Capacitive Sensing input 5	
24	C2D_RX06_A	Capacitive Sensing input 6	
25	C2D_RX07_A	Capacitive Sensing input 7	
26	C2D_RX08_A	Capacitive Sensing input 8	
27	C2D_RX09_A	Capacitive Sensing input 9	
28	C2D_RX10_A	Capacitive Sensing input 10	
29	C2D_RX11_A	Capacitive Sensing input 11	
30	C2D_RX12_A	Capacitive Sensing input 12	
31	C2D_RX13_A	Capacitive Sensing input 13	
32	C2D_RX14_A	Capacitive Sensing input 14	
33	C2D_RX15_A	Capacitive Sensing input 15	
34	GND		
35	ADC_VREF	ADC voltage reference	P0.0
36	ADC_VREFGND	ADC VREF ground	P0.1
37	ADC_IN0		P1.0

Table 11. C8051F850 MCU Card H4 Pin Descriptions (J4) (Continued)

MCU Card Pin	Description	Description	C8051F850 Pin / Signal
38	ADC_IN1		P1.1
39	ADC_IN2		P1.2
40	ADC_IN3		P1.3
41	GND		
42	DAC_VREF	DAC voltage reference	
43	DAC_VREFGND	DAC voltage reference ground	
44	DAC_OUT0		
45	DAC_OUT1		
46	DAC_OUT2		
47	DAC_OUT3		
48	GND		
49	IDAC_A	IDAC A output	
50	IDAC_B	IDAC B output	
51	CP_OUT_A	Comparator A synchronous output	P1.0
52	CP_OUTA_A	Comparator A asynchronous output	P1.1
53	CP_POS_A	Comparator A positive input	P0.2
54	CP_NEG_A	Comparator A negative input	P0.3
55	CP_POS_B	Comparator B positive input	
56	CP_NEG_B		
57	GND		
58	HVDA_INP_A	High Voltage Differential Amplifier A positive input	
59	HVDA_INN_A	High Voltage Differential Amplifier A negative input	
60	HVDA_INP_B	High Voltage Differential Amplifier B positive input	
61	HVDA_INN_B	High Voltage Differential Amplifier B negative input	
62	GND		
63	I2V_INP_A	Current-to-Voltage converter A input 0	
64	I2V_INN_A	Current-to-Voltage converter A input 1	
65	EXTREG_SP_A	External Voltage Regulator SP input	
66	EXTREG_SN_A	External Voltage Regulator SN input	
67	EXTREG_OUT_A	External Voltage Regulator OUT output	
68	EXTREG_BD_A	External Voltage Regulator base drive output	
69	GND		
70	EZRP_CLK_IN	Radio test card clock input (SMA connector)	
71	GND		
72	EZRP_TX_DATA_IN	Radio test card transmit data input (SMA connector)	
73	EZRO_RX_CLK_OUT	Radio test card receive clock output (SMA connector)	
74	EZRP_RX_DATA_OUT	Radio test card receive data output (SMA connector)	

C8051F850-DK-UG

Table 11. C8051F850 MCU Card H4 Pin Descriptions (J4) (Continued)

MCU Card Pin	Description	Description	C8051F850 Pin / Signal
75	GND		
76	EZRP_SDN	Radio test card peripheral shutdown	
77	EZRP_NIRQ	Radio test card peripheral interrupt status	
78	EZR_NFFS		
79	EZR_SI100X_TX	Radio test card Si100x transmit	
80	EZR_DTO		
81	EZR_FFIT		
82	EZR_SI100X_RX	Radio test card Si100x receive	
83	EZR_RESET	Radio test card reset	
84	EZR_ARSSI		
85	EZR_VDI		
86	EZR_GPIO0	Radio test card general purpose I/O 0	
87	EZR_GPIO1	Radio test card general purpose I/O 1	
88	EZR_GPIO2	Radio test card general purpose I/O 2	
89	EZR_GPIO3	Radio test card general purpose I/O 3	
90	EZR_GPIO4	Radio test card general purpose I/O 4	
91	H4_91	General purpose signal	
92	ITM_DAT0		
93	ITM_DAT1		
94	ITM_DAT2		
95	ITM_DAT3		
96	ITM_CLK		
97	H4_97	General purpose signal	
98	H4_98	General purpose signal	
99	H4_99	General purpose signal	
100	GND		



Simplicity Studio

One-click access to MCU and wireless tools, documentation, software, source code libraries & more. Available for Windows, Mac and Linux!



IoT Portfolio
www.silabs.com/IoT



SW/HW
www.silabs.com/simplicity



Quality
www.silabs.com/quality



Support and Community
community.silabs.com

Disclaimer

Silicon Laboratories intends to provide customers with the latest, accurate, and in-depth documentation of all peripherals and modules available for system and software implementers using or intending to use the Silicon Laboratories products. Characterization data, available modules and peripherals, memory sizes and memory addresses refer to each specific device, and "Typical" parameters provided can and do vary in different applications. Application examples described herein are for illustrative purposes only. Silicon Laboratories reserves the right to make changes without further notice and limitation to product information, specifications, and descriptions herein, and does not give warranties as to the accuracy or completeness of the included information. Silicon Laboratories shall have no liability for the consequences of use of the information supplied herein. This document does not imply or express copyright licenses granted hereunder to design or fabricate any integrated circuits. The products must not be used within any Life Support System without the specific written consent of Silicon Laboratories. A "Life Support System" is any product or system intended to support or sustain life and/or health, which, if it fails, can be reasonably expected to result in significant personal injury or death. Silicon Laboratories products are generally not intended for military applications. Silicon Laboratories products shall under no circumstances be used in weapons of mass destruction including (but not limited to) nuclear, biological or chemical weapons, or missiles capable of delivering such weapons.

Trademark Information

Silicon Laboratories Inc., Silicon Laboratories, Silicon Labs, SiLabs and the Silicon Labs logo, CMEMS®, EFM, EFM32, EFR, Energy Micro, Energy Micro logo and combinations thereof, "the world's most energy friendly microcontrollers", Ember®, EZLink®, EZMac®, EZRadio®, EZRadioPRO®, DSPLL®, ISOmodem®, Precision32®, ProSLIC®, SiPHY®, USBXpress® and others are trademarks or registered trademarks of Silicon Laboratories Inc. ARM, CORTEX, Cortex-M3 and THUMB are trademarks or registered trademarks of ARM Holdings. Keil is a registered trademark of ARM Limited. All other products or brand names mentioned herein are trademarks of their respective holders.



SILICON LABS

Silicon Laboratories Inc.
 400 West Cesar Chavez
 Austin, TX 78701
 USA

<http://www.silabs.com>