

No OF POSITIONS
-03, -04, -05, -08, -10, -13, -17, -20, -25
LEAD STYLE
-01

PLATING SPECIFICATION
-L: 10µ" SELECTIVE GOLD IN CONTACT AREA, MATTE TIN ON TAIL (USE T-1SXX-XX-L)
-F: 3µ" SELECTIVE GOLD IN CONTACT AREA, MATTE TIN ON TAIL (USE T-1SXX-XX-F)
-S: 30µ" SELECTIVE GOLD IN CONTACT AREA, MATTE TIN ON TAIL (USE T-1SXX-XX-S)
-H: 30µ" GOLD IN CONTACT AREA, 3µ" GOLD ON TAIL (USE T-1SXX-XX-H)
-LM: 10µ" SELECTIVE GOLD IN CONTACT AREA, MATTE TIN ON TAIL (USE T-1SXX-XX-L)
-SM: 30µ" SELECTIVE GOLD IN CONTACT AREA, MATTE TIN ON TAIL (USE T-1SXX-XX-S)
-FM: 3µ" SELECTIVE GOLD IN CONTACT AREA, MATTE TIN ON TAIL (USE T-1SXX-XX-F)

PACKAGING (SEE NOTES 9 & 10)
BLANK: TUBES (SEE NOTE 8)
-TR: TAPE & REEL PACKAGING (FOR -D-SM, -D-SM-P, & -D-SM-K ONLY) (NOT AVAILABLE ON -D-SM-LC)
-FR: FULL REEL QTY TAPE & REEL
-P: PICK & PLACE PAD (FOR -D-SM ONLY) (FOR -03 & -04, USE PPP-25, SEE FIG 7, SHT 3) (FOR -05 THRU -25, USE PPP-48, SEE FIG 2)
-K: POLYIMIDE FILM (SEE FIG 3) (NOT AVAILABLE ON 3 POSITIONS)

OPTION
-LC: LOCKING CLIP (FOR -D-SM ONLY) (SEE NOTE 7)

POLARIZED OPTION
-XX = PIN OMITTED (N/A ON -RA OPTION)

TAIL OPTION
(LEAVE BLANK FOR THROUGH HOLE, SEE FIG 4, SHEET 2, USE T-1S63-01-XX)
-SM: SURFACE MOUNT (USE T-1S15-02-XX)
-RA: RIGHT ANGLE (USE T-1S63-02-XX AND T-1S63-03-XX) (SEE FIG 5, SHEET 2)

ROW SPECIFICATION
-D: DOUBLE

DO NOT SCALE FROM THIS PRINT

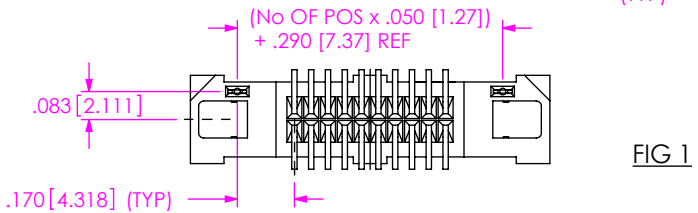
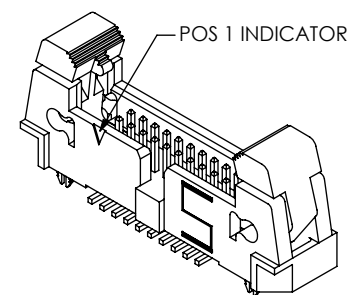
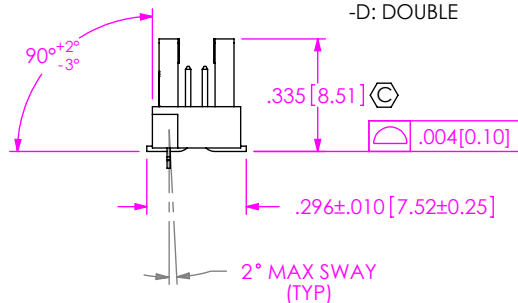
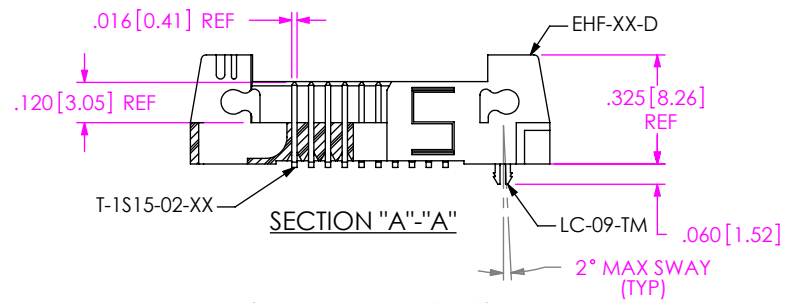

- NOTES:
1. REPRESENTS A CRITICAL DIMENSION.
 2. COPLANARITY TO BE WITHIN .004[0.10].
 3. MAXIMUM BURR ALLOWANCE: .0015 [0.038].
 4. MINIMUM PUSHOUT FORCE: 1 LB.
 5. MAXIMUM ALLOWABLE BOW: .002[0.05] INCH/INCH AFTER ASSEMBLY.
 6. NOTE DELETED.
 7. DUE TO THE HIGH AMOUNT OF INSERTION FORCE NEEDED, THE -LC OPTION IS NOT COMPATIBLE WITH AUTO PLACEMENT. SAMTEC RECOMMENDS MANUAL PLACEMENT FOR ALL ASSEMBLIES WITH THE -LC OPTION.
 8. TUBES ARE STANDARD PACKAGING
 9. ORDERS WILL BE PACKAGED ACCORDING TO THE SAMTEC PACKAGING EFFICIENCY STANDARDS (SPES) FOUND ON WWW.SAMTEC.COM
 10. ATTACH LABEL -4X2 TO EACH REEL.

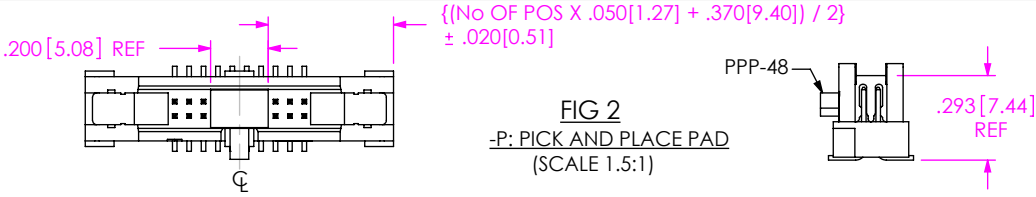
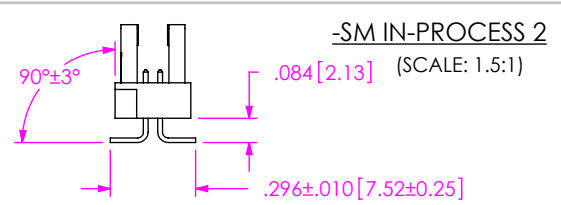
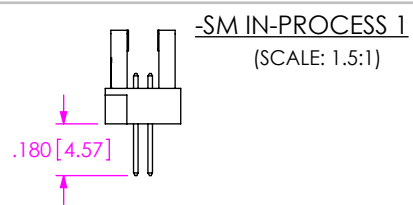

UNLESS OTHERWISE SPECIFIED, DIMENSIONS ARE IN INCHES.
TOLERANCES ARE:
DECIMALS ANGLES
.XX: ±.01[0.3]
.XXX: ±.005[0.13]
.XXXX: ±.0020[0.051]

PROPRIETARY NOTE
THIS DOCUMENT CONTAINS CONFIDENTIAL AND PROPRIETARY INFORMATION AND ALL DESIGN, MANUFACTURING, REPRODUCTION, USE, PATENT RIGHTS AND SALES RIGHTS ARE EXPRESSLY RESERVED BY SAMTEC, INC. THIS DOCUMENT SHALL NOT BE DISCLOSED, IN WHOLE OR PART, TO ANY UNAUTHORIZED PERSON OR ENTITY NOR REPRODUCED, TRANSFERRED OR INCORPORATED IN ANY OTHER PROJECT IN ANY MANNER WITHOUT THE EXPRESS WRITTEN CONSENT OF SAMTEC, INC.



520 PARK EAST BLVD, NEW ALBANY, IN 47150
PHONE: 812-944-6733 FAX: 812-948-5047
e-Mail: info@SAMTEC.com code: 53322

MATERIAL: DO NOT SCALE DRAWING
INSULATOR: VECTRA E130I, COLOR BLACK 50% REGRIND
TERMINAL: PHOS BRONZE 510 SPRING
SHEET SCALE: 1.75:1

DESCRIPTION: .050 EJECTOR HEADER ASSEMBLY
DWG. NO. EHF-1XX-01-X-D-XX-XX-XX-X-XX
BY: ERIC M. 08/17/01 SHEET 1 OF 3

$\phi .295 [7.50]$ REF $\{(\text{NO OF POS X } .050 [1.27] + .275 [6.98]) / 2\} \pm .020 [0.51]$

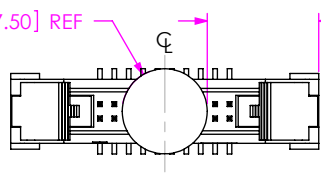

(SCALE: 1.5:1)

FIG 3

-K: POLYIMIDE FILM
(K-DOT-.295-.406-.005)

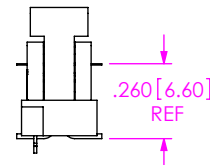

FIG 4
STANDARD THROUGH HOLE
(SHOWN: EHF-110-01-XX-D)
(SAME AS FIG 1, UNLESS OTHERWISE STATED)

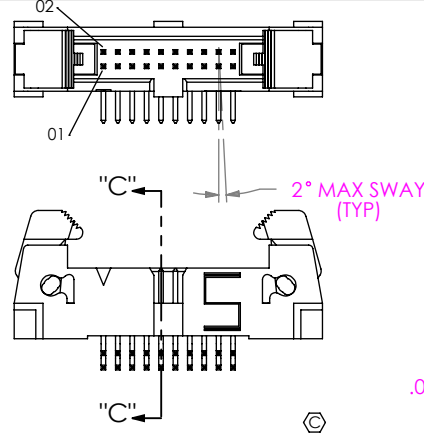
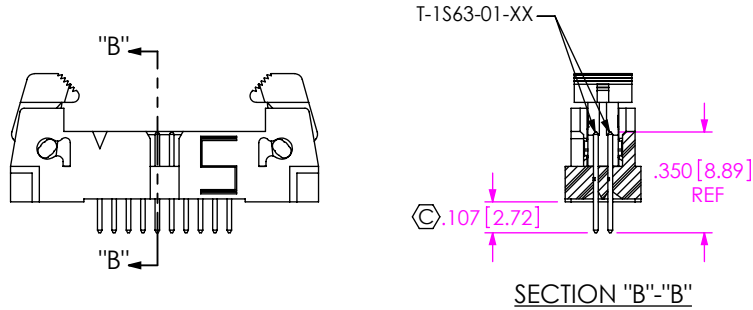
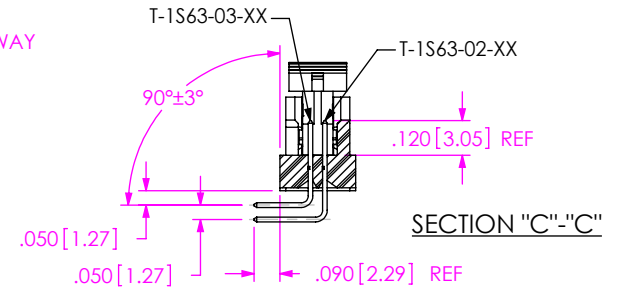

FIG 5

-RA: RIGHT ANGLE OPTION
(SHOWN: EHF-110-01-XX-D-RA)
(SAME AS FIG 1, UNLESS OTHERWISE STATED)



PACKAGING VIEWS

(LOAD PARTS WITH POSITION #1 INDICATOR
IN SAME DIRECTION AS ARROW ON TUBE)

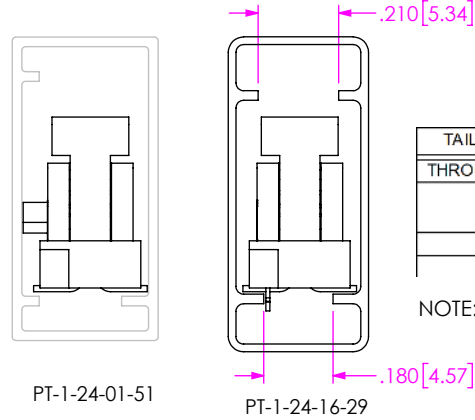

TAIL OPTION	OPTION	PACKAGING TUBE	PLUG
THROUGH HOLE	N/A	PT-1-24-05-09	TP-07
-SM	NONE, -LC, -K, -LC-K	PT-1-24-16-29	
-SM	-P, -LC-P	PT-1-24-01-51	TP-13
-RA	N/A	PT-1-24-01-52	

NOTE: ARROW POINTS INTO THE SHEET AWAY FROM YOU.

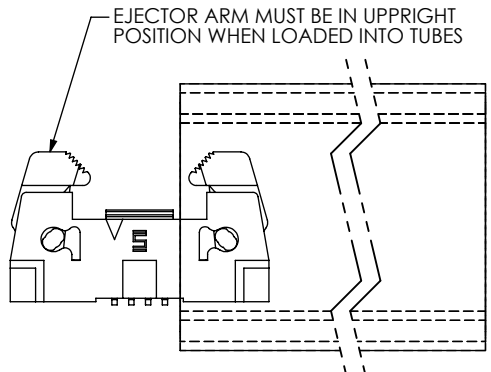

-RA IN-PROCESS 1

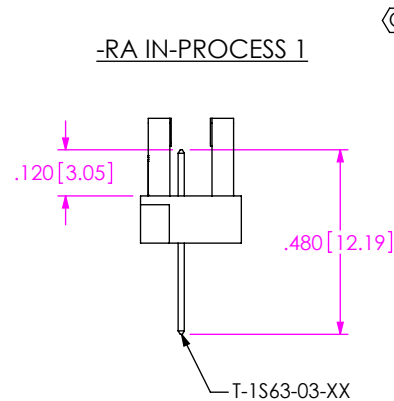

-RA IN-PROCESS 2

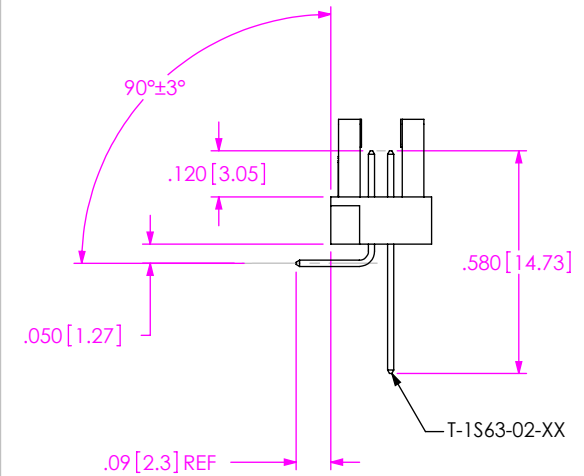

c:\enterprisevault\DWG\MISC\MKTG\EHF-1XX-01-X-D-XX-XX-XX-XX-MKT.SLDDRW

PROPRIETARY NOTE
THIS DOCUMENT CONTAINS CONFIDENTIAL AND PROPRIETARY INFORMATION AND ALL DESIGN, MANUFACTURING, REPRODUCTION, USE, PATENT RIGHTS AND SALES RIGHTS ARE EXPRESSLY RESERVED BY SAMTEC, INC. THIS DOCUMENT SHALL NOT BE DISCLOSED, IN WHOLE OR PART, TO ANY UNAUTHORIZED PERSON OR ENTITY NOR REPRODUCED, TRANSFERRED OR INCORPORATED IN ANY OTHER PROJECT IN ANY MANNER WITHOUT THE EXPRESS WRITTEN CONSENT OF SAMTEC, INC.

DO NOT SCALE DRAWING

SHEET SCALE: 2:1



520 PARK EAST BLVD, NEW ALBANY, IN 47150
PHONE: 812-944-6733 FAX: 812-948-5047
e-Mail: info@SAMTEC.com code: 55322

DESCRIPTION: .050 EJECTOR HEADER ASSEMBLY

DWG. NO. EHF-1XX-01-X-D-XX-XX-XX-X-XX

BY: ERIC M. 08/17/01 SHEET 2 OF 3

FIG 6

-SM: SURFACE MOUNT OPTION
(SHOWN: EHF-110-01-XX-D-SM-LC)
(SHOWN WITH LATCHES OPEN)

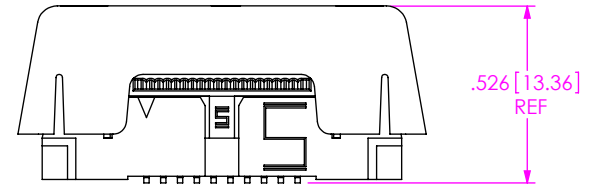
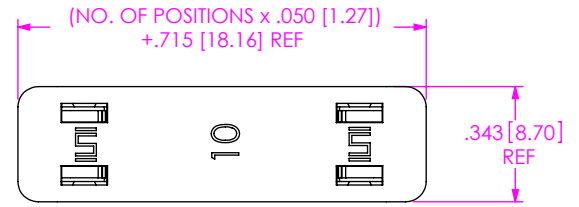
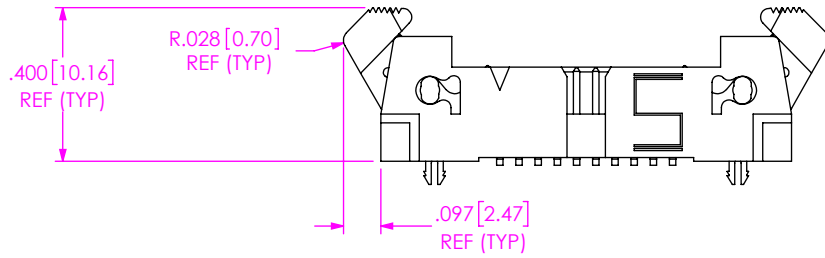

FIG 8
APPLICATION VIEW
EHF MATED WITH FFSD AND ECF

FIG 7

-03 & -04 PICK AND PLACE PAD
(SHOWN: EHF-104-01-XX-D-SM-XX-P)

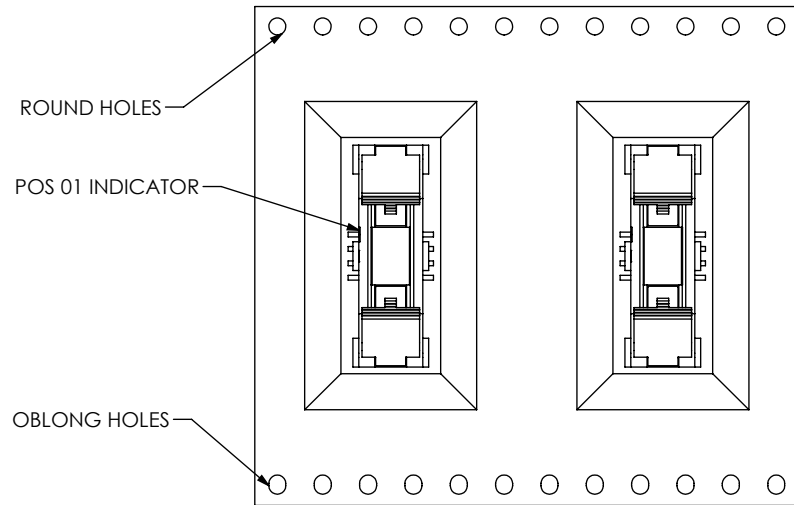
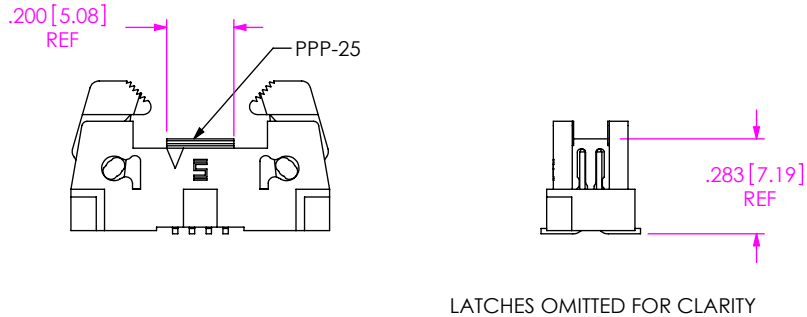
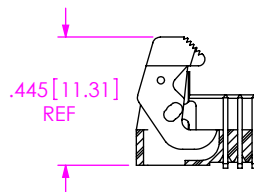
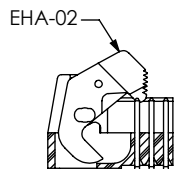
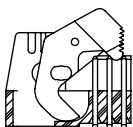
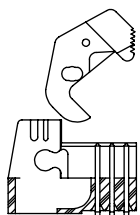

FIG 9
-TR: TAPE & REEL

ARM ASSEMBLY & ROTATION



PROPRIETARY NOTE
THIS DOCUMENT CONTAINS CONFIDENTIAL AND PROPRIETARY INFORMATION AND ALL DESIGN, MANUFACTURING, REPRODUCTION, USE, PATENT RIGHTS AND SALES RIGHTS ARE EXPRESSLY RESERVED BY SAMTEC, INC. THIS DOCUMENT SHALL NOT BE DISCLOSED, IN WHOLE OR PART, TO ANY UNAUTHORIZED PERSON OR ENTITY NOR REPRODUCED, TRANSFERRED OR INCORPORATED IN ANY OTHER PROJECT IN ANY MANNER WITHOUT THE EXPRESS WRITTEN CONSENT OF SAMTEC, INC.

DO NOT SCALE DRAWING

SHEET SCALE: 2:1



520 PARK EAST BLVD, NEW ALBANY, IN 47150
PHONE: 812-944-6733 FAX: 812-948-5047
e-Mail: info@SAMTEC.com code: 55322

DESCRIPTION: .050 EJECTOR HEADER ASSEMBLY

DWG. NO. EHF-1XX-01-X-D-XX-XX-XX-X-XX

BY: ERIC M. 08/17/01 SHEET 3 OF 3